



OWNER'S MANUAL

Better Music Builder is a leader in the Audio and Karaoke equipment industry. We are committed to offering you the high quality audio product. We may update our manual, so we highly recommend you to download the free update from our website www.BetterMusicBuilder.com.

Karaoke Mixing Amplifier

DX-222



Thank you for purchasing this unit. To make full and effective use of this unit, please read this Owner's Manual carefully before operating it. Please retain this manual for future reference.

Passionate about Music

www.BetterMusicBuilder.com

We will not notify you any errors or changes in this manual in advance. If there are any errors and changes in this manual, we will make the corrections in a timely manner. The corrections and changes will be appeared in our website. Therefore, please visit our website www.BetterMusicBuilder.com frequently to find out the most updated information, corrections on errors and changes in this manual. You may also contact us at toll free at 1-800-318-2218.



SAFETY INSTRUCTIONS

1. Read Instructions: All the safety and operation instructions should be read before this product is operated.
2. Retain Instructions: The safety and operating instructions should be kept for future reference.
3. Warnings: All warnings on this product in these operating instructions should be followed.
4. Follow Instructions: All operating and other instructions should be followed carefully.
5. Water and Moisture: This product should not be used near water, for example, near a bathtub, washbowl, kitchen sink, laundry tub, in a wet basement, near a swimming pool, swamp or salivating St. Bernard dog, etc.
6. Cleaning: Clean only with a dry cloth.
7. Ventilation: This product should be situated so that its location or position does not interfere with its proper ventilation. For example, the Component should not be placed on a bed, sofa, rug, or similar surface that may block any ventilation openings, or placed in a built-in installation such as a bookcase or cabinet that may impede the flow of air through ventilation openings.
8. Heat: This product should be stayed away from

heat sources such as radiators, or other devices producing heat.

9. Power Sources: This product should be connected to a power supply only of the type described in these operation instructions or as marked on this product.

10. Power Cord Protection: Power supply cords should be routed so that they are not likely to be walked upon or pinched by items placed upon or against them. Please pay particular attention to cords plugs, convenience receptacles, and the point where they exit this product.

11. Object and Liquid Entry: Care should be taken so that objects do not fall on, or liquids are not spilled into this product.

12. Damage Requiring Service: This product should be serviced only by qualified service personnel when:

- A. The power-supply cord or the plug has been damaged; or
- B. Objects have fallen, or liquid has spilled into this product; or
- C. This product has been exposed to rain; or
- D. This product does not appear to operate normally or exhibits a marked change in performance; or
- E. This product has been dropped, or its chassis has been damaged.

13. Servicing: The user should not attempt to service this product beyond those means described in this operating manual. All other servicing should be referred to the Service Department.

14. To prevent electric shock, do not use this polarized plug with an extension cord, receptacle or other outlet unless the blades can be fully inserted to prevent blade exposure.

15. Grounding or Polarization: Precautions should be taken so that the grounding or polarization means of this product is not defeated.

16. Power Precaution: Unplug this product during lightning storms or when unused for long periods of time. Note that this product is not completely disconnected from the AC power source when the power switch is in the OFF position.

17. This machine does not exceed the Class A/Class B (whichever is applicable) limits for radio noise emissions from digital apparatus as set out in the radio interference regulations of the US Department of Communications.

AC-POWER SOURCES

This set should be operated only from the type of power source indicated on the marking label. If you are not sure of the type of electrical power supplied to your home, consult your dealer or local power company. For those sets designed to operate from battery power, or other sources, refer to the operating instructions.

This unit is designed for use with 120V/60Hz AC. If the area where you live have different power source, you may need to use a transformer to convert to 120 Volts AC.

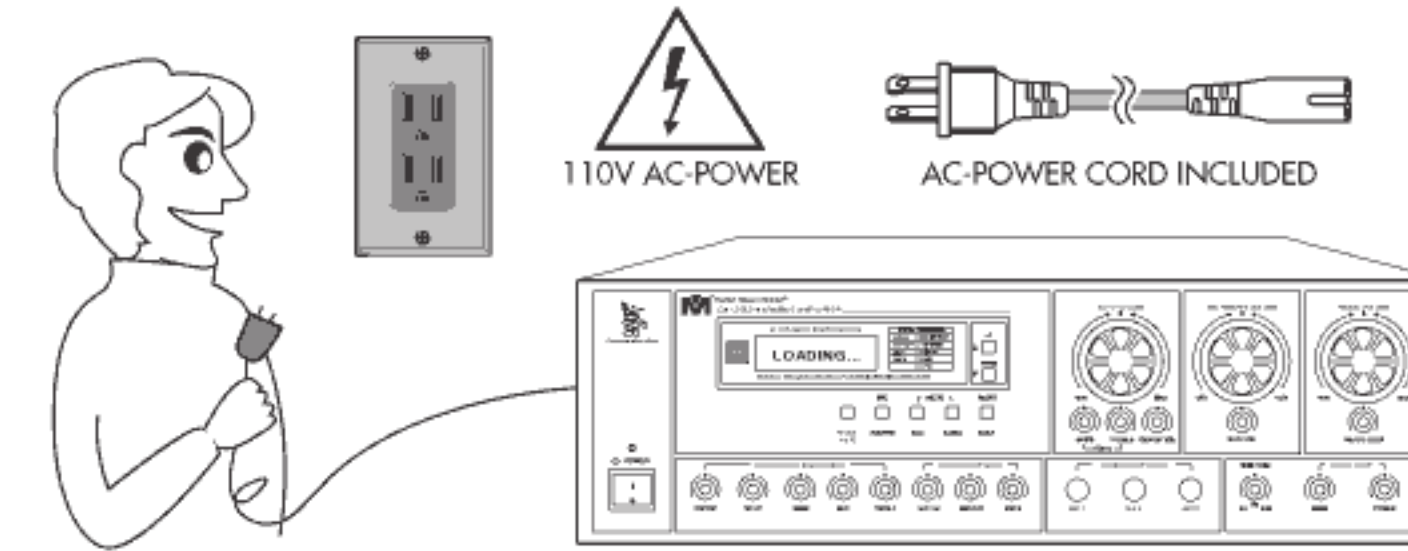

OVERLOADING

Do not overload wall outlets, extension cords or convenience receptacles beyond their capacity, since this can result in fire or electric shock.

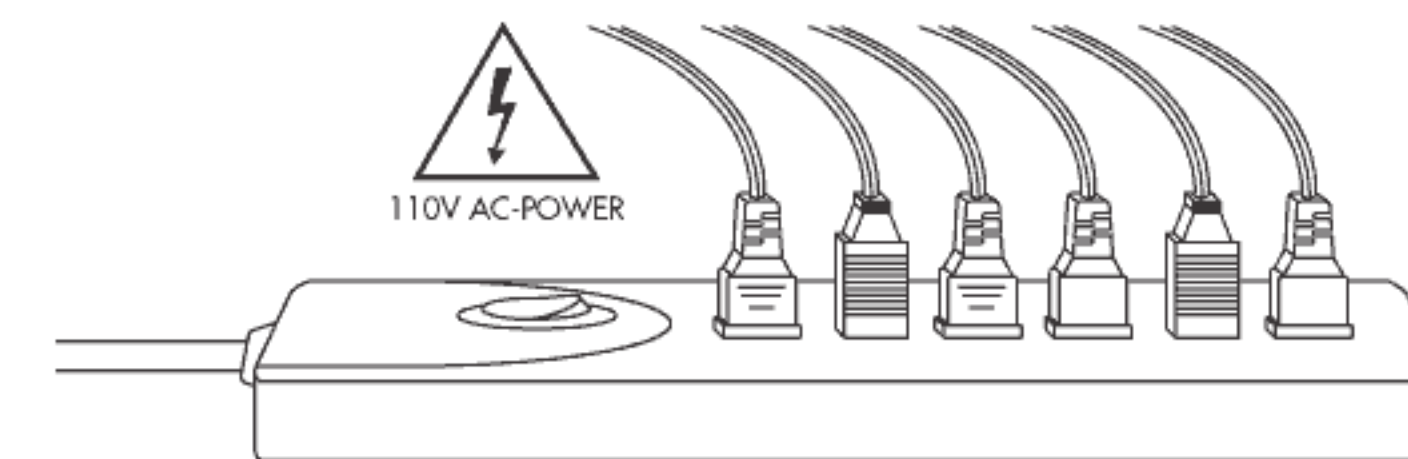

An appliance and cart combination should be moved with care. Quick stops, excessive force and uneven surfaces may cause the appliance and cart combination to overturn.

Do not place the electronic equipment onto the unstable table or stand. It is because it would fall easily from the unstable table or stand, so it may cause accident including personal injuries and damage the equipment. Please follow our instructions to install the equipment, or you may hire a professional technician to handle the installation for safety purpose.

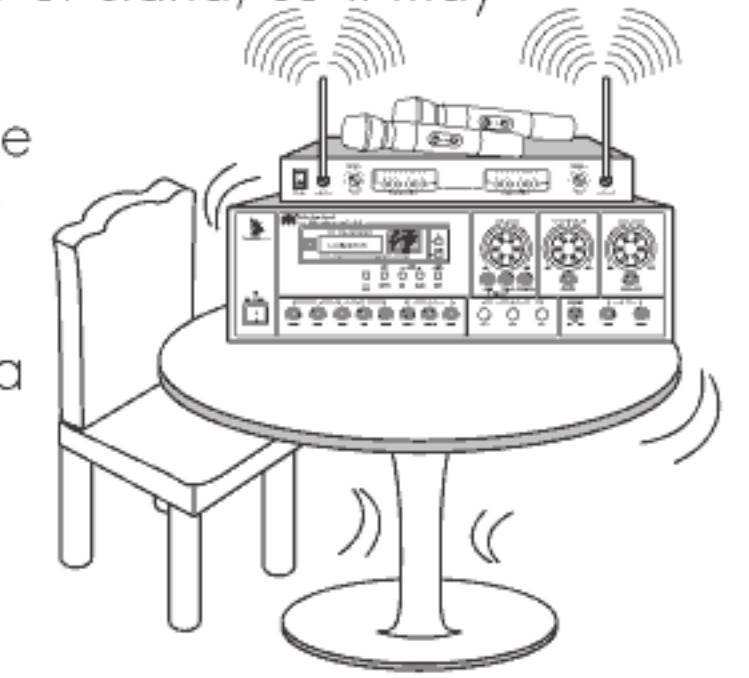

Do not place the set on an unstable cart, stand, tripod, bracket, or table. The set may fall, causing serious injury to a child or an adult, and serious damage to the set. Use only a cart stand tripod, bracket, or table recommended by the manufacturer.

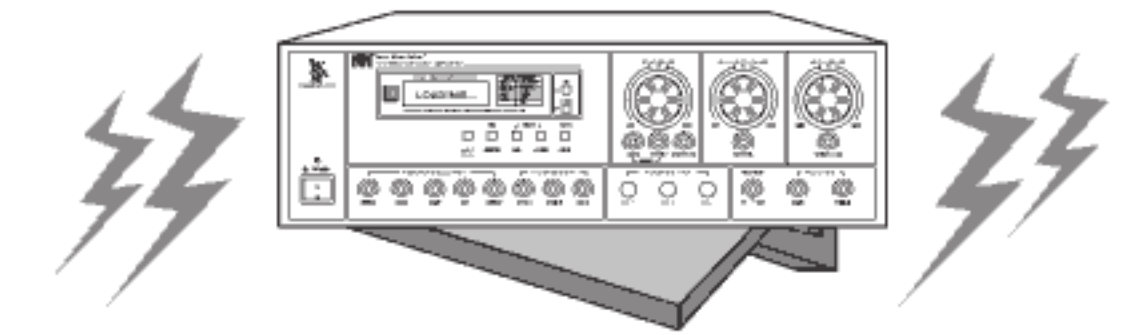

For the set with a three-wire grounding type ac plug: This plug will only fit into a grounding-type power outlet. This is a safety feature. If you are unable to insert the plug into the outlet, contact your electrician to have a suitable outlet installed. Do not defeat the safety purpose of the grounding plug.

Do not store the electronic equipment near water or area with moisture such as bathroom, kitchen sink, laundry area and swimming pool, etc.

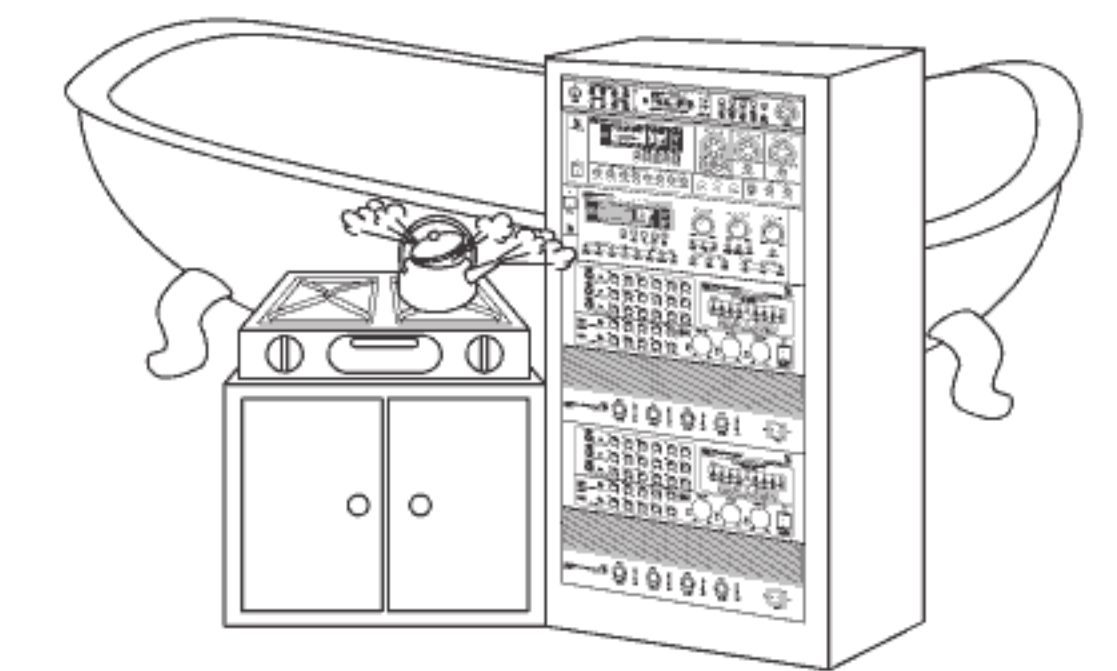

Do not transport the electronic equipment by yourself if its weight exceeds 70 pounds. It is recommended that two people work together to transport the equipment or by using hand truck and the like.

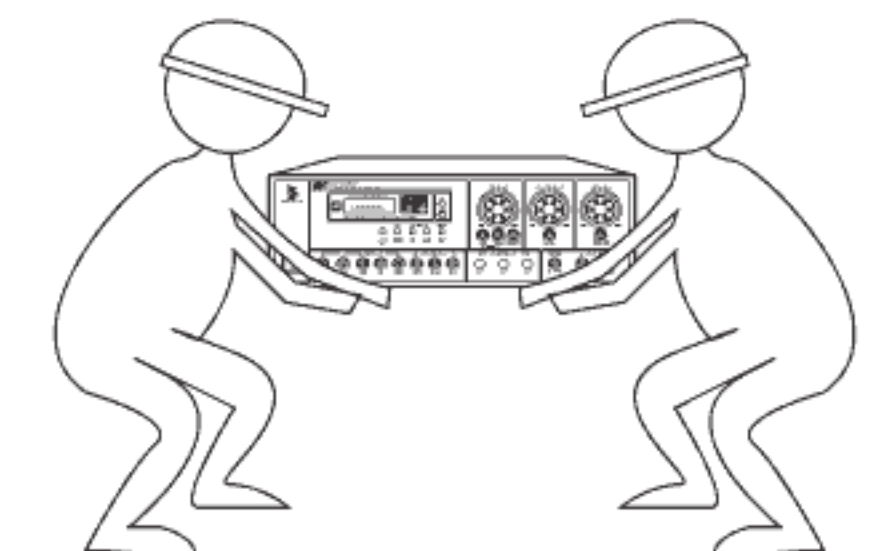

Do not place the electronic equipment directly under sunlight or close to the window. It may cause overheat on the electronic equipment by the sunlight.

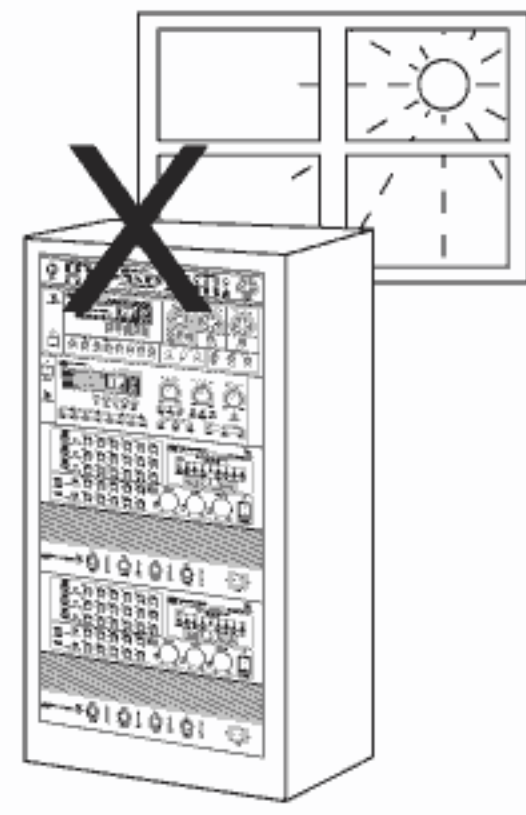

Do not block the openings and vents in the cabinet which is designed for the ventilation of the electronic equipment. The blocking may cause overheat in the electronic equipment because of insufficient circulation of air, so it would damage the electronic equipment.

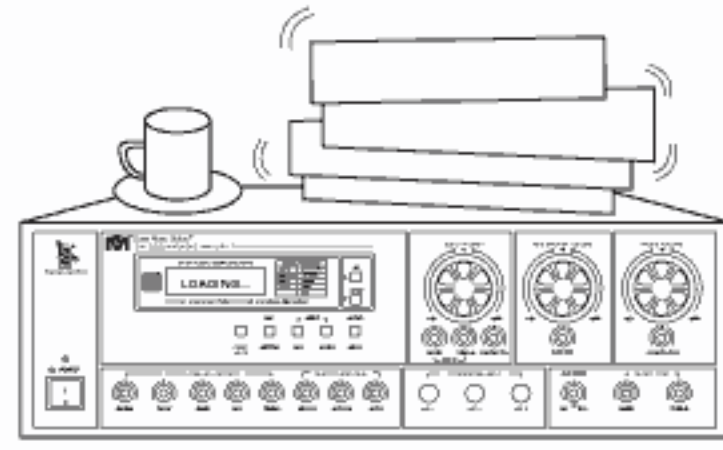

Do not place the electronic equipment near heat sources such as stoves, radiators and heaters, etc. Placing the electronic equipment too near to these heat sources would result in damaging the equipment and causing fire.

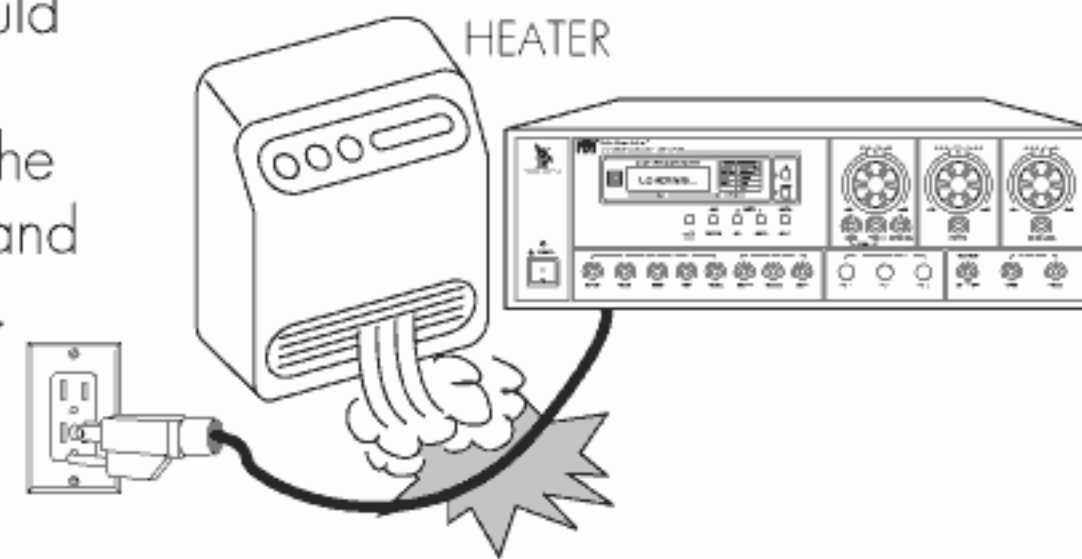

Using the Remote Control Unit

Use the remote control unit by pointing it towards the remote control sensor on the amplifier. Objects between the remote control unit and the remote control sensor may prevent proper operation.

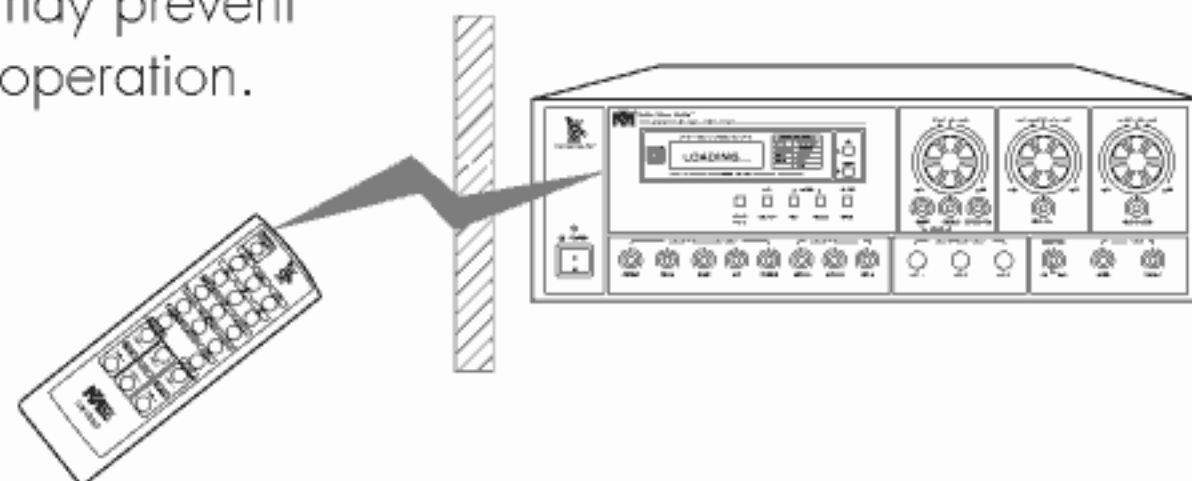

Cautions Regarding the Remote Control Unit

Do not expose the remote control unit to shock. In addition, do not expose the remote control unit to liquids, and do not place in an area with high humidity.



- Do not install or place the remote control unit under direct sunlight. The heat may cause deformation of the remote control unit.
- The remote control unit may not work properly if the remote control sensor on the amplifier is under direct sunlight or strong lighting. In such cases, change the angle of the lighting or the amplifier, or operate the remote control unit closer to the remote control sensor.

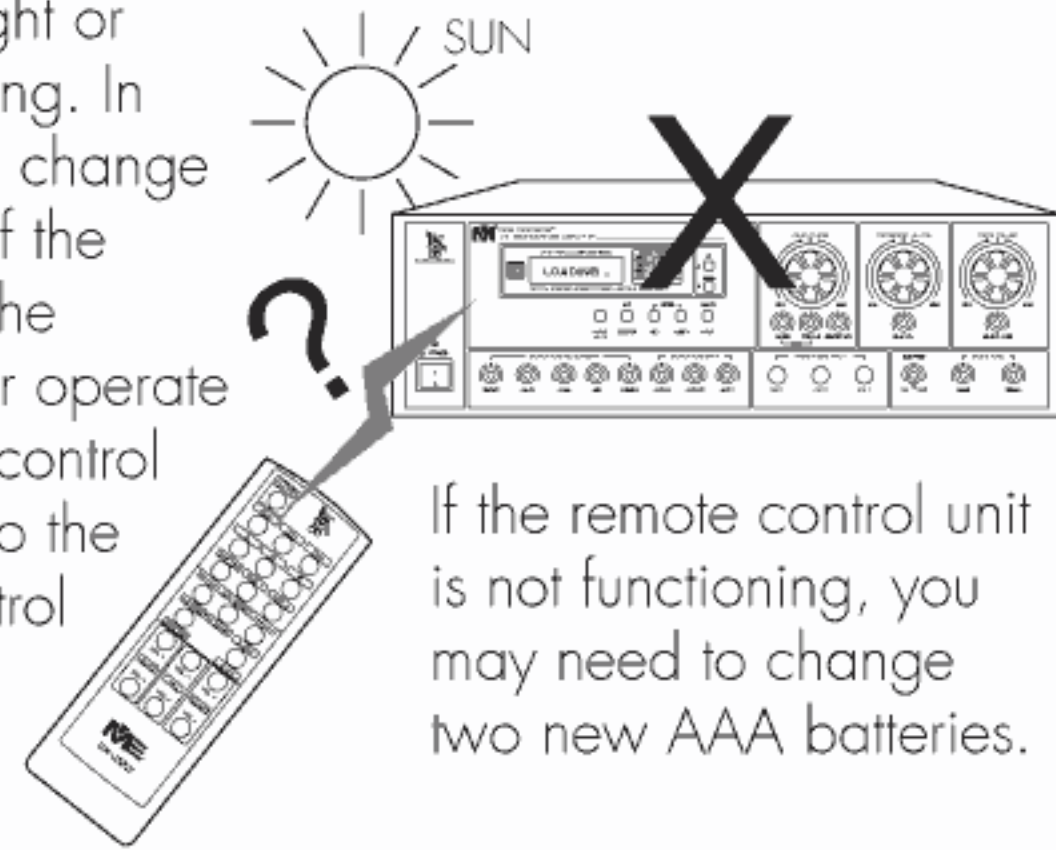

If the remote control unit is not functioning, you may need to change two new AAA batteries.

CONTENTS

Safety instructions.....	2~4
Introduction.....	5
Safety precautions.....	6
Specifications.....	6
Package accessories.....	6
Name and functions of remote control buttons....	7~8
Features and functions of the amplifier.....	9~11
Methods of speaker connection.....	12
Connector information.....	12
How to connect main speaker.....	13
How to connect video monitor.....	13
How to connect music A.V. source.....	14
How to connect recorder & subwoofer.....	14
How to connect High Definition video.....	15
How to connect HDTV.....	16
KTV commercial applications.....	17
Using external channel equipment.....	18~20
How to connect microphone.....	21
Operating instructions.....	22~25
Karaoke room.....	26
Commercial application.....	27
Monitor out.....	28
Ideas for home theater and karaoke.....	29
Pre-out.....	30
Installation setup.....	31
DVD connection for home.....	32
DVD connection for commercial.....	33
Signal flow.....	34
Troubleshooting.....	35
Physical.....	36
Optional for 19" rack mount kit.....	36
Final words to user.....	37
Maintenance.....	38~39

INTRODUCTION

The engineering team of Better Music Builder is a world's leader in designing audio and Karaoke equipment. Karaoke originated from Japan for entertainment. If you have been in the Karaoke nightclub (also called KTV) in Asia, you would be amazed by their advanced Karaoke technology and service. For example, the Karaoke nightclubs in Asia have lots of elegant VIP rooms for their customers. Each VIP room has a big plasma TV and a Karaoke machine with Video-On-Demand (VOD) feature which allows the customers to select songs, pay bills, place food & beverage orders and request room service.

Based on our observations and borrowing the proven design of Karaoke equipment in Asia, Better Music Builder has been constantly improving and developing state-of-the-art Karaoke technologies to satisfy the specific needs of the consumers in North America. Therefore, we have successfully designed both commercial and home entertainment Karaoke equipment for the North America consumers.

Thank you for choosing Better Music Builder DX-222 Karaoke Mixer with DSP (Digital Signal Processing) and built-in feedback destroyer. We appreciate your vote of confidence in this innovative product. Our talented engineering team has many years of experience in audio equipment design. Better Music Builder DX-222 is a new CPU controlled 5-channel Karaoke mixing amplifier.

DX-222 is equipped with the following distinguished features:

- ❖ DSP (Digital Signal Processing) technology customized by Better Music Builder
- ❖ New Five-channel Karaoke power amplifier
- ❖ Three different microphone effects are pre-set by the manufacturer for best sound performance: (1) Stereo effects (2) Echo effects (3) Two effects mixed with fixed echo return times (4) The "FIX" to lock your favorite setting.
- ❖ Mic Exciter enhances the microphone output.

- ❖ High performance 24-bit multi-engine effects processing.
- ❖ Low harmonic distortion.
- ❖ Ultra-wide bandwidth from 2 Hz to 200 kHz for open sound.
- ❖ Center out to monitor the singer's vocal with indeandently adjusted volume.
- ❖ Separate subwoofer output with stereo crossover and independently adjusted volume and cut-off frequency control from 20 Hz ~ 240 Hz.
- ❖ High-performance 24-bit dual-engine Feedback Destroyer.
- ❖ Full computerized feature for source input selection with DVD as the first priority selection. Excellent for Karaoke business.
- ❖ Music modulation with 9-step key control and preset effects for selection.
- ❖ Music volume lock is used to protect speakers.
- ❖ 24 dB/octave, state-variable Linkwitz-Riley filters for precise frequency separation.
- ❖ Absolutely flat summed amplitude response with zero phase difference.
- ❖ Capable of driving two pairs of main speaker in different size to cover the whole frequency spectrum.
- ❖ Independently adjusted AUX input signal volume.
- ❖ Two extra AC power outlets for additional equipment.
- ❖ Music "Mute" allows the microphone to be active while the music is off.
- ❖ Microphone reverb (echo) delay and repeat adjustments.
- ❖ Resetable memory for favorite volume levels.

SAFETY PRECAUTIONS

Selecting fine audio equipment such as the unit you've just purchased is only the first step to your musical enjoyment. Now it's time to consider how you can maximize the fun and the safety of your new equipment. We want you to get the most out of your equipment by playing it at a safe level without affecting your hearing. Sound can be very harmful. Over time your hearing "comfort level" adapts to higher volume of sound. What sounds "normal" can actually be loud and harmful to your hearing. Therefore, please guard against this by setting your equipment at a safe level before your hearing adapts. To establish a safe level, you can start your volume control at a low setting, then slowly increase the sound until you can hear it comfortably and clearly. If used wisely, your new sound equipment will provide you a pleasant experience in music. Since hearing damage from loud noise is often undetectable until it is too late, we recommend you avoid prolonged exposure to excessive noise. The following noises can be dangerous under constant exposure. Therefore, please be cautious with the dB level when playing your new equipment.

Decibel Level	Example
120 dB	Rock band concert in front of speakers, thunderclap
140 dB	Gunshot blast, jet plane
180 dB	Rocket launching pad

SPECIFICATIONS

Power Output.....	500W (250W+250W) Maximum
Music Input (DVD, CDG, AUX)	
S/N Ratio.....	>90dB
THD.....	<0.01%
Input Sensitivity/Impedance.....	0.707v/47kilo ohm
Frequency Response.....	20Hz~20kHz ±2dB
HF (increase/attenuate).....	±10dB
LF (increase/attenuate).....	±10dB
Key Control.....	8 Steps
Super Bass (SUB): THD.....	0.07% 20Hz~15kHz
Mic. Input Section (5 input)	
S/N Ratio.....	>80dB (effect on)
THD (effect off).....	0.04% 50Hz~16kHz
Frequency Response.....	50Hz~20kHz ±3dB
Input Sensitivity/Impedance.....	100mv~500mv/4.7kilo ohm
Microphone Tone	
BASS.....	100Hz±5dB
MID.....	1kHz±5dB
TREBLE.....	10kHz±5dB
Recommended Impedance.....	8 ohm
Standard Power.....	AC 120V/60Hz
Dimensions.....	17"x6"x1.5"/43.2x1.5x38 (cm)
Net Weight.....	28 LBs / 12.7 kg
Shipping Weight.....	32 LBs / 14.5 kg

PACKAGE ACCESSORIES

The Package accessories include a remote control and one AC power cord. All other accessories mentioned in the manual for installation purpose are not included. They are sold separately.

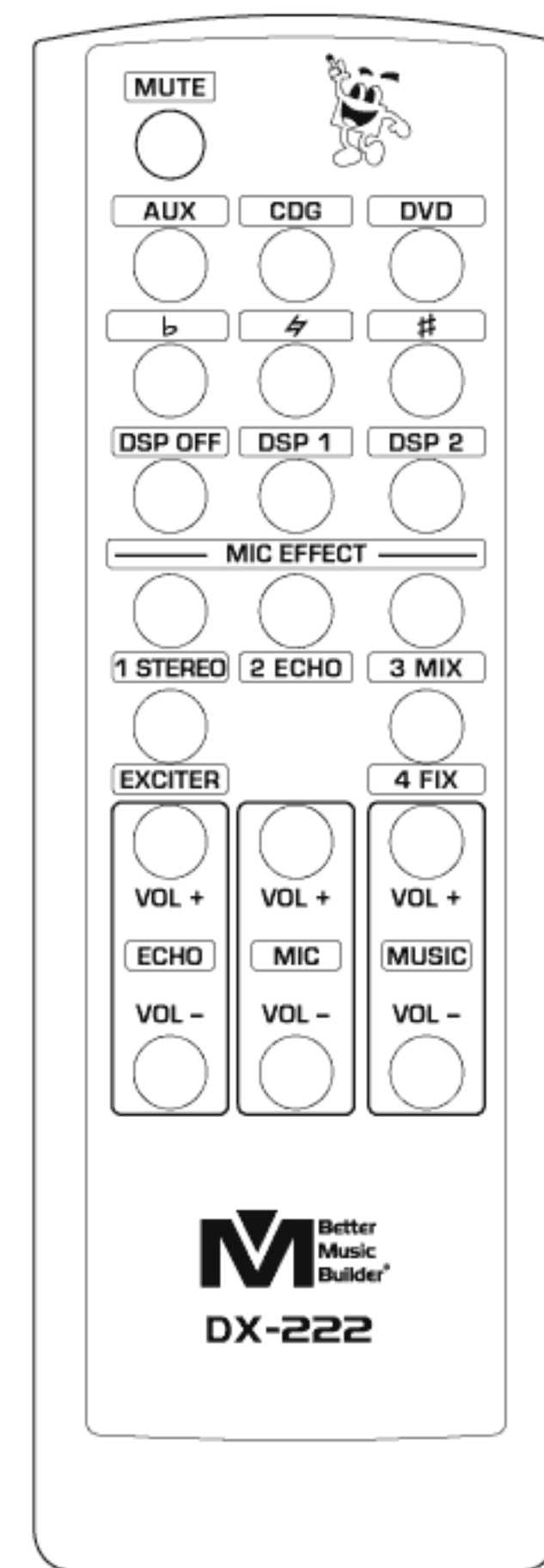

Remote control one unit



Consumer warranty and registration card
<Mail in U.S.A. only>
Consumers from Canada can get the warranty card by downloading it from our website www.BetterMusicBuilder.com.

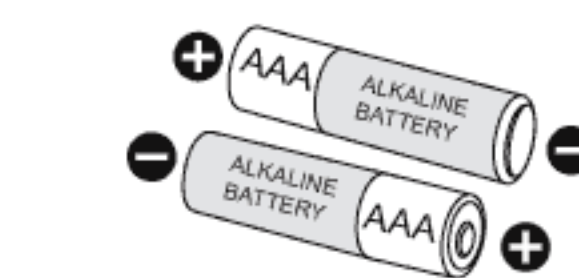

Battery size: AAA (R6 1.5 V)



Plastic Screw Driver
Please use this plastic screw driver

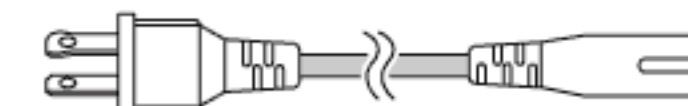

AC power cable (6 feet)
United States (2M) to IEC (F)
(UL) NISPT-2

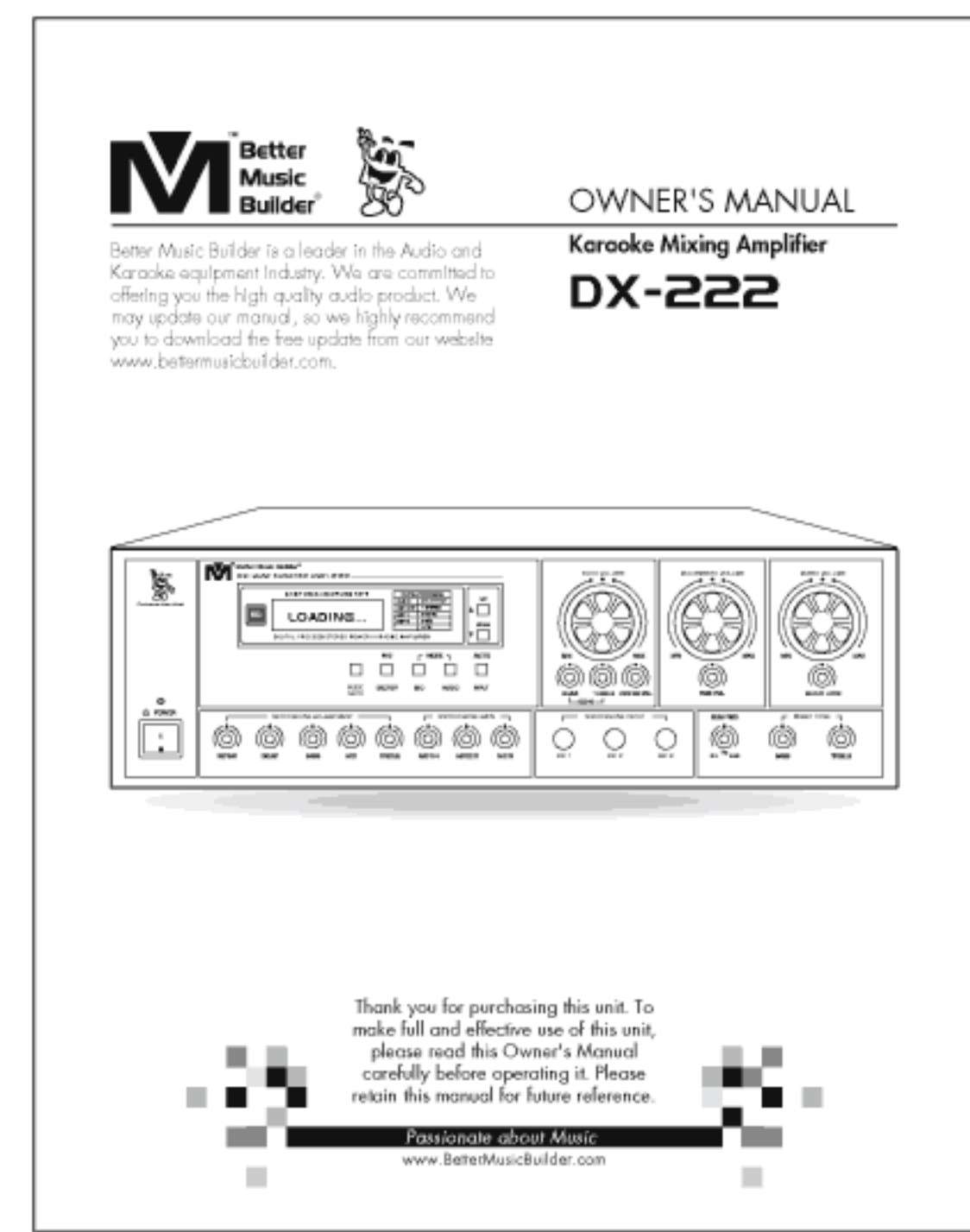

Owner's manual

NAMES AND FUNCTIONS OF REMOTE CONTROL BUTTONS

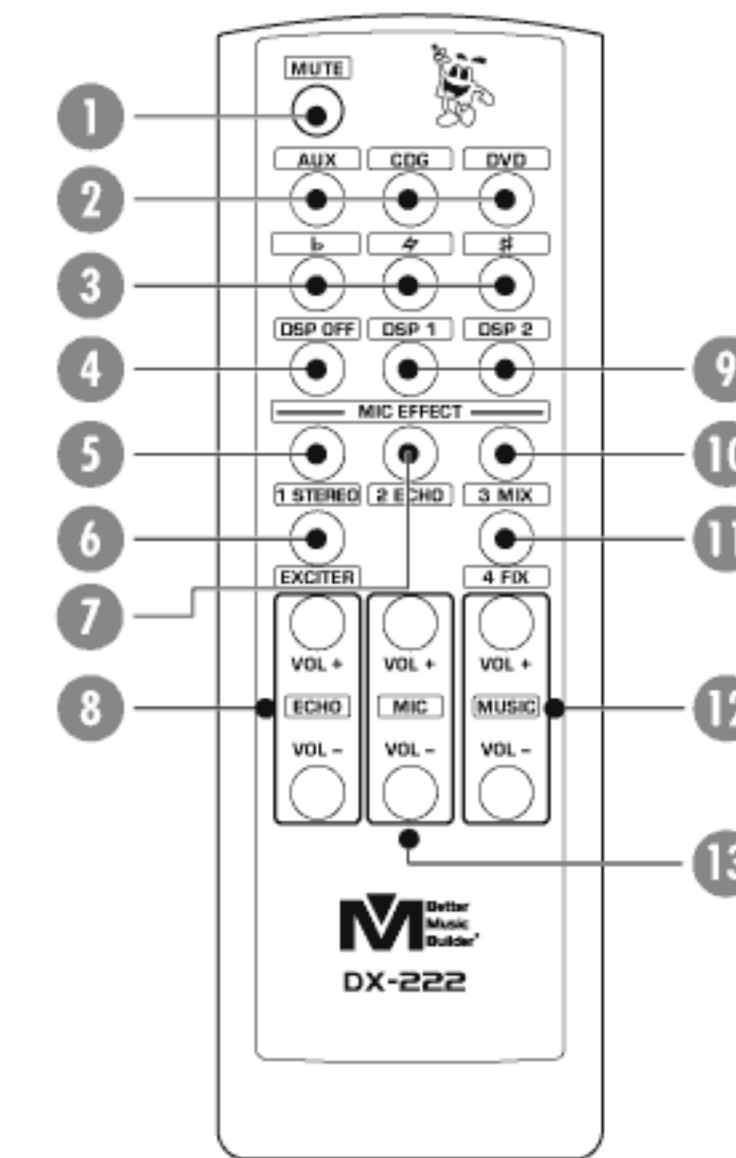

- 1 MUSIC MUTE BUTTON
- 2 INPUT SELECT BUTTON: DVD, CDG, AUX
- 3 KEY CONTROL: **b** LOW, **⚡** NATURAL, **#** HIGH
- 4 MUSIC MODULATOR CONTROL BUTTON
DSP OFF
- 5 1. STEREO KARAOKE EFFECT SELECT
- 6 EXCITER KARAOKE EFFECT SELECT
- 7 2. ECHO KARAOKE EFFECT SELECT
- 8 ECHO VOLUME UP & DOWN BUTTON
- 9 DSP EFFECT 1 & 2
- 10 3. MIXED KARAOKE EFFECT SELECT
- 11 4. FIXED KARAOKE EFFECT SELECT
- 12 MUSIC MASTER VOLUME CONTROL UP & DOWN BUTTON
- 13 MICROPHONE VOLUME UP & DOWN BUTTON
- 14 OPEN BATTERY COVER

Open the battery compartment cover on the back of the remote control unit. The cover should open easily if you press on in with your thumb while sliding it in the direction of the arrow.

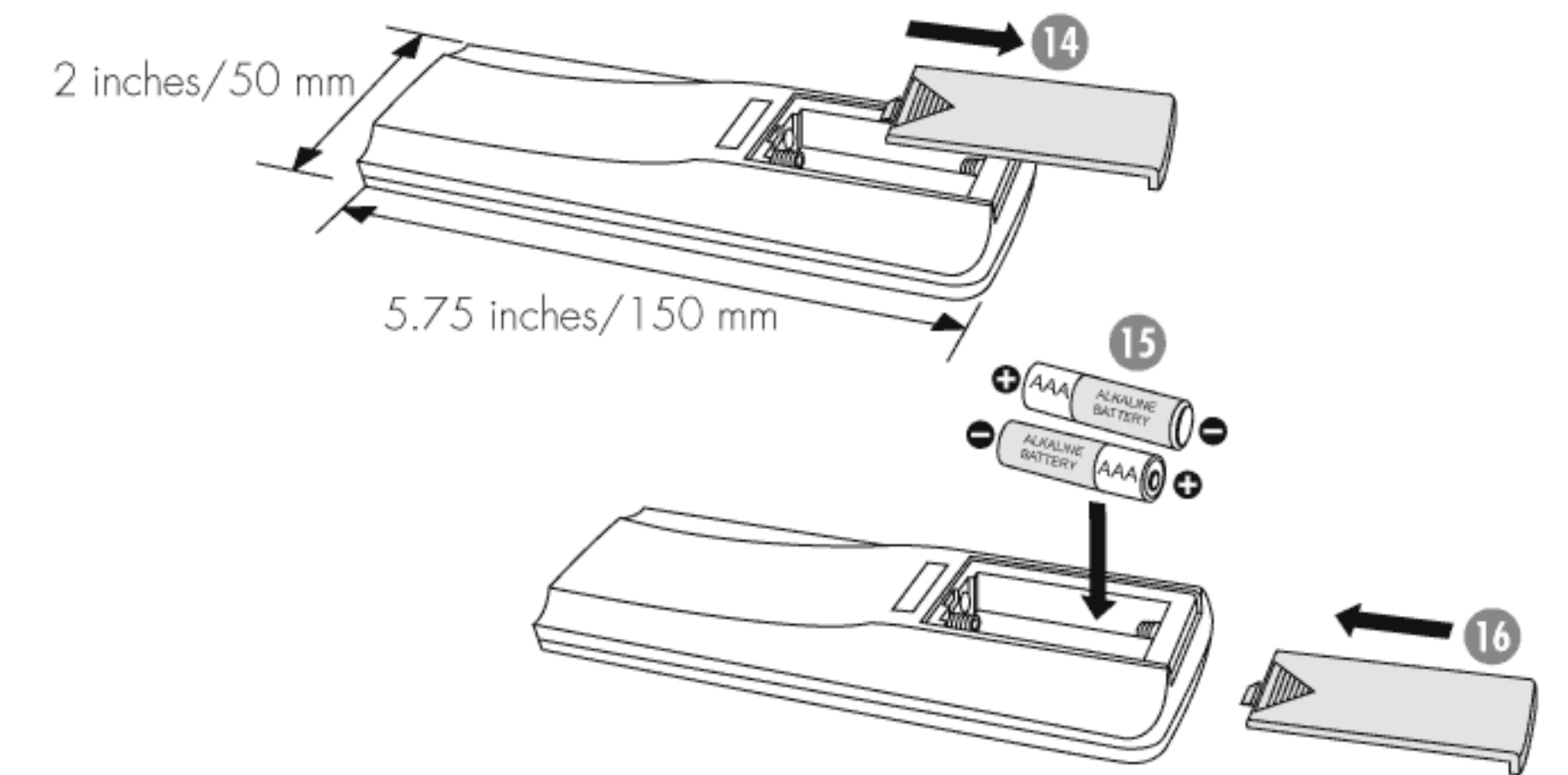

- 15 INSERTING BATTERIES
Insert two size AAA 1.5V (R6) alkaline batteries as shown.

- 16 CLOSE BATTERY COVER
Close the cover of the battery case.

NOTE

Remove the batteries to avoid damage from possible battery leakage whenever you anticipate that the remote control will not be used for an extended period.

Handle the remote control with care. Avoid dropping it, getting it wet, or placing it in direct sunlight, near a heater, or where the humidity is high.

- 17 USING THE REMOTE CONTROL UNIT
When operating the remote control unit, point the unit's infrared signal transmitter at the remote control remote sensor "SR" on the front panel of the AV processor. The remote control unit can be used within a range of about 18 feet (6m) from the remote sensor, and within angles of up to about 30 degrees.

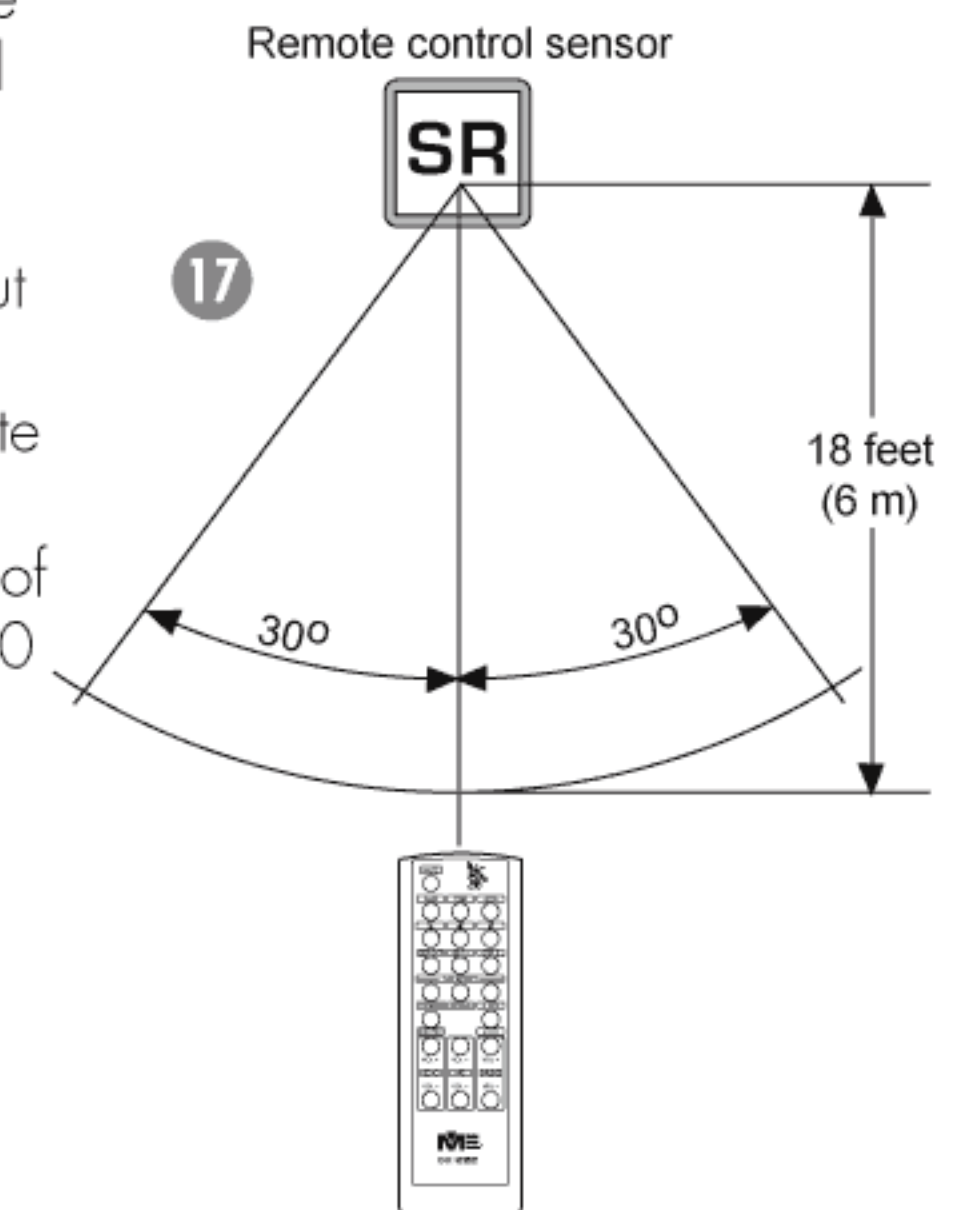

NAMES AND FUNCTIONS OF REMOTE CONTROL BUTTONS

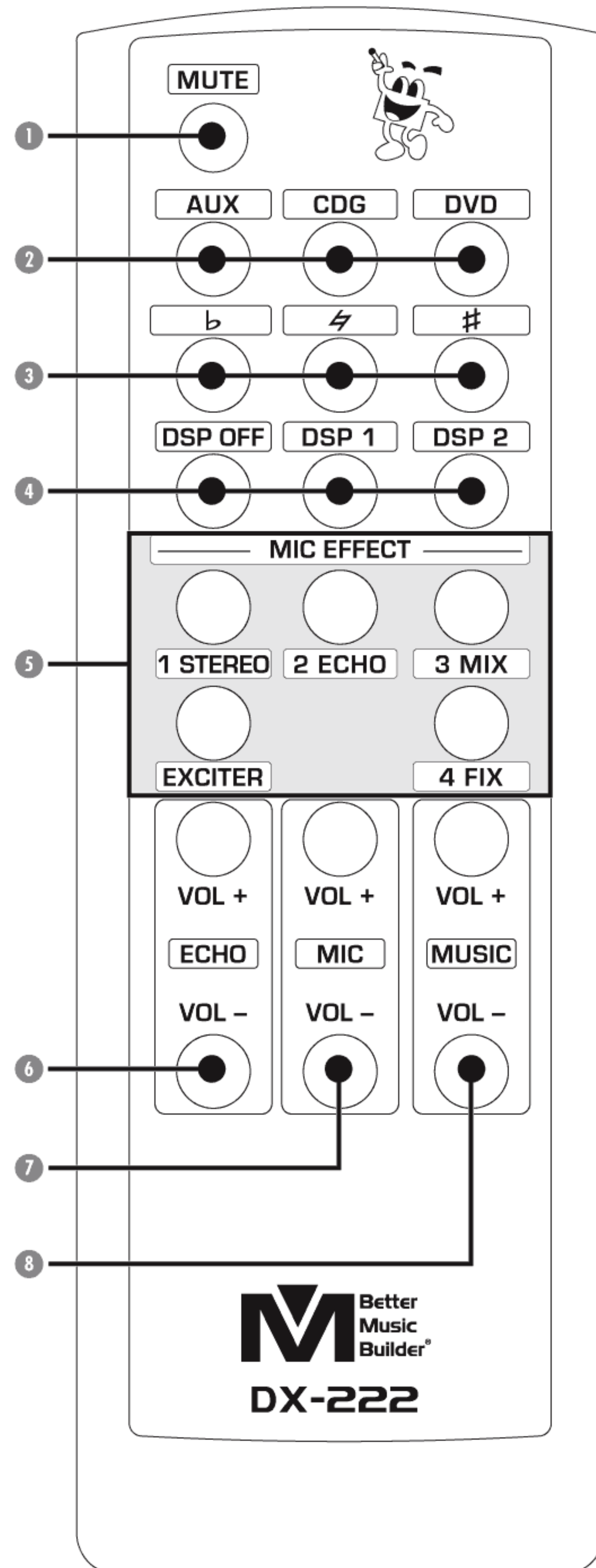

BASIC ADJUSTMENT SETTINGS

- MUSIC MUTE BUTTON**
Music Mute Button is for music only. The microphones are still active.
- INPUT SELECT BUTTON: DVD, CDG, AUX**
When you press this button to select the CDG input, it would not work if DVD is in use. The reason is that this unit is designed with DVD as the first priority input. It is designed for commercial karaoke use. In the KTV karaoke room the select songs must go to the DVD input. If no one selects a song, the DJ control center may switch the line input to play background music (BGM) or to advertise. When someone selects a song, it will automatically switch back to the DVD input.

If you want to use the CDG input, you must turn off the signal connected to the DVD input. If you don't have any equipment connected to the DVD input you can connect the CDG player directly to the DVD input.

- KEY CONTROL: b LOW, ⚡ NATURAL, # HIGH**
Key control button controls the music speed.
 - MUSIC MODULATOR CONTROL BUTTON, DSP EFFECT 1 and DSP EFFECT 2**
DSP stands for Digital Signal Processing. Here "1" effect is to simulate DISCO. DSP "2" effect is to simulate HALL.
 - MIC EFFECT SELECT**
Mic effect 1, 2, and 3 have different vocal effects pre-set by the manufacturer. You have to listen carefully to notice the difference. The "FIX" is to lock the user's favorite vocal effect settings.
- NOTE**
When "FIX" is selected, "ECHO VOLUME," "DELAY," and "REPEAT" are not adjustable.
- ECHO VOLUME UP & DOWN BUTTON**
Range: 00dB to 31dB.
 - MICROPHONE VOLUME UP & DOWN BUTTON**
Range: 00dB to 40dB.
 - MUSIC MASTER VOLUME CONTROL UP & DOWN BUTTON**
Range: 00dB to 90dB.

NAMES AND FUNCTIONS OF FRONT PANEL COMPONENTS

- THIS IS THE WINDOW FOR RECEIVING SIGNAL OF REMOTE CONTROL**
- LCD:** System status display
- MUSIC MUTE BUTTON**
Mutes music only, will not affect microphone output.
- MIC. EXCITER BUTTON**
Mic. will be more sensitive when exciter is on.
- MIC. MODE:** Mic mode program button
- AUDIO MODE:** Music mode program button
- UP CONTROL BUTTON**
- DOWN CONTROL BUTTON**
Use the UP and/or the DOWN button to make your selection when programming the MIC/AUDIO MODE
- AUDIO INPUT SELECTOR**
To select AUX, DVD or CDG
- ECHO BASS:** Adjust the tone of the echo signal.
- ECHO TREBLE ADJUSTING**
Adjusts the tone of the echo signal.
- ECHO VOLUME CONTROL**
To adjust the echo volume for all microphones.
- CENTER VOLUME**
Center output level control.
- SUBWOOFER VOLUME**
NOTE RECORD, SUB and CENTER RCA output jacks are located at the rear.
- MIC. MASTER VOLUME CONTROL**
To control all microphones output level.
- MUSIC LOCK:** Music output level limiter.
- MUSIC VOLUME CONTROL**
To adjust the music output level of speaker group A and group B.

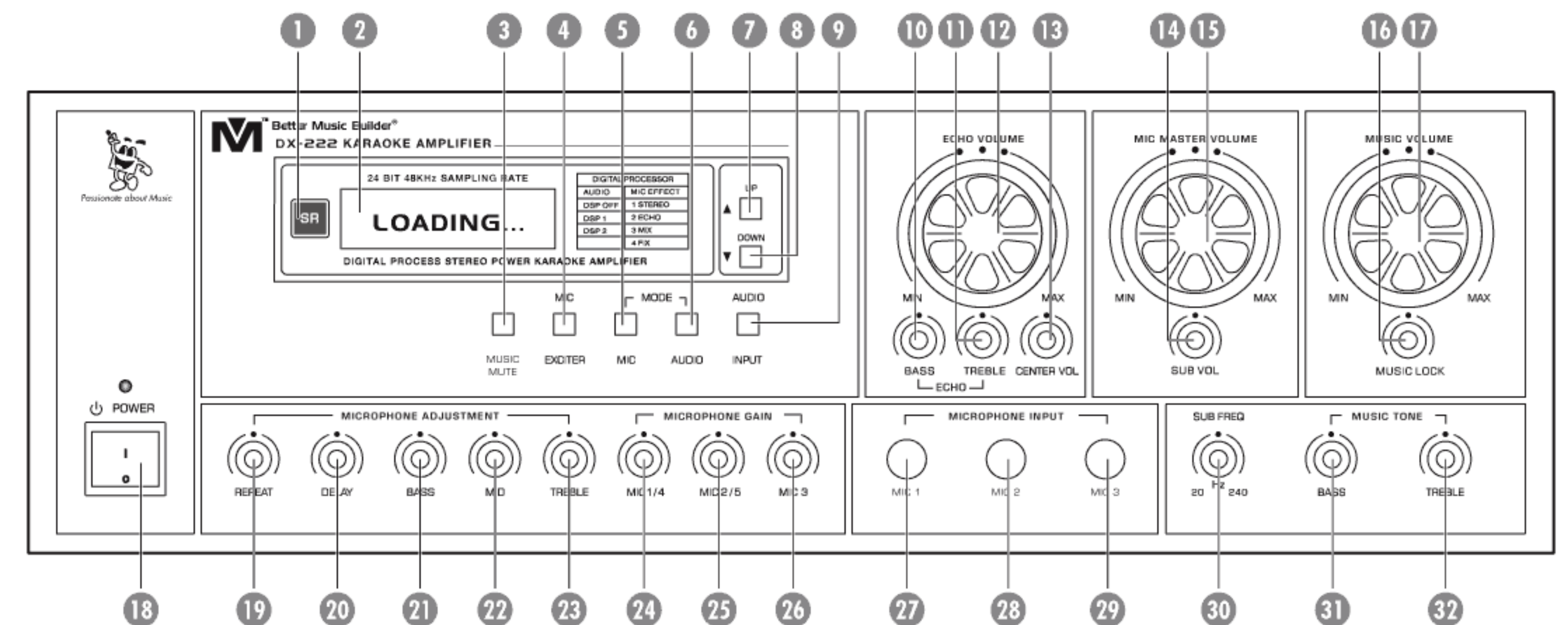

NAMES AND FUNCTIONS OF FRONT PANEL COMPONENTS

- 18 POWER SWITCH**
Press this switch button UP to turn the power ON. Press the switch button DOWN to turn the power OFF (I=ON, O=OFF). Light blue LED is ON when unit is powered.
- 19 REPEAT**
This potentiometer affects the vocal echo effects.
- 20 DELAY**
This potentiometer affects the vocal echo effects.
- 21 BASS (LOW)**
This potentiometer affects the tone of all microphones.
- 22 MID (MIDDLE)**
This potentiometer affects the tone of all microphones.
- 23 TREBLE**
This potentiometer affects the tone of all microphones.
- 24 MIC. (MICROPHONE) 1/4 GAIN**
Microphone 1 is in front panel input and microphone 4 is in rear panel input.
- 25 MIC. (MICROPHONE) 2/5 GAIN**
Microphone 2 is in front panel input and microphone 5 is in rear panel input.
- 26 MIC. (MICROPHONE) 3 GAIN**
- 27 MIC. 1 INPUT 1/4 INCH JACK**
- 28 MIC. 2 INPUT 1/4 INCH JACK**
- 29 MIC. 3 INPUT 1/4 INCH JACK**
MIC 1, 2, and 3 refer to the three front Mic. input jacks and MIC 4 and 5 refer to the two rear Mic. jacks. Adjusting 1/4 will affect both Mic 1 and Mic 4 at the same time. Adjusting the MIC 2/5 pot will affect both Mic 2 and Mic 5 at the same time. The two rear Mic. input jacks can be used for wireless microphone system for a neater appearance.
- 30 SUBWOOFER**
Cut-off frequency potentiometer.
- 31 MUSIC BASS**
Music tone adjustment potentiometer.
- 32 MUSIC TREBLE CONTROL**
Music tone adjustment potentiometer.

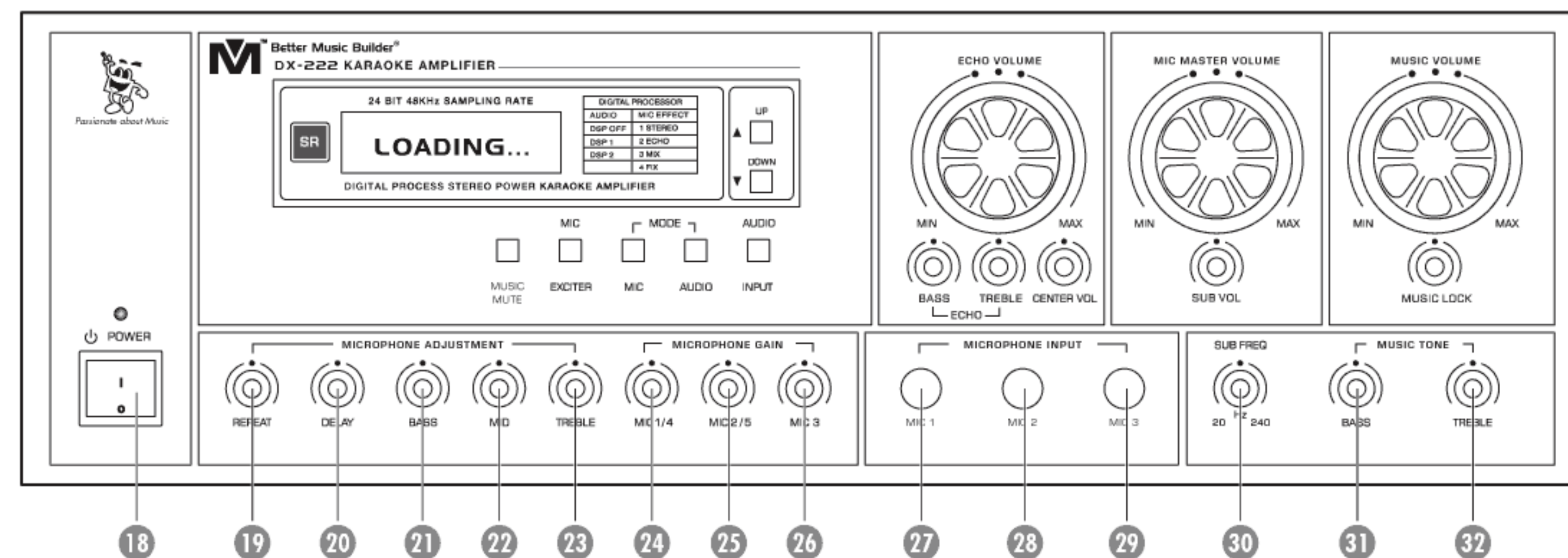

NAMES AND FUNCTIONS OF REAR PANEL COMPONENTS

- 33 AUX VIDEO INPUT TERMINAL**
- 34 CDG VIDEO INPUT TERMINAL**
- 35 DVD VIDEO INPUT TERMINAL**
- 36 VIDEO MONITOR 1, 2 & 3 OUTPUT TERMINALS**
RCA composite video out.
- 37 WIRED REMOTE CONTROL CONNECTOR**
- 38 REAR MICROPHONE 4 & 5 INPUT JACKS**
- 39 SMART FAN**
It automatically turns on when the temperature reaches 60 degrees Fahrenheit. Therefore, if the fan is not on, it does not mean that it does not work.
- 40 120V 60Hz (MAX. 100W) AC-POWER RECEPTACLE**
- 41 FUSE HOLDER**
- 42 AUX INPUT LEVEL ADJUSTMENT**
- 43 AUX AUDIO INPUT TERMINAL: Second priority**
- 44 CDG AUDIO INPUT TERMINAL: Last priority.**
When you use CDG for main input, you must turn off the DVD input signal.
- 45 DVD AUDIO INPUT TERMINAL: First priority**
- 46 RECORD AUDIO OUTPUT TERMINAL: Line level output for connection to an external amplifier.**
- 47 SUBWOOFER AUDIO OUTPUT TERMINAL**
- 48 CENTER AUDIO OUTPUT TERMINAL**
- 49 SPEAKER A (LEFT CHANNEL) OUTPUT TERMINAL**
- 50 SPEAKER B (LEFT CHANNEL) OUTPUT TERMINAL**
- 51 SPEAKER B (RIGHT CHANNEL) OUTPUT TERMINAL**
- 52 SPEAKER A (RIGHT CHANNEL) OUTPUT TERMINAL**
- 53 AC OUTLETS**
This unit is equipped with two UNSWITCHED AC OUTLETS for connecting the power cords of other components to this unit. (Max. 300W) The power to these outlets is not controlled with this unit's POWER switch. They will continuously supply power to any component connected to them.

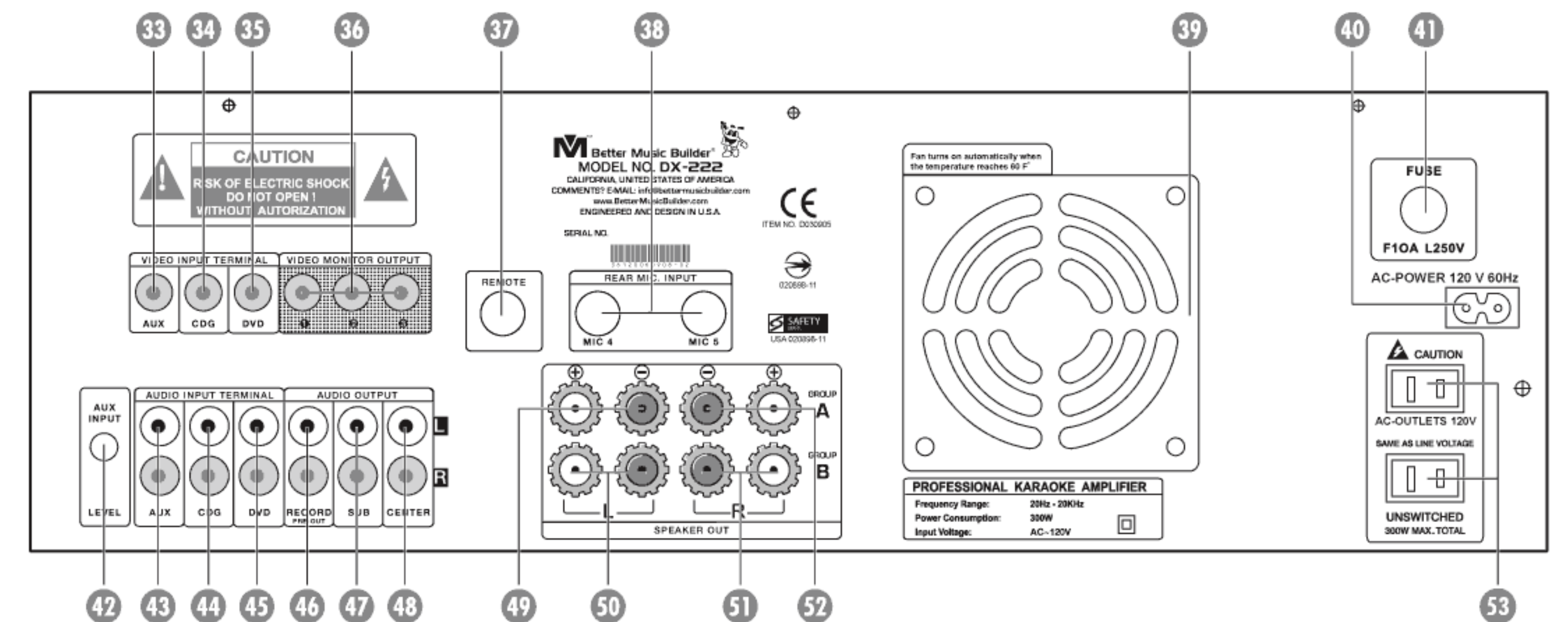

METHODS OF SPEAKER CONNECTION

1. Insert Type

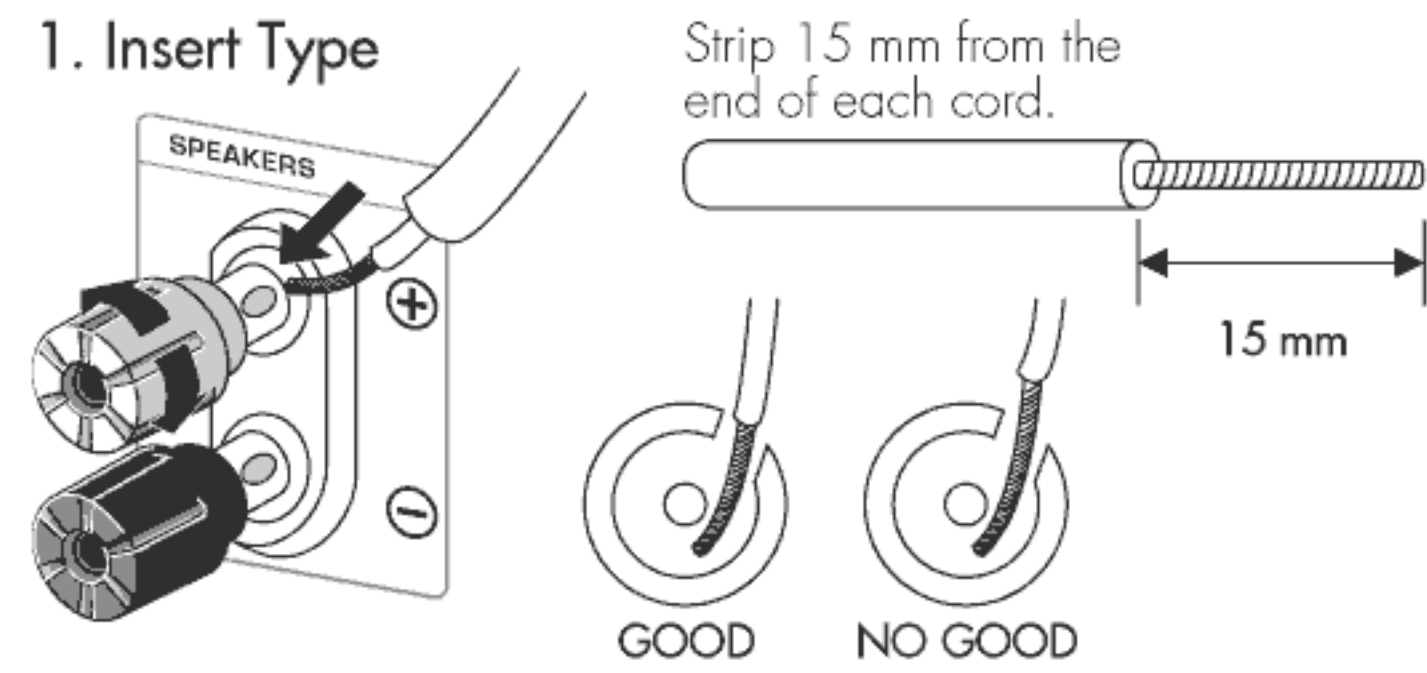

2. Single Banana Plug Type

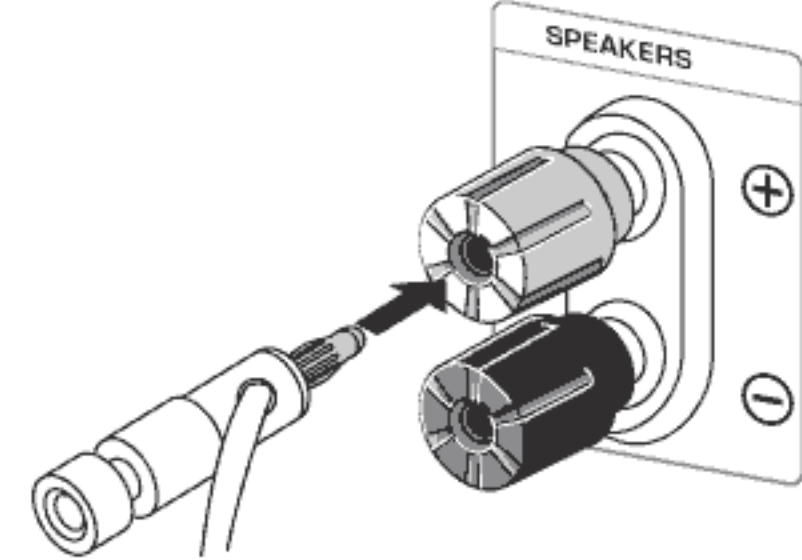

3. Double Banana Plug Type MDP Banana Premium

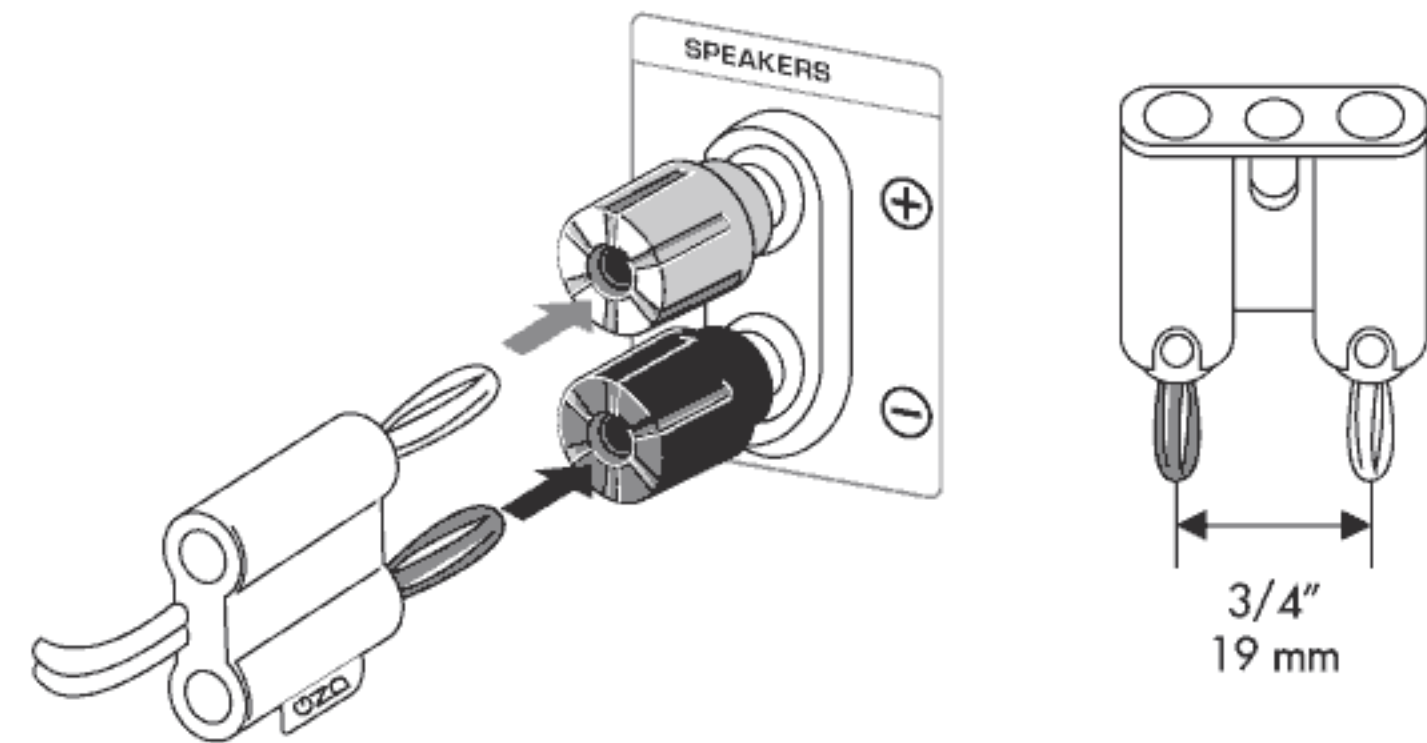

Either banana plug or insert type can be used to connect the unit to speakers. Be sure to connect red (+) to red (+) and black (-) to black (-). Otherwise, the sound output would be 180° out of phase and distorted.

Follow these steps if you are inserting the wire directly into the speaker terminal.

1. Strip off the vinyl covering and twist the tip of the wire core.
2. Loosen the knob and insert the wire core into the terminal hole.
3. Tighten the knob to fix the wire core in place.

Do not allow the wire core to protrude or touch other terminals or wires. If the cores of differing wires touch, damage may result to your components.

CONNECTOR INFORMATION

BALANCED XLR CONNECTORS

	XLR	TRS
Hot (+)	Pin 2	Tip
Cold (-)	Pin 3	Ring
Shield (Ground)	Pin 1	Shield

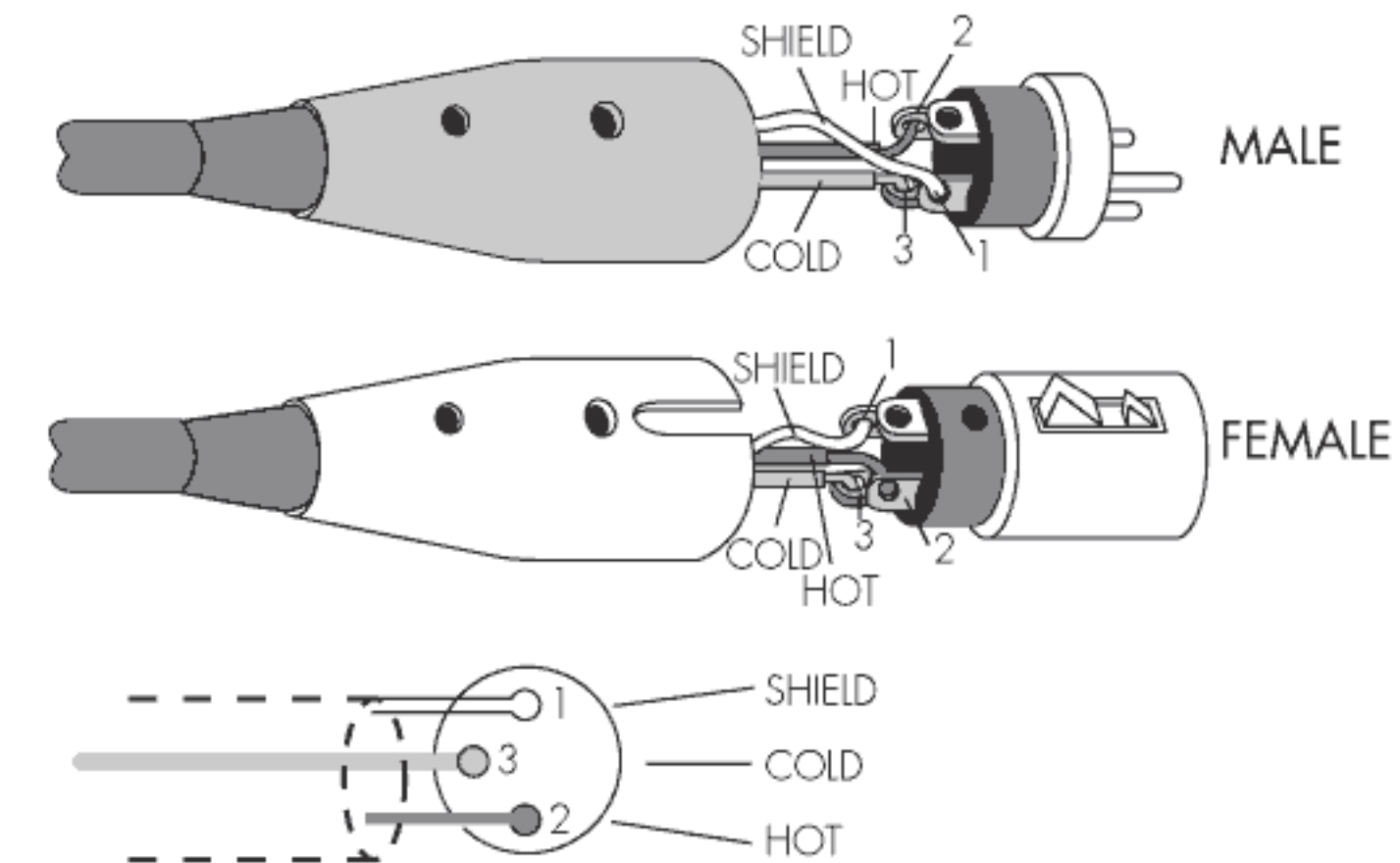

BALANCED 1/4" TRS PLUG

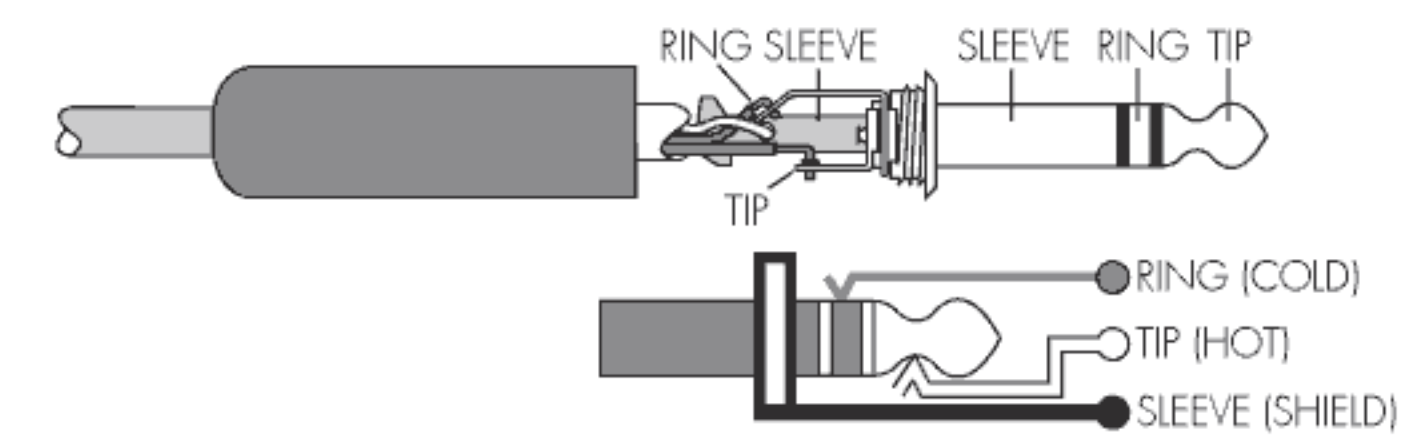

UNBALANCED 1/4" TRS PLUG

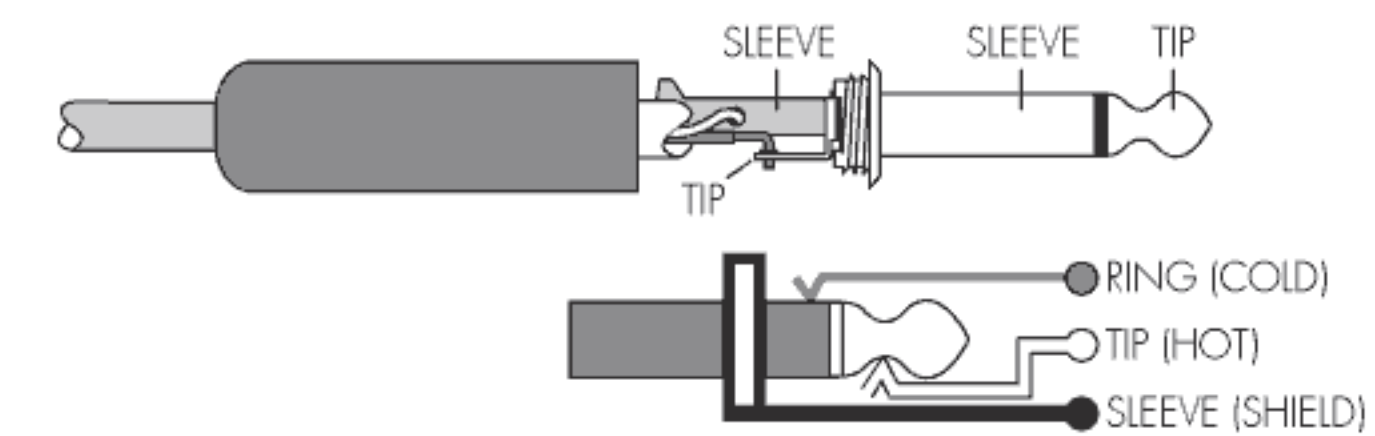

RCA UNBALANCED JACK

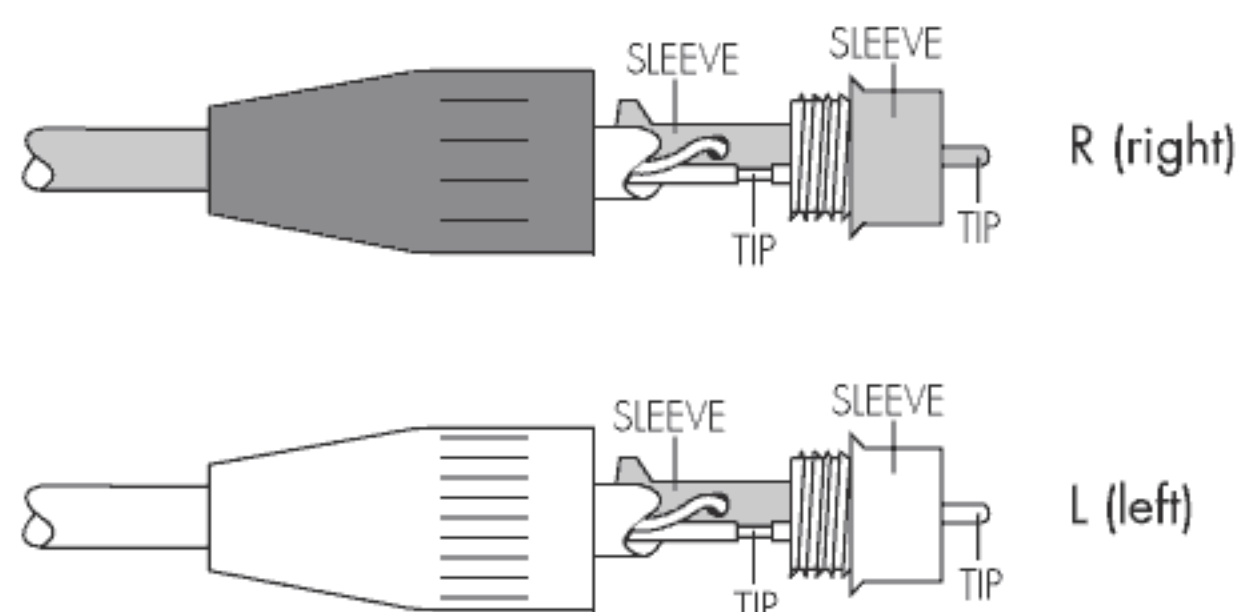

HOW TO CONNECT MAIN SPEAKER

DX-222 is capable of driving four main speakers, which are grouped in Group A and Group B. We recommend you to use different size of speakers for Group A (10-inch woofer or bigger) and Group B (6-inch woofer). Under this arrangement, Group A speaker can produce greater music output while Group B speaker can produce clear vocal. The mixing of music and vocal is important to produce quality sound for singing. Therefore, the audience can feel different effects from Group A and Group B speakers.

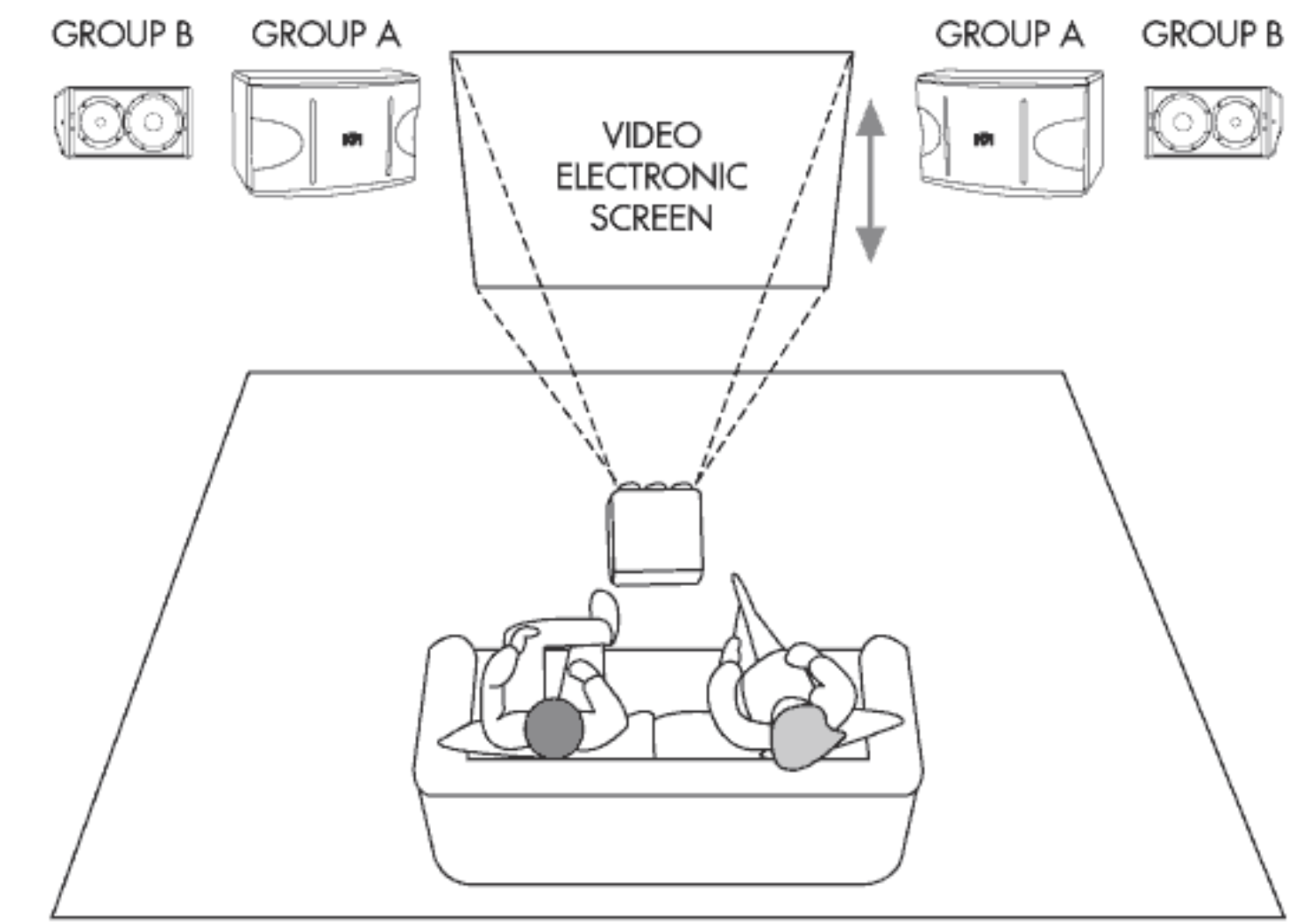
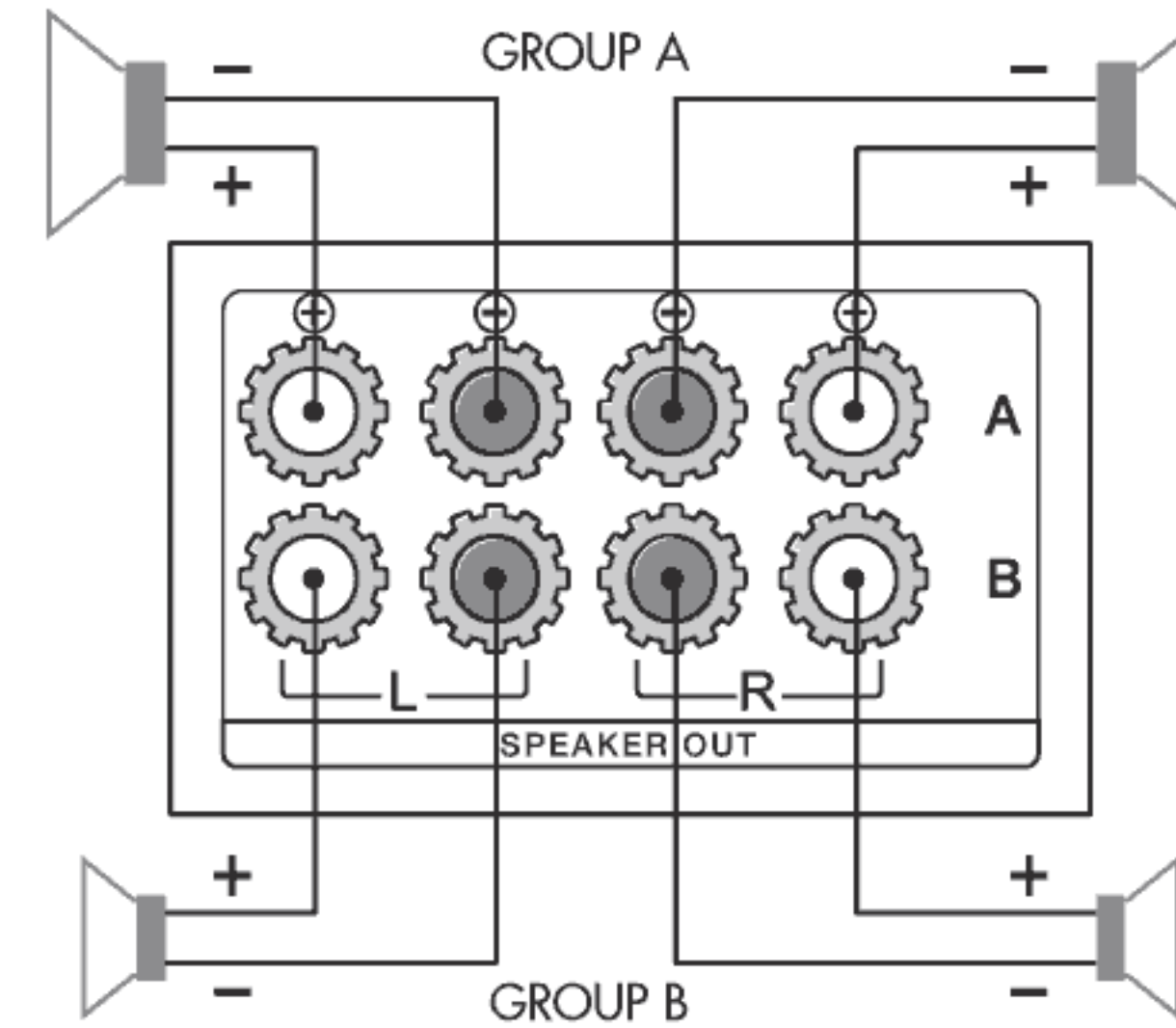

HOW TO CONNECT VIDEO MONITOR

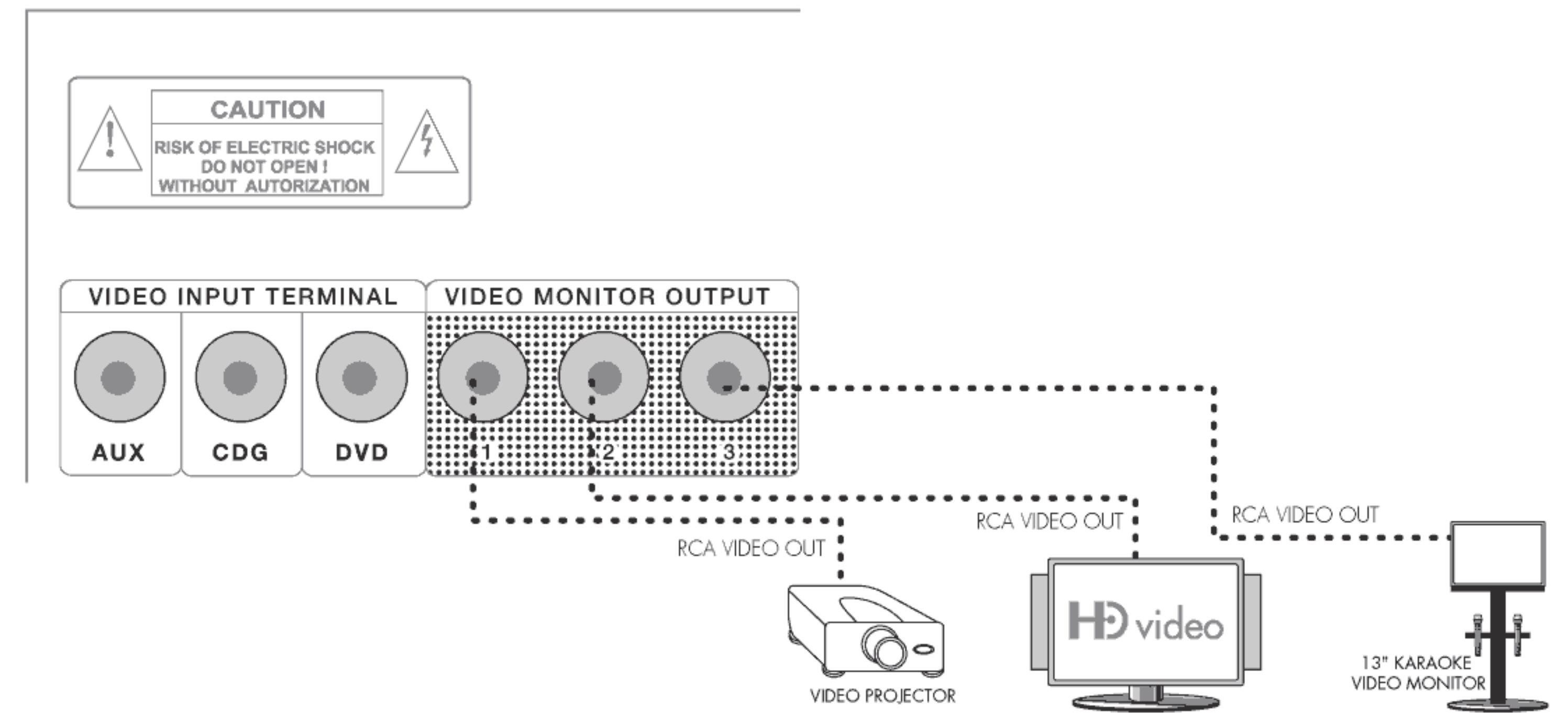

HOW TO CONNECT MUSIC A.V. SOURCE

Before you connect the source (i.e. DVD, CDG and AUX Karaoke), you should turn off the power for all machine, so it would protect you from electric shock and prevent the equipment from damage. To connect the AV source, the first thing to do is to connect the audio source to the amplifier input. Then, you can connect the video source. Please refer to the following diagram. To ensure high quality sound and video, we recommend using high quality cables. To learn more about high quality cable, please refer to page 37.

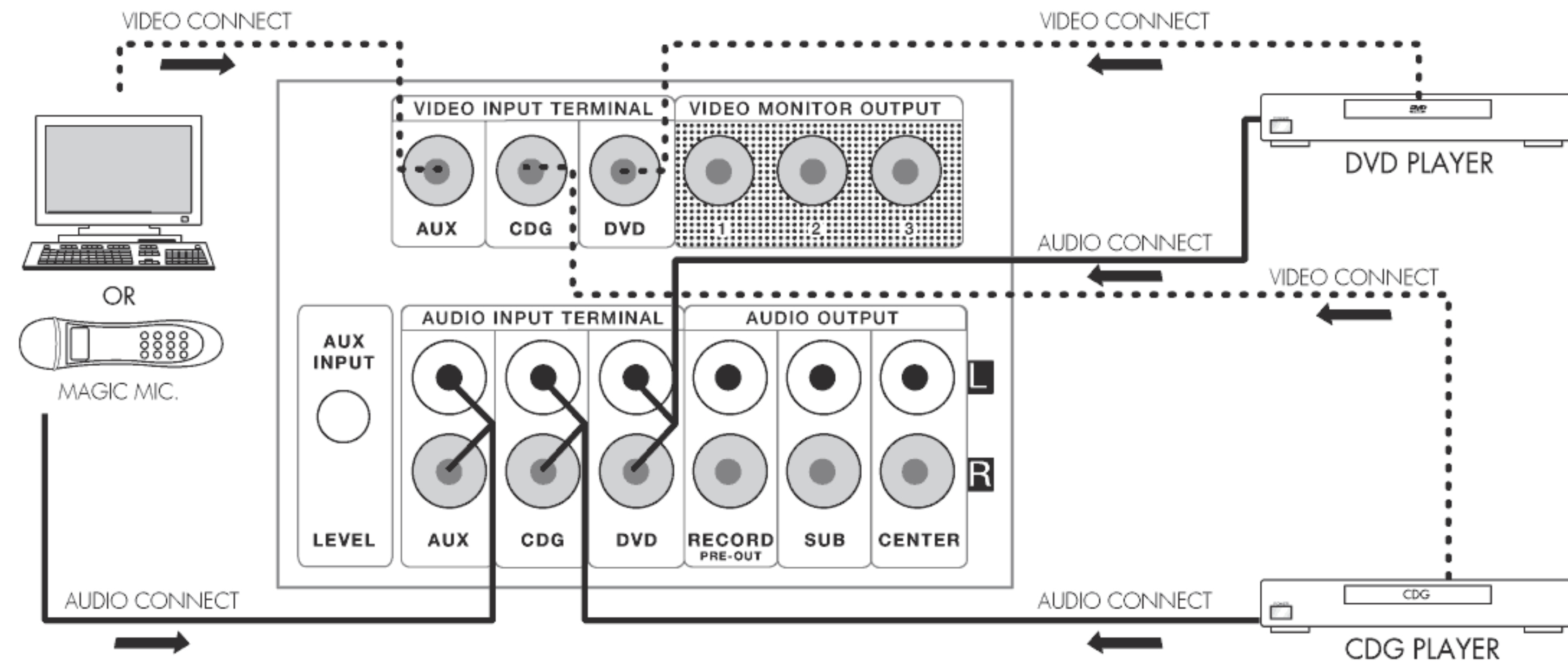

HOW TO CONNECT RECORDER & SUB WOOFER

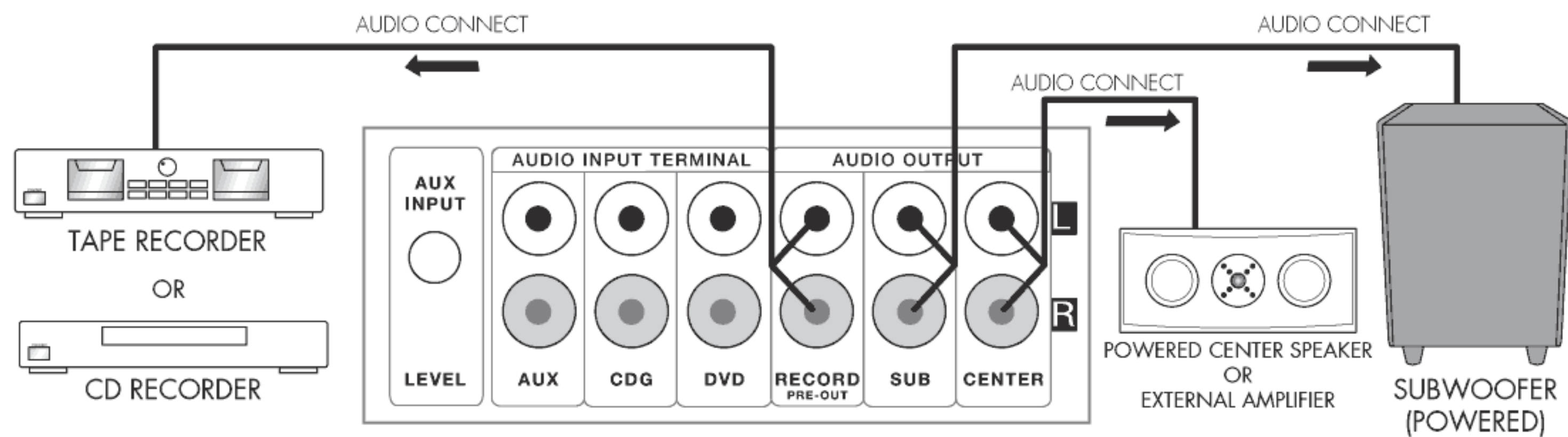

HOW TO CONNECT HIGH DEFINITION VIDEO

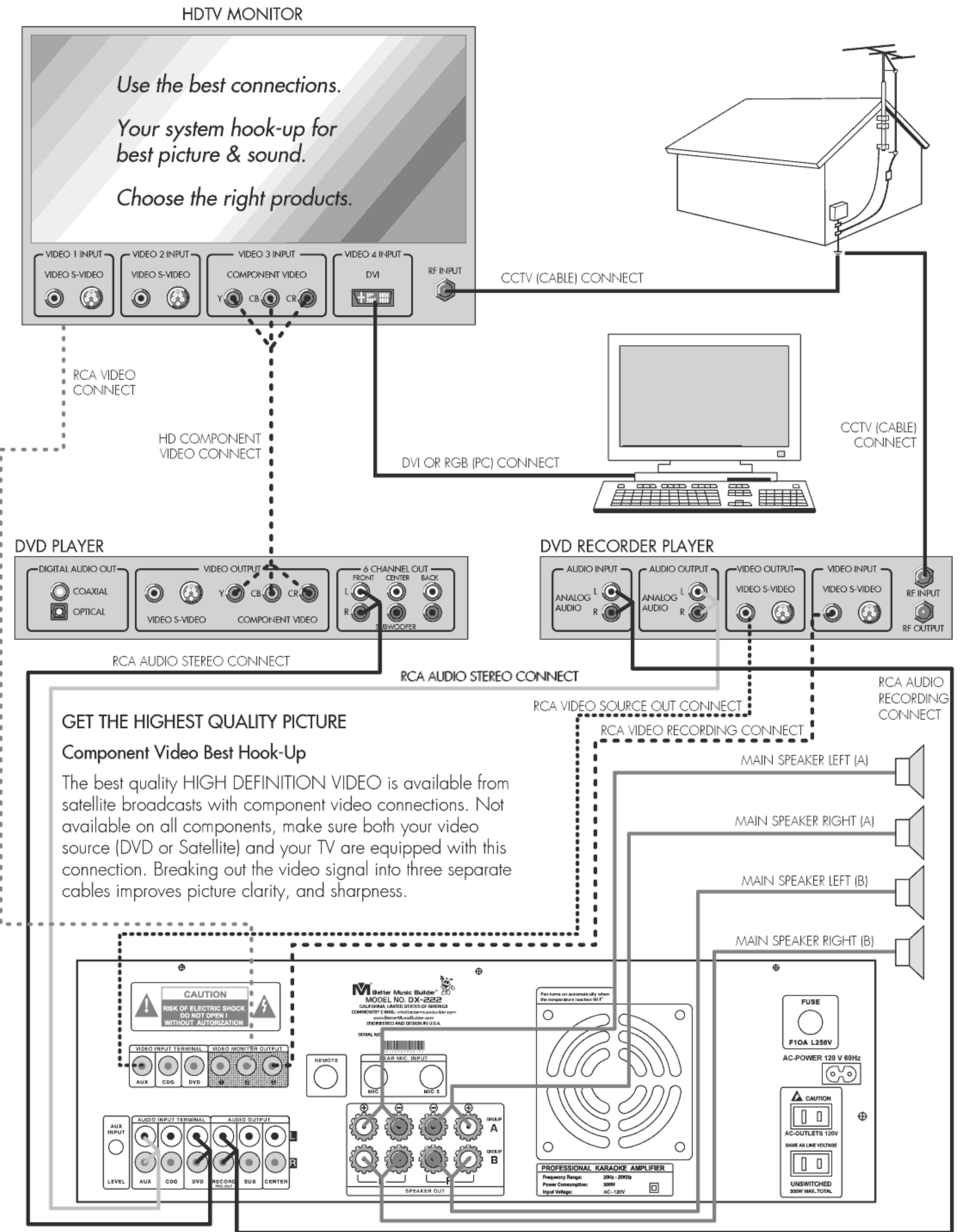

HOW TO CONNECT HDTV

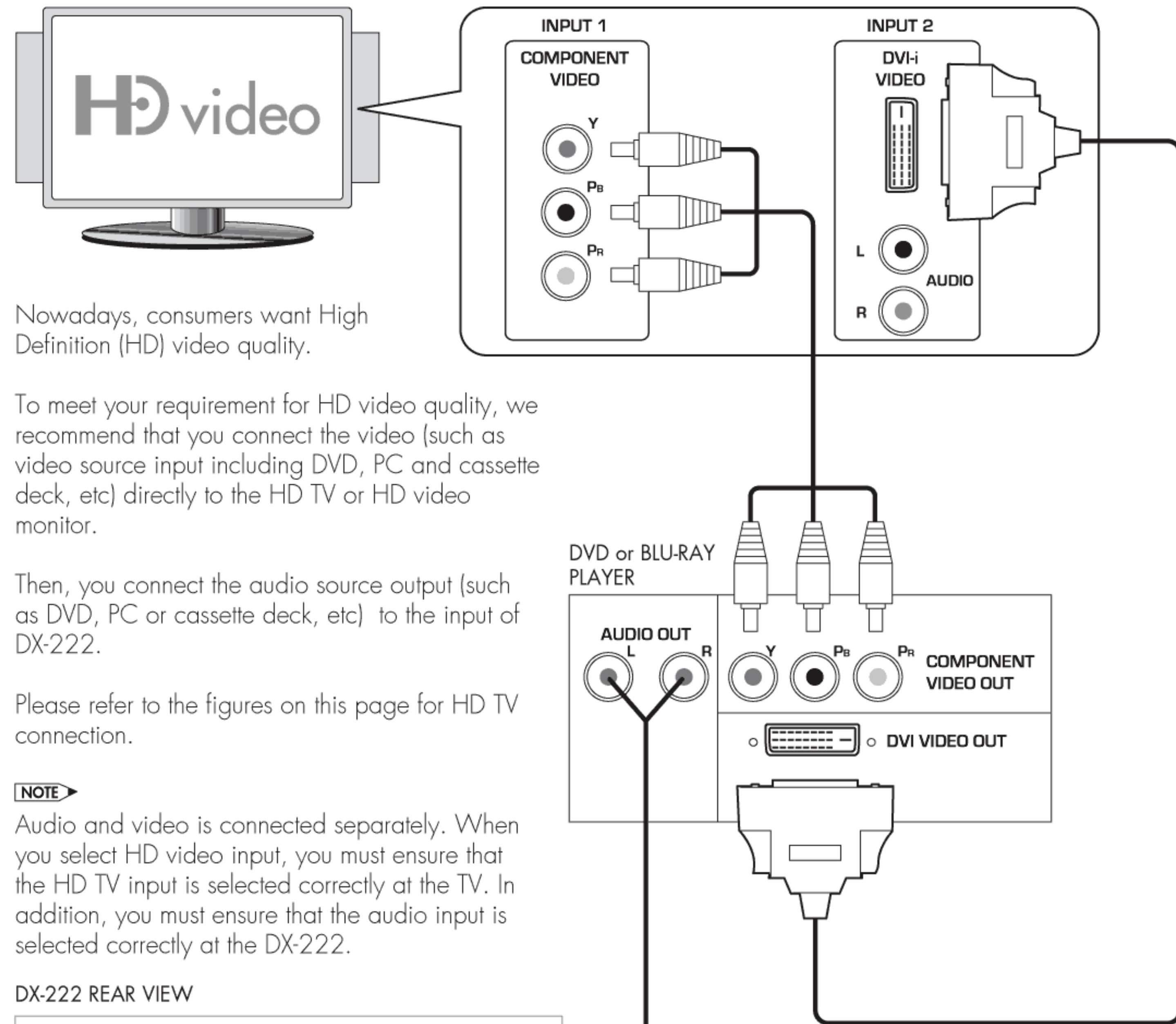

Nowadays, consumers want High Definition (HD) video quality.

To meet your requirement for HD video quality, we recommend that you connect the video (such as video source input including DVD, PC and cassette deck, etc) directly to the HD TV or HD video monitor.

Then, you connect the audio source output (such as DVD, PC or cassette deck, etc) to the input of DX-222.

Please refer to the figures on this page for HD TV connection.

NOTE

Audio and video is connected separately. When you select HD video input, you must ensure that the HD TV input is selected correctly at the TV. In addition, you must ensure that the audio input is selected correctly at the DX-222.

DX-222 REAR VIEW

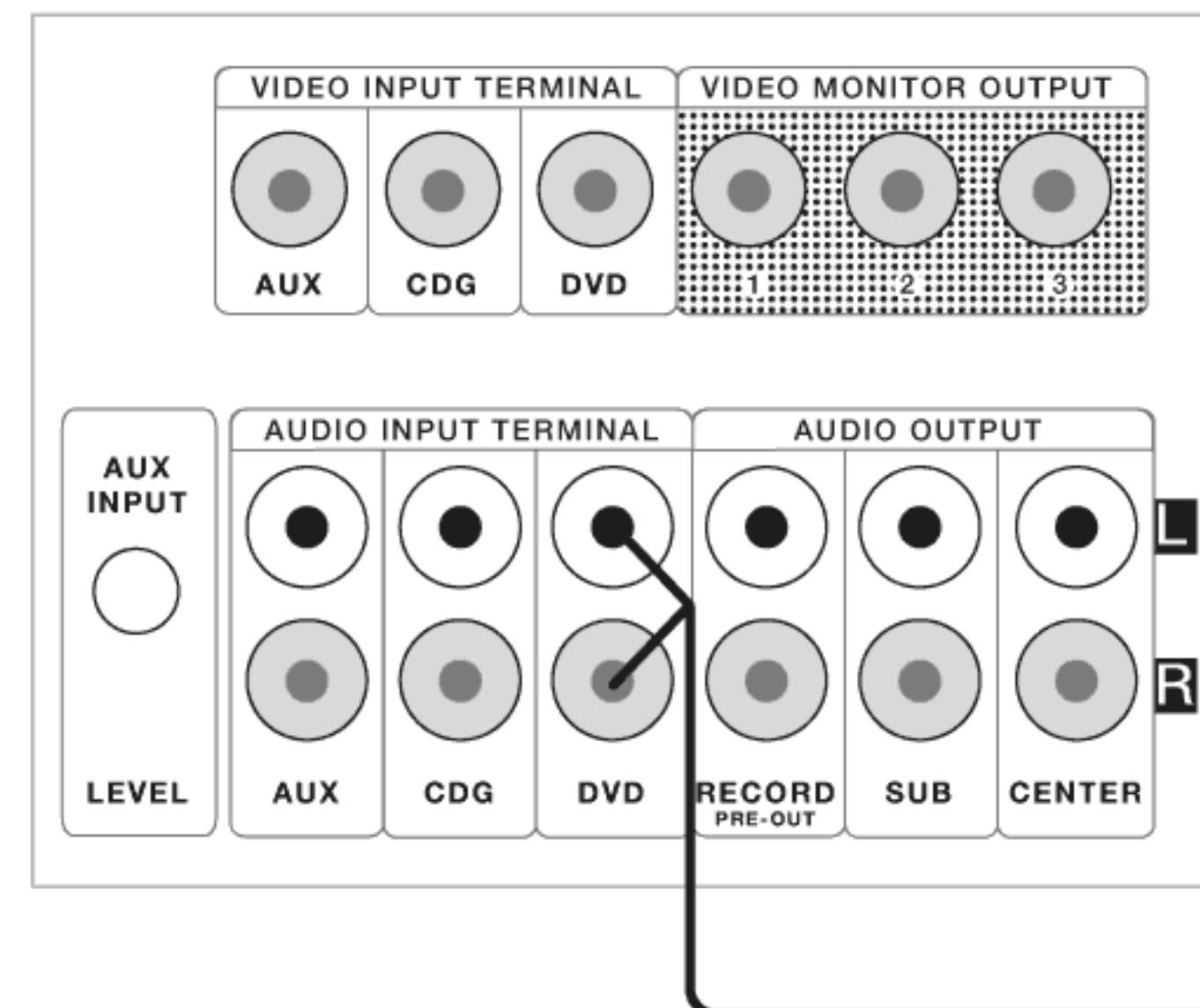

DIGITAL VIDEO

DVI MALE CONNECTOR



DVI FEMALE CONNECTOR

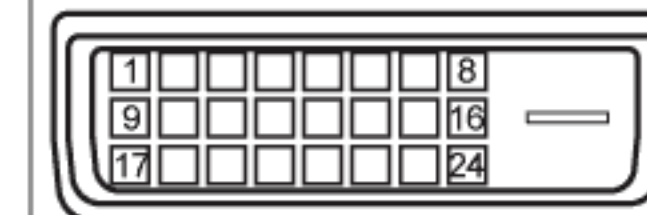

DVI and HDMI connection

Digital Video for high performance, ideal for connecting digital video signal source to digital signal processing distribution and display.

KTV COMMERCIAL APPLICATIONS

Our Better Music Builder engineering team is specialized in KTV equipment design and commercial applications. In KTV audio signal sources (i.e. computer, DVD, VCR and cassette deck) normally come from the DJ room. Each Karaoke room has independent power amplifier and speakers, so it can allow customers to freely make adjustments on music and microphone settings in the Karaoke room. For KTV business application, you need an audio/video distribution amplifier (or simply called AV Distribution amplifier) if the distance between the DJ room and Karaoke room is more than 25 feet to make up for the loss of original signal strength.

A/V Distribution Amplifier is the perfect solution for KTV commercial applications. It is compact, practical and convenient for installation. You can buy this equipment at any audio professional installation company. AV Distribution Amplifier can strengthen the original signals to each Karaoke room from the DJ room. It is also the ideal choice for high-quality and economical 3-channel Analog signal distribution from any HDTV (YPbPr) or RGBHV Video source including 1080p, as well as analog stereo or digital (PCM) Audio.

A/V Distribution Amplifier can deliver crystal-clear, color-rich, artifact-free, and pristine HDTV images to component HDTV-ready monitors in all video formats. It can also drive your HD source to plasma displays, front and rear projectors as well as direct view monitors. In addition, it can be adapted for Composite Video applications. Therefore, you definitely need the AV Distributor Amplifier for KTV commercial use. It would offer your customers excellent sound and video quality for entertainment, so it can enhance the image of your KTV and increase the business.

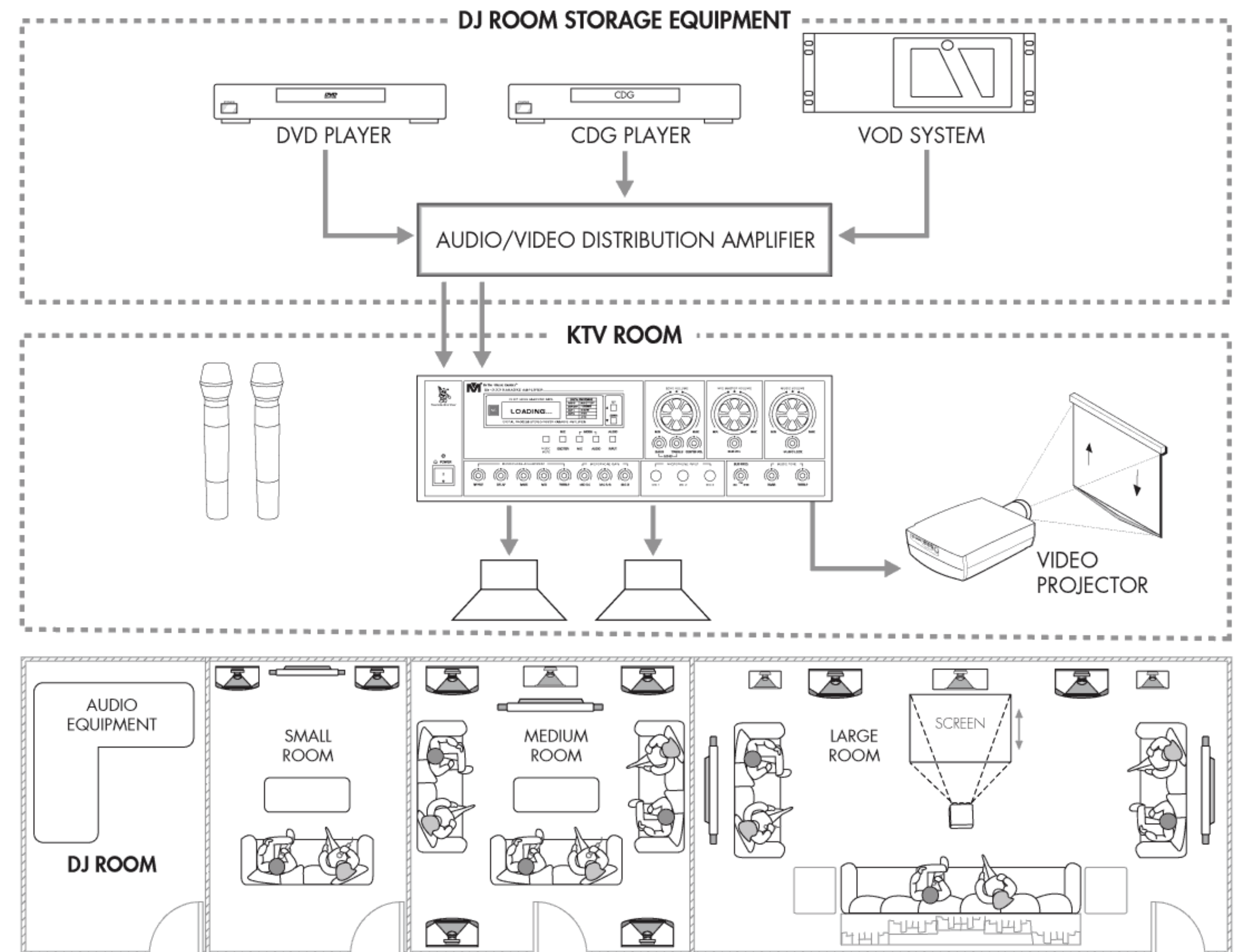

USING EXTERNAL CHANNEL EQUIPMENT

DX-222 is not only a Karaoke mixing amplifier, but it is also a pre-amplifier specially designed for using external equipment. When you connect other equipment to the mixing amplifier, you may need a different type of cable such as RCA to XLR cable. We highly recommend you using high quality cable for connection, so it can give you the crystal clear sound and sharp video image. Please refer to the following figures.

RCA TO RCA CABLE

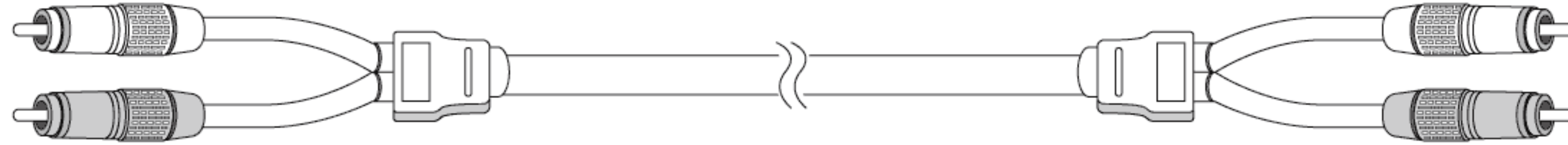

RCA TO XLR CABLE

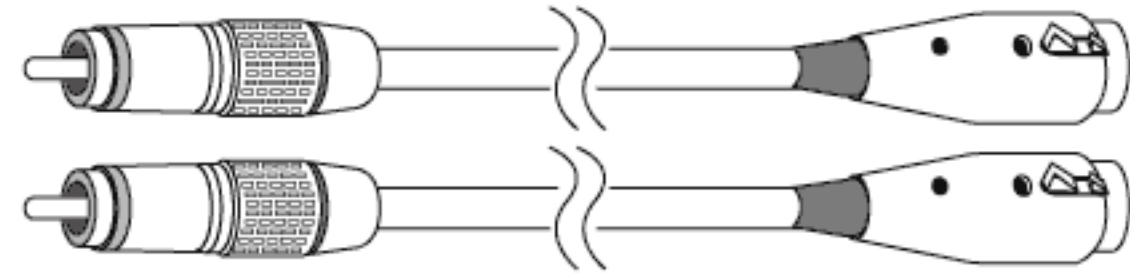

RCA TO MINI CABLE (3.5mm Jack)

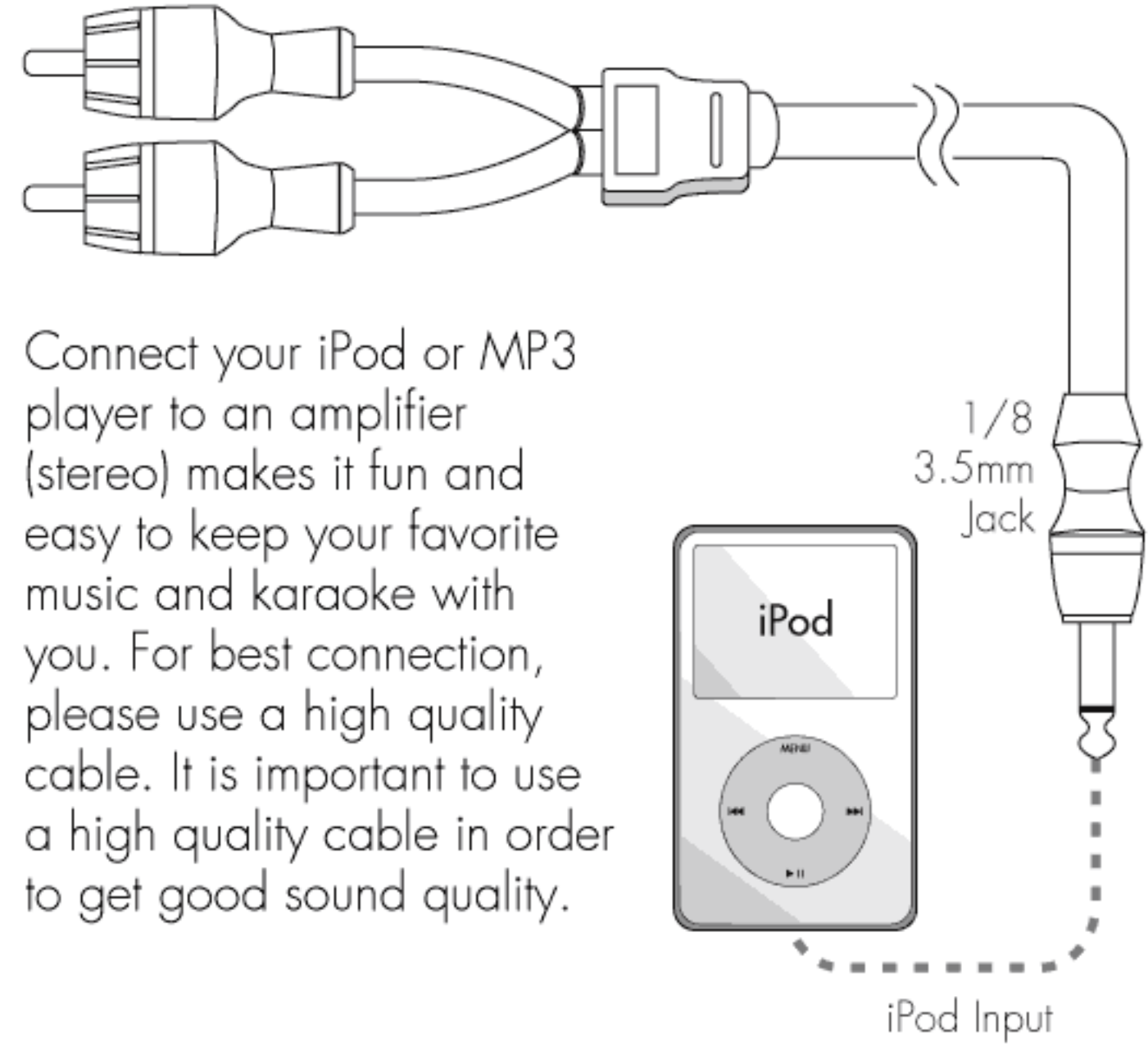

Connect your iPod or MP3 player to an amplifier (stereo) makes it fun and easy to keep your favorite music and karaoke with you. For best connection, please use a high quality cable. It is important to use a high quality cable in order to get good sound quality.

RCA TO 1/4 CABLE

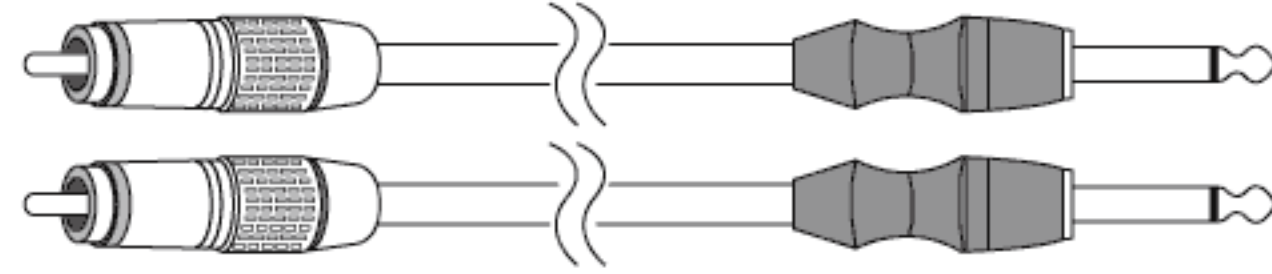

AUDIO OUTPUT CENTER

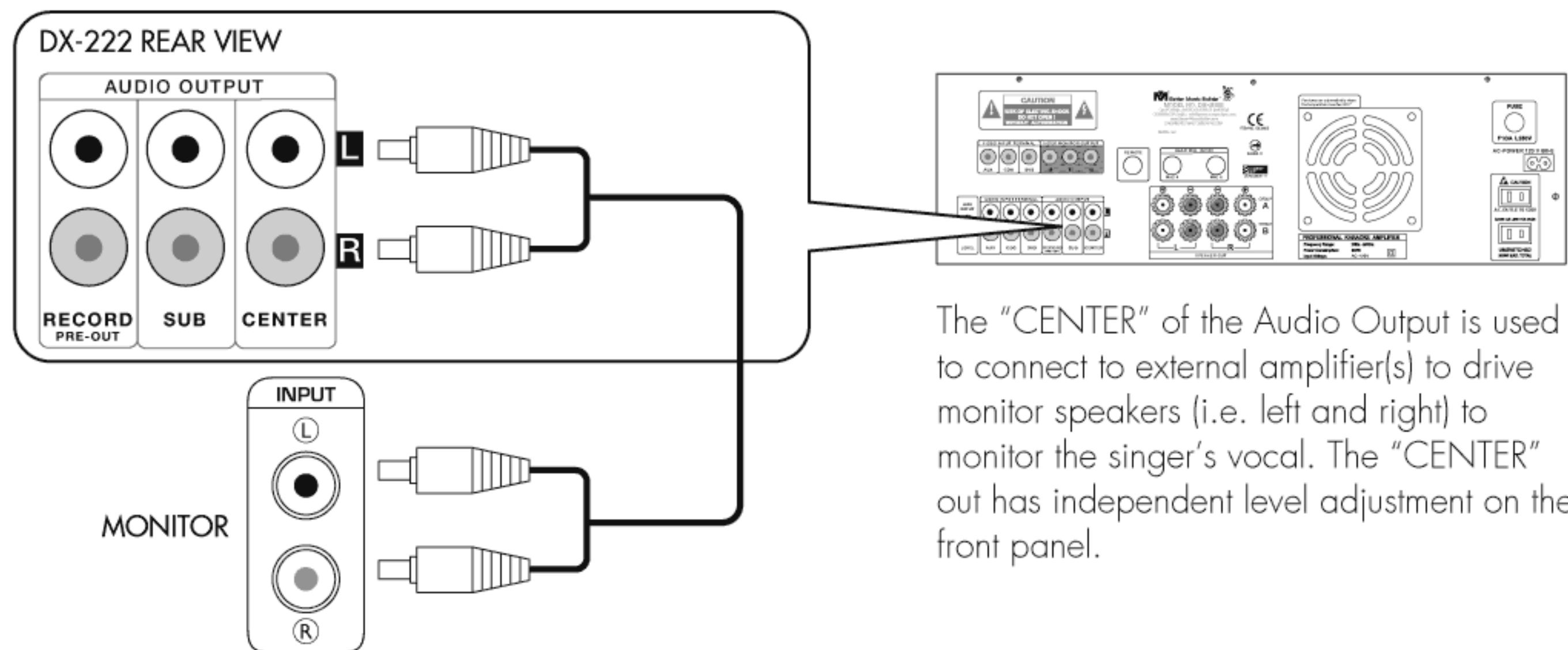

The "CENTER" of the Audio Output is used to connect to external amplifier(s) to drive monitor speakers (i.e. left and right) to monitor the singer's vocal. The "CENTER" out has independent level adjustment on the front panel.

AUDIO OUTPUT SUBWOOFER

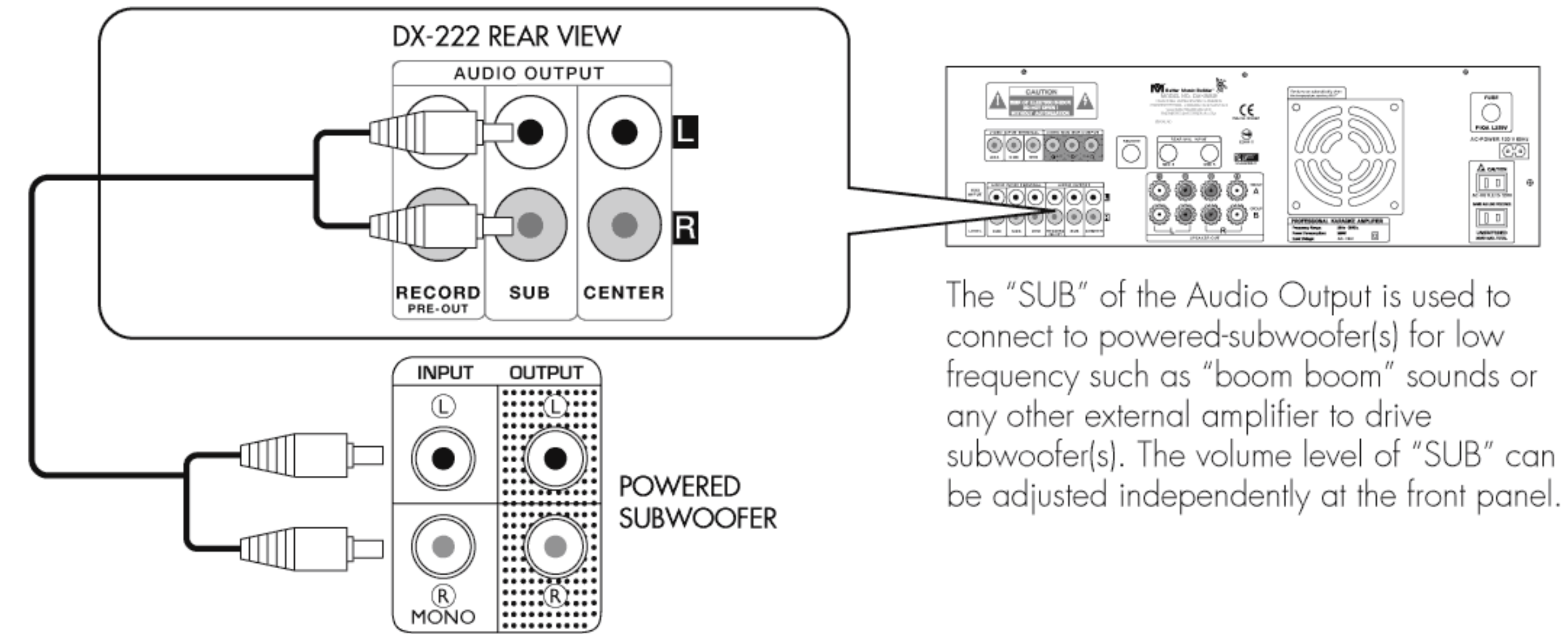

The "SUB" of the Audio Output is used to connect to powered-subwoofer(s) for low frequency such as "boom boom" sounds or any other external amplifier to drive subwoofer(s). The volume level of "SUB" can be adjusted independently at the front panel.

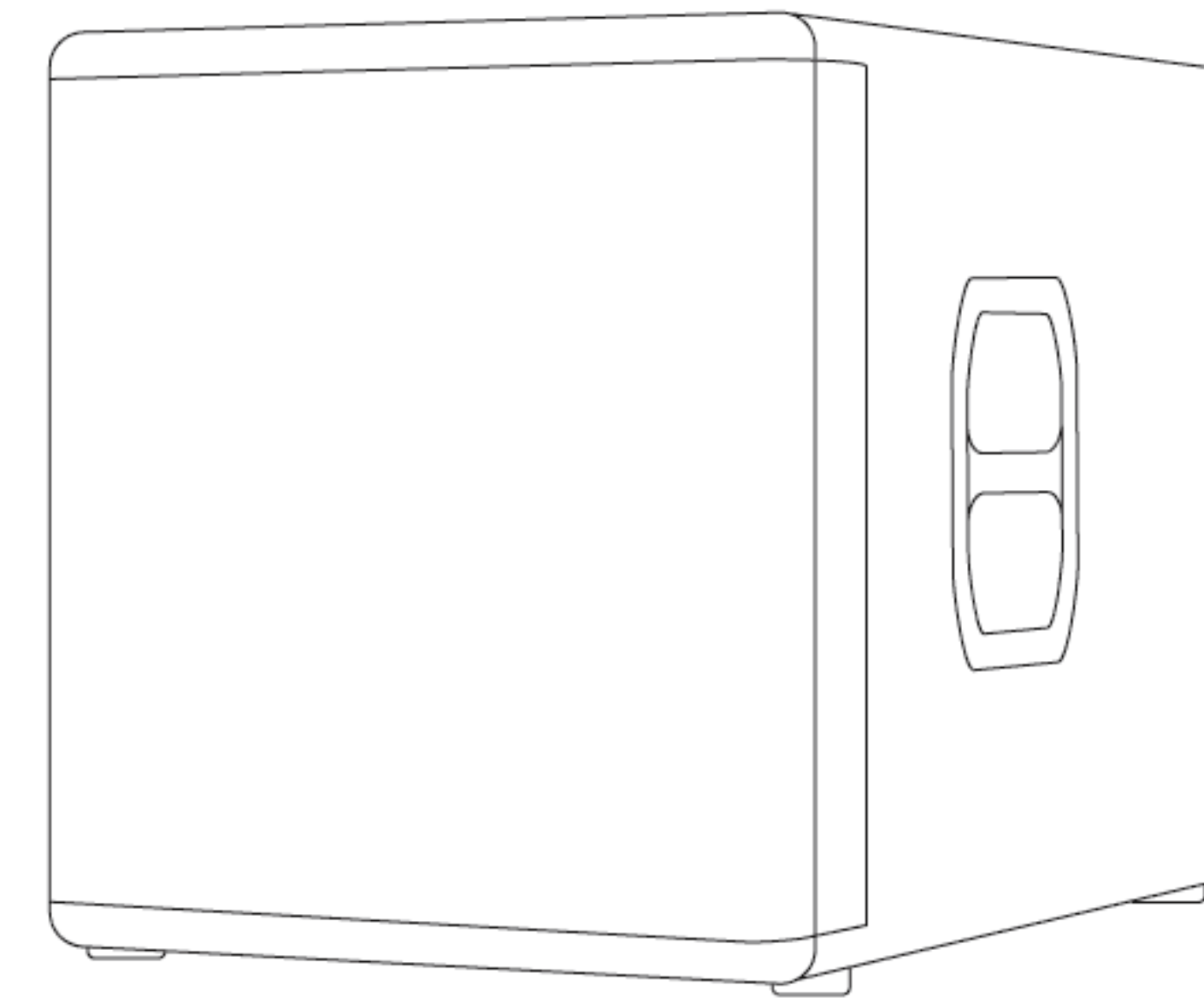

SUBWOOFER FRONT VIEW

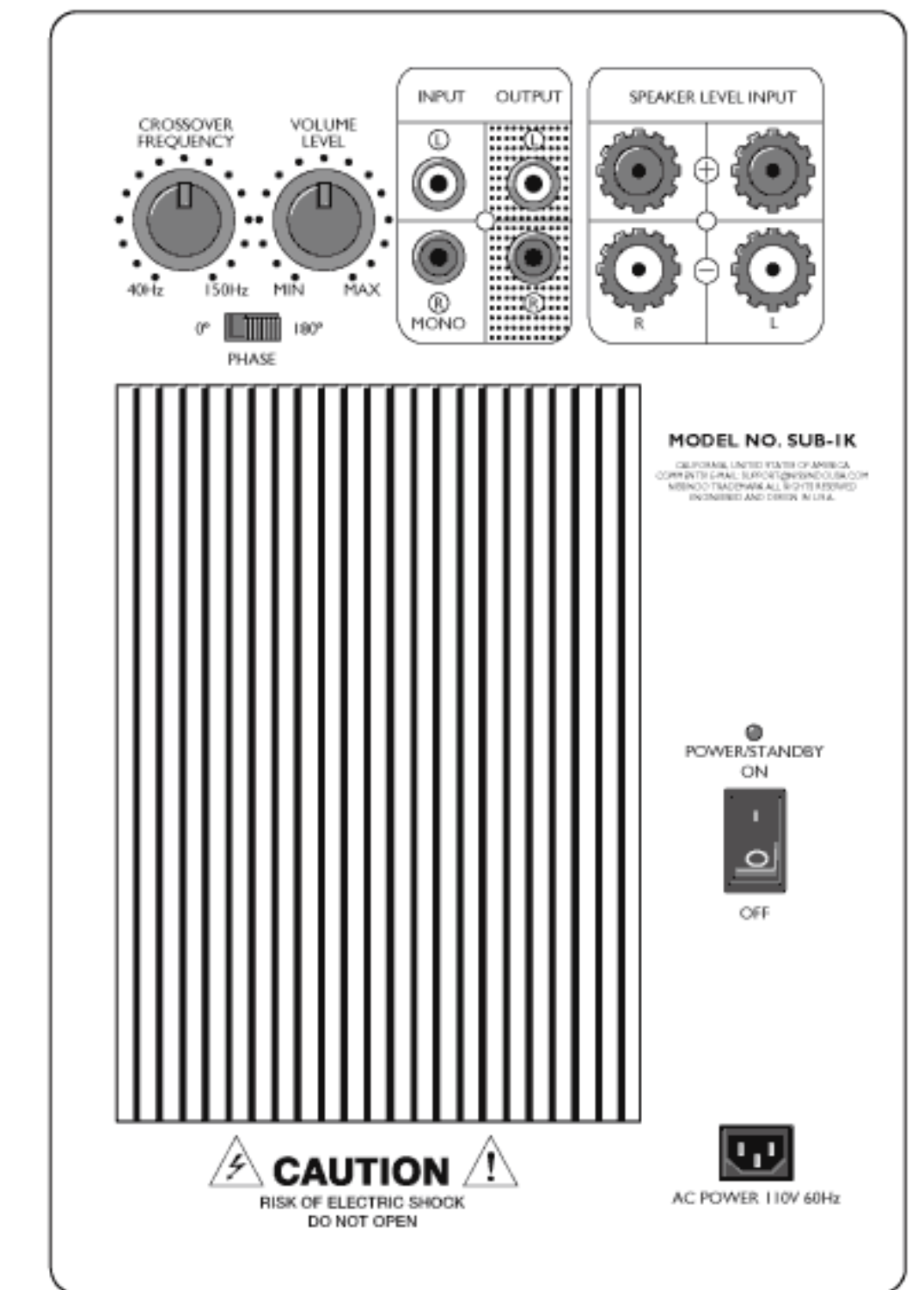

SUBWOOFER REAR VIEW

AUDIO OUTPUT RECORD

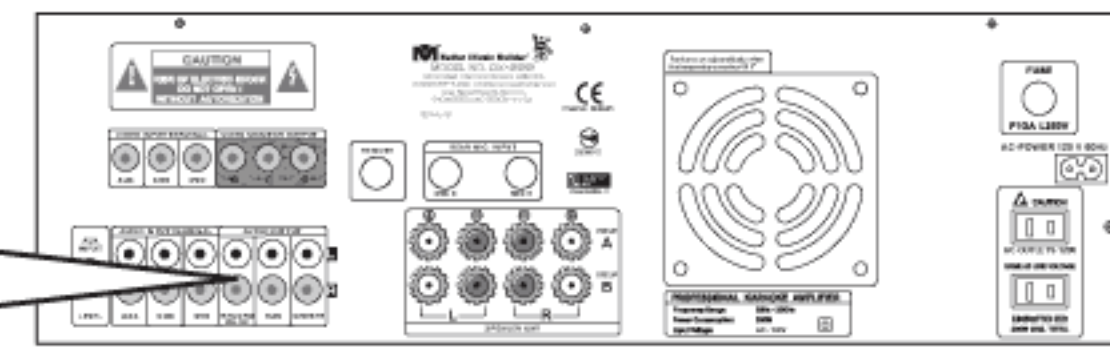
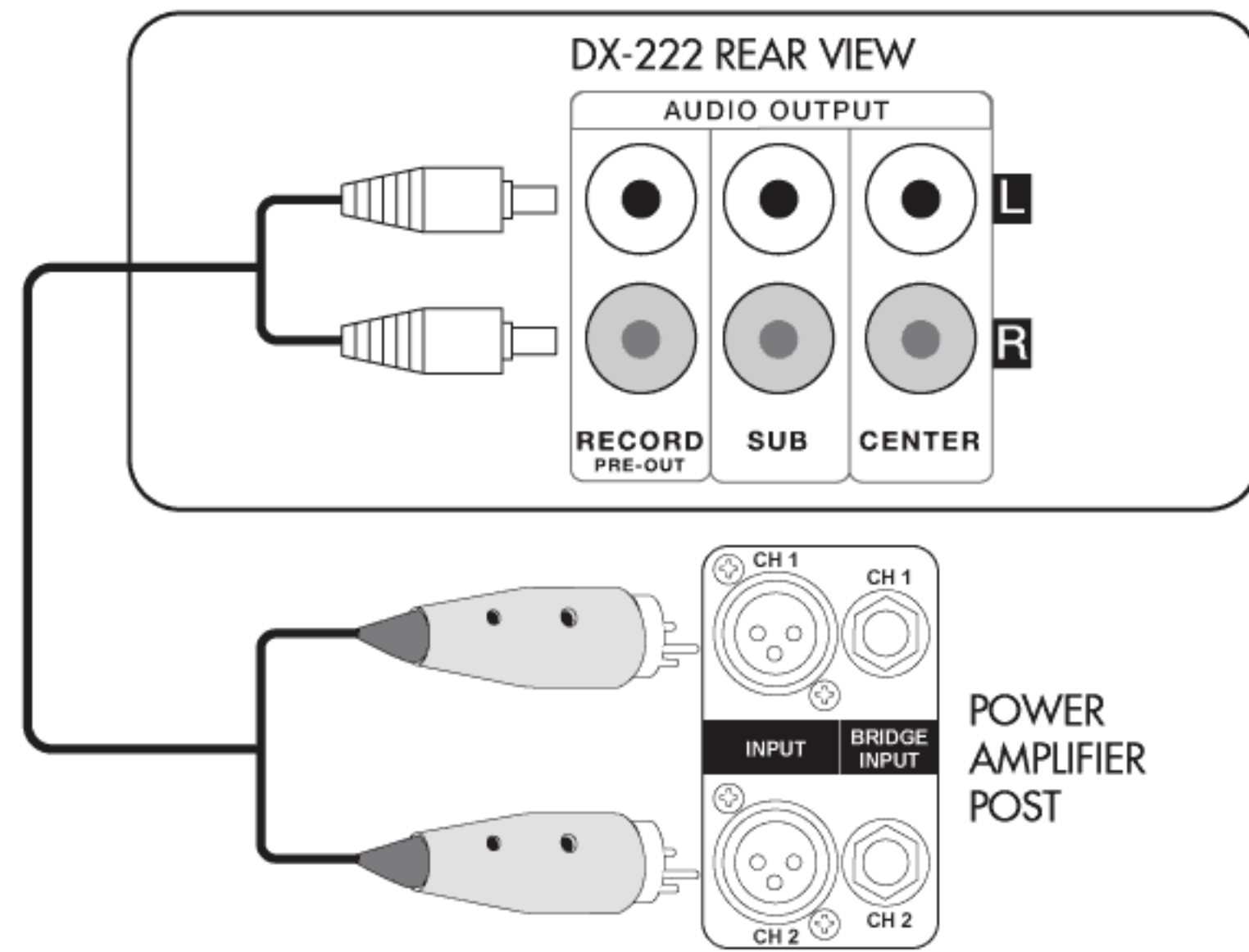

The "RECORD" of the Audio Output has the same signal as that of the main output, so you can use it to connect to external amplifier(s) to cover larger space such as coffee shop, restaurant and auditorium, etc. You can use only one amplifier to produce the same output signal for two different locations with independent volume level and/or tone control.

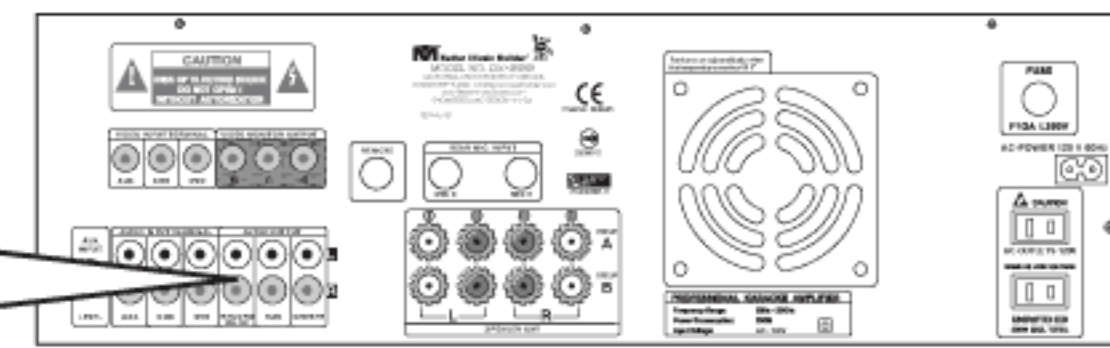
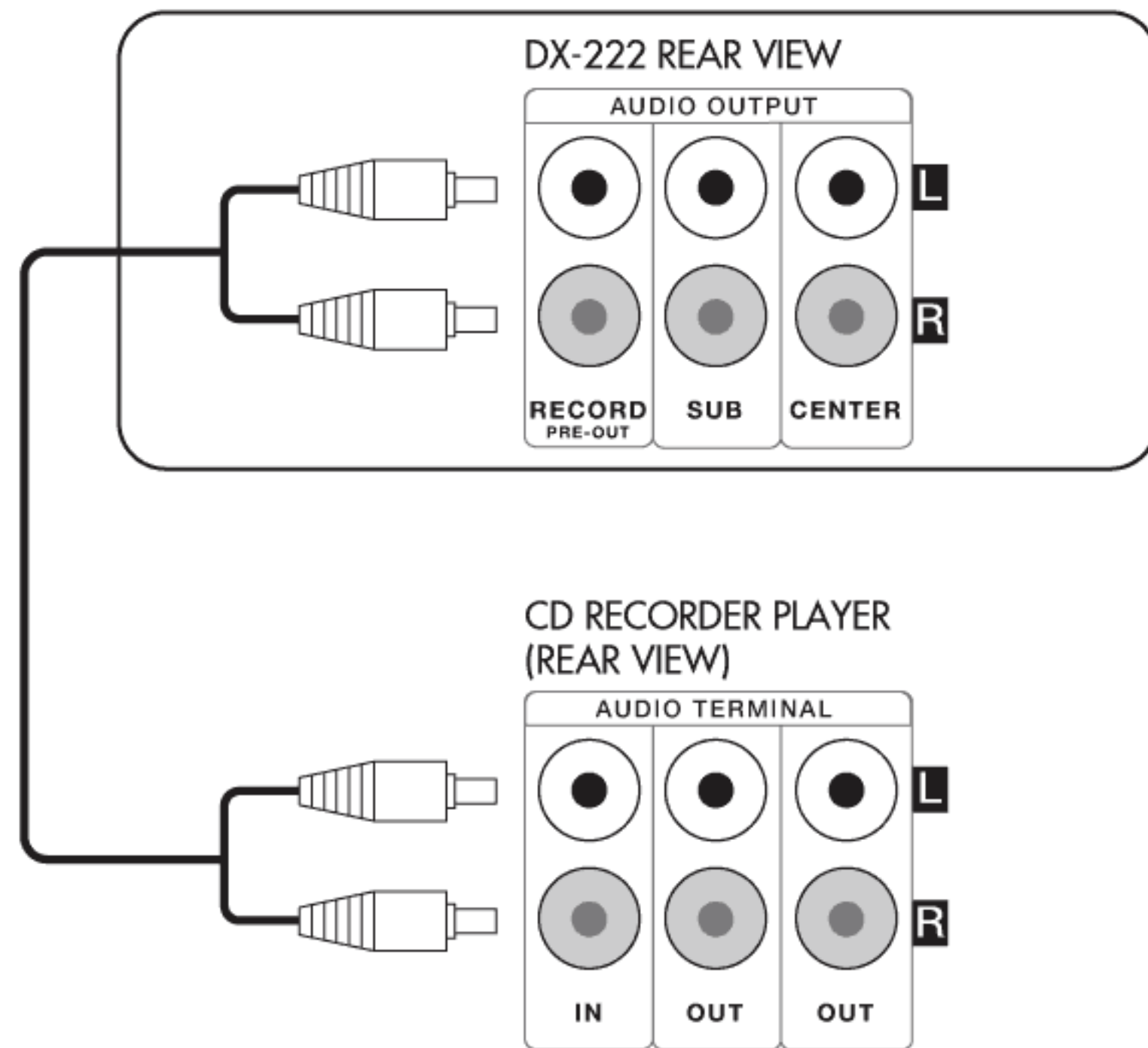

The "RECORD" of the Audio Output is used to connect to a recorder. It has the same signal as the main output. Therefore, it can be connected to an external amplifier. To learn how to connect, please refer to page 30.

HOW TO CONNECT MICROPHONE

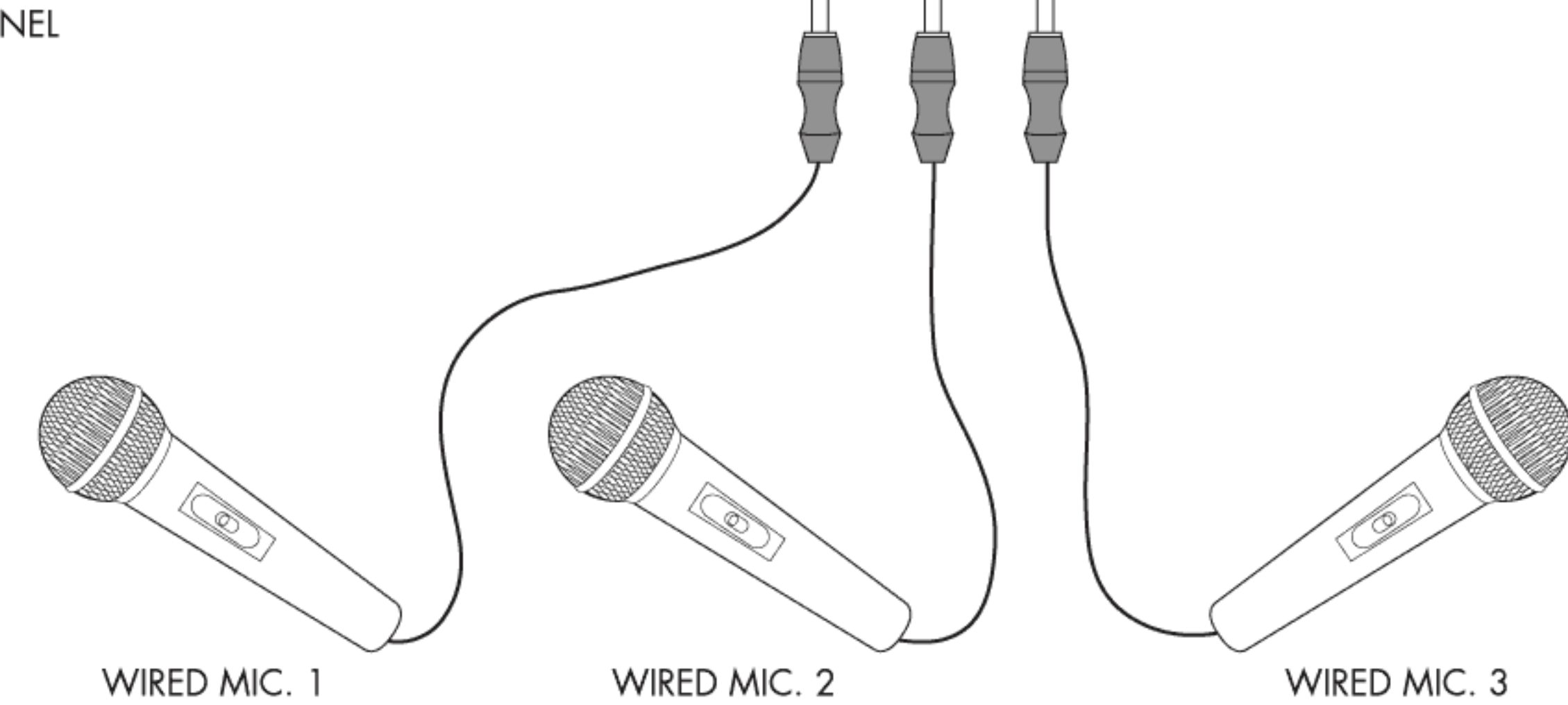
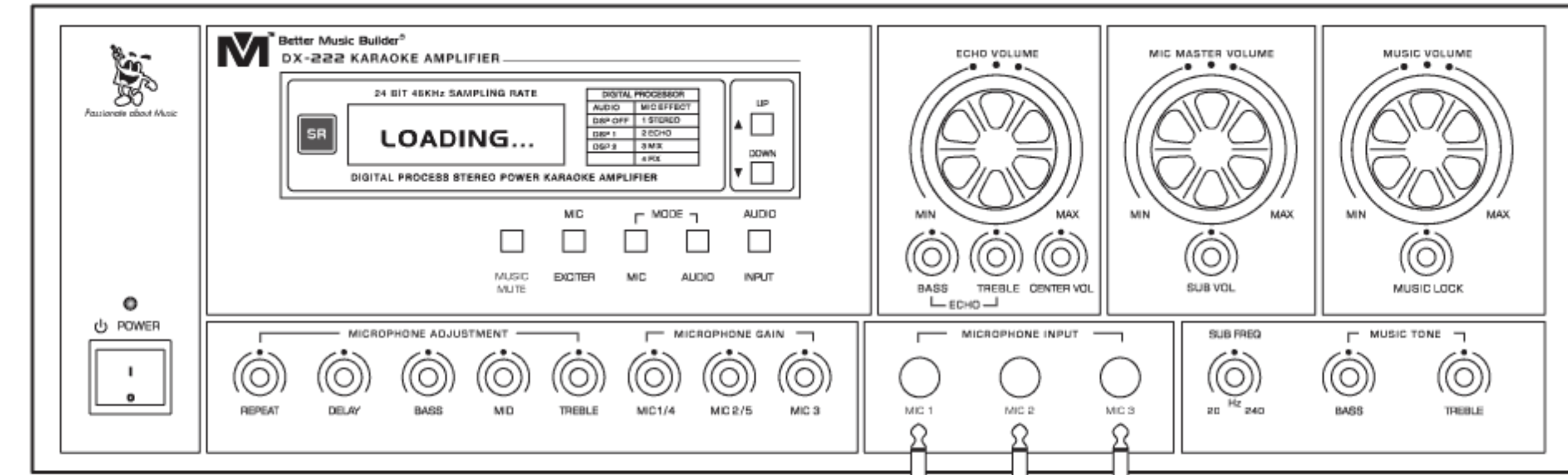

NOTE
Adjust Mic Master Volume to 0 dB before inserting 1/4" microphone plugs into mic inputs to avoid unpleasant noise and protect your equipment from damage.

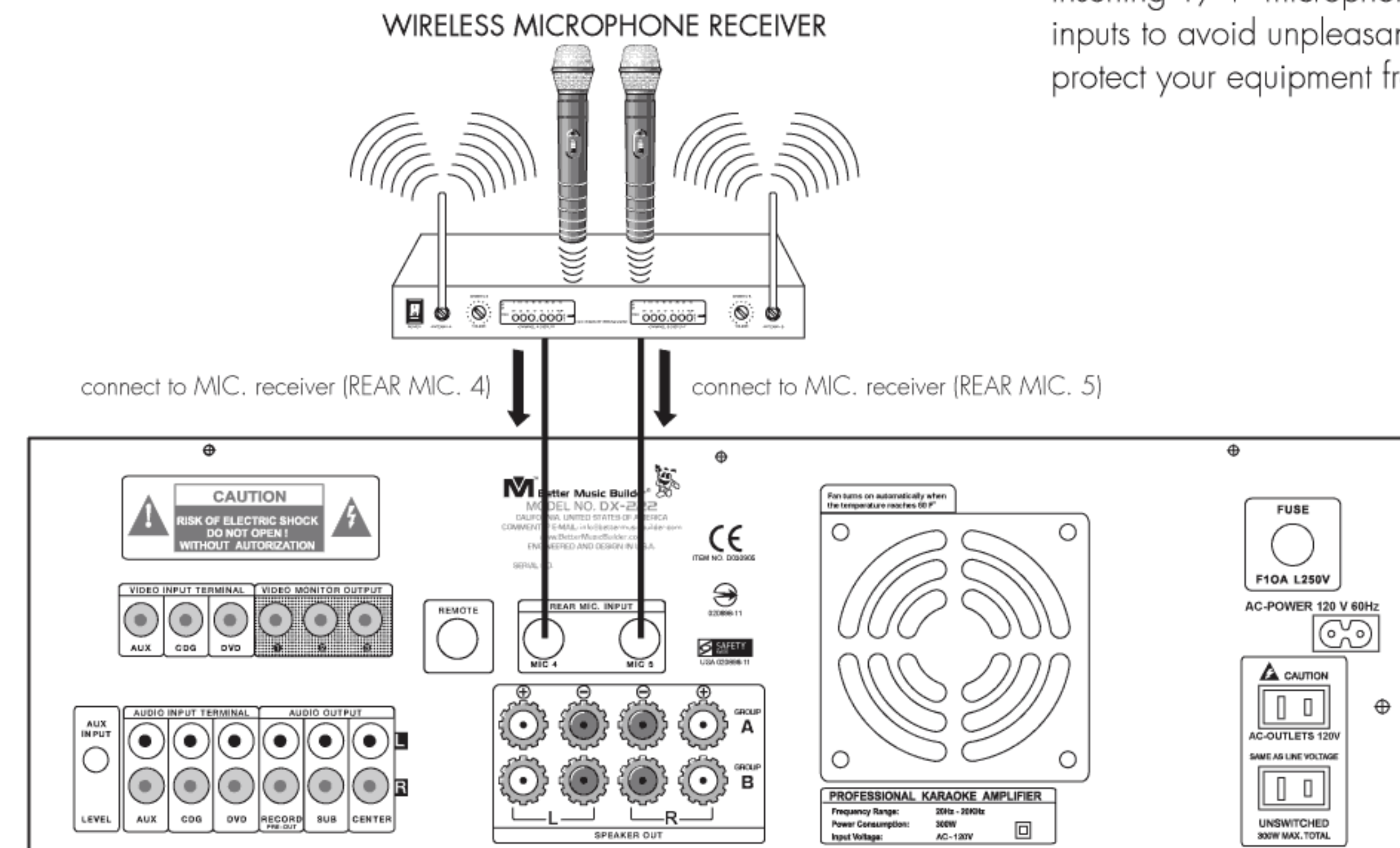

REAR PANEL

OPERATING INSTRUCTIONS

1. Turn on the DX-222 by flipping the power switch to the ON (I) position.

2. After turning the machine on, it takes about 40 seconds to boot it up for operation.

3. After the machine has been booted up, the Digital Display (VFD) would appear as follows:

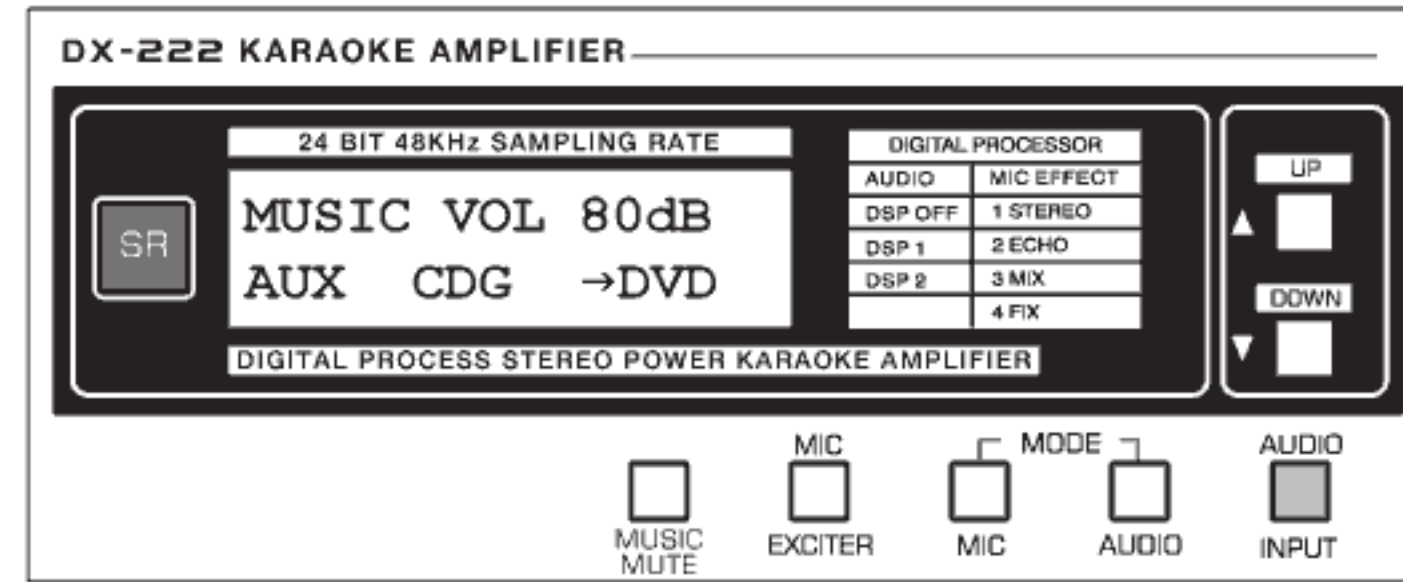

AUDIO INPUT

4. Press the AUDIO INPUT button to select the source as follows:

This machine is specially designed for Karaoke business and in such a way that DVD has the first priority for input selection. When nobody is singing Karaoke in the room, the machine would turn to commercial advertising. When someone wants to sing, the machine would return to DVD (Karaoke mode with the first priority).

For input selection, press the INPUT/SELECT button to move the arrow to select the source: DVD, AUX or CDG. DVD has the first priority; AUX and CDG have the second and the lowest priorities respectively. That's why the machine always chooses DVD after power is up. If you want to select CDG you have to turn off the source connected to DVD. For example, in a karaoke bar, CDG can be used to play background music while DVD is connected to the main mixer where the microphones are plugged in. When the DJ makes an announcement through the microphone, the built-in CPU will automatically select DVD and you will not hear the background music. Instead, you will only hear the DJ's voice or whatever signal source (for example, commercial advertising) is plugged into the main mixer. You may learn more on DVD from page 32 under "DVD Connection for Home" and 33 under "DVD Connection for Commercial."

MODE ADJUSTMENT (MIC, AUDIO)

5. Music DSP Effect Mode

Press the audio mode button once, the screen will appear as follows. You may select your favorite mode by pressing the UP/DOWN button.

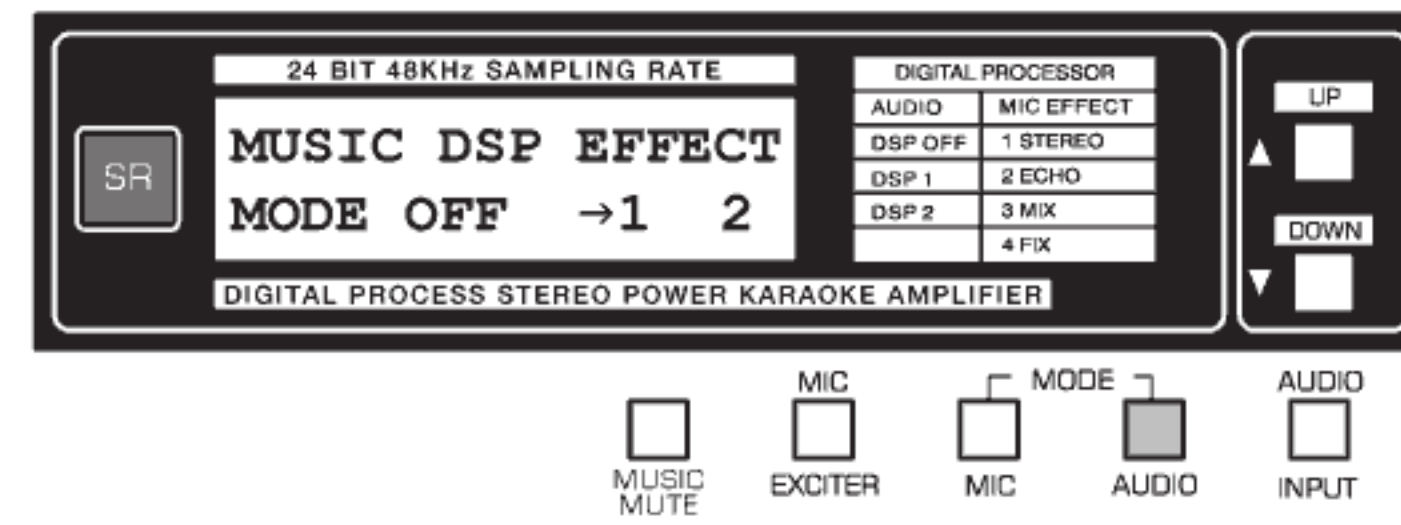

NOTE

"1" is to simulate disco; "2" is to simulate hall.

6. Key Control

Press the Audio mode button twice and use UP/DOWN button to select your favorite Key.

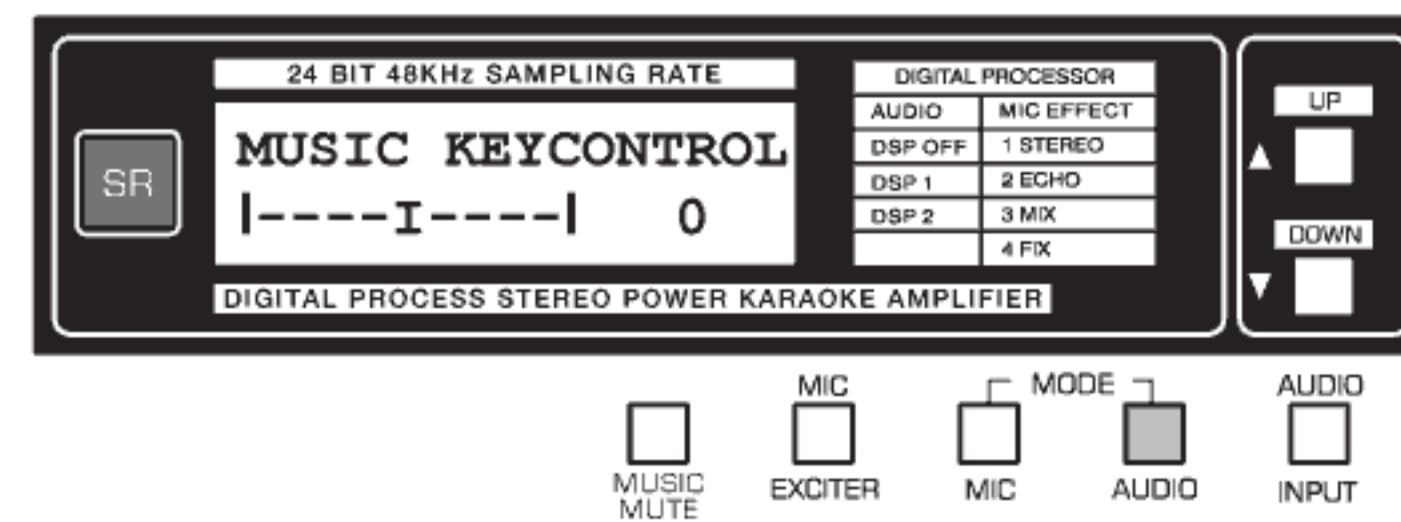

7. MIC Effect Mode

Press the mic mode button once, the screen will appear as follows: you may select Mic Effect 1, 2, 3 or Fix by using UP/DOWN button.

NOTE

Mic Effect 1, 2 and 3 are factory preset. Fix is to lock the user's favorite microphone effect settings. Once fix is selected all microphone effect adjustments (REPEAT, DELAY, and ECHO VOLUME) can't be changed.

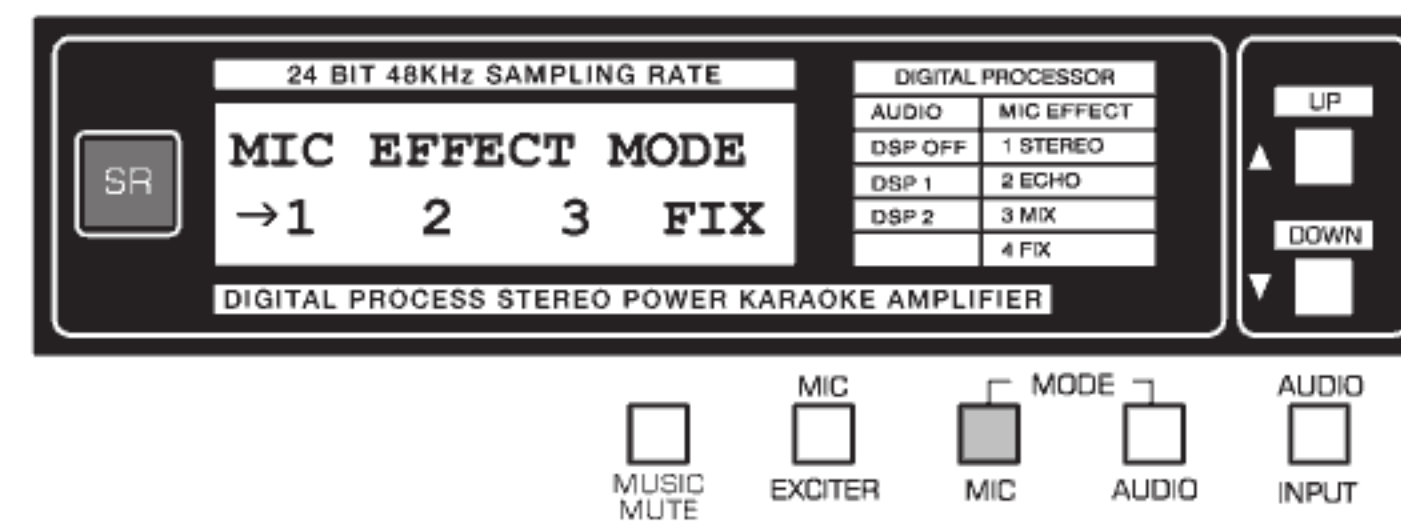

8. Mic Volume Lock

Press the Mic Mode button twice and the screen will appear as follows. Use UP/DOWN button to turn MIC VOL LOCK on or off.

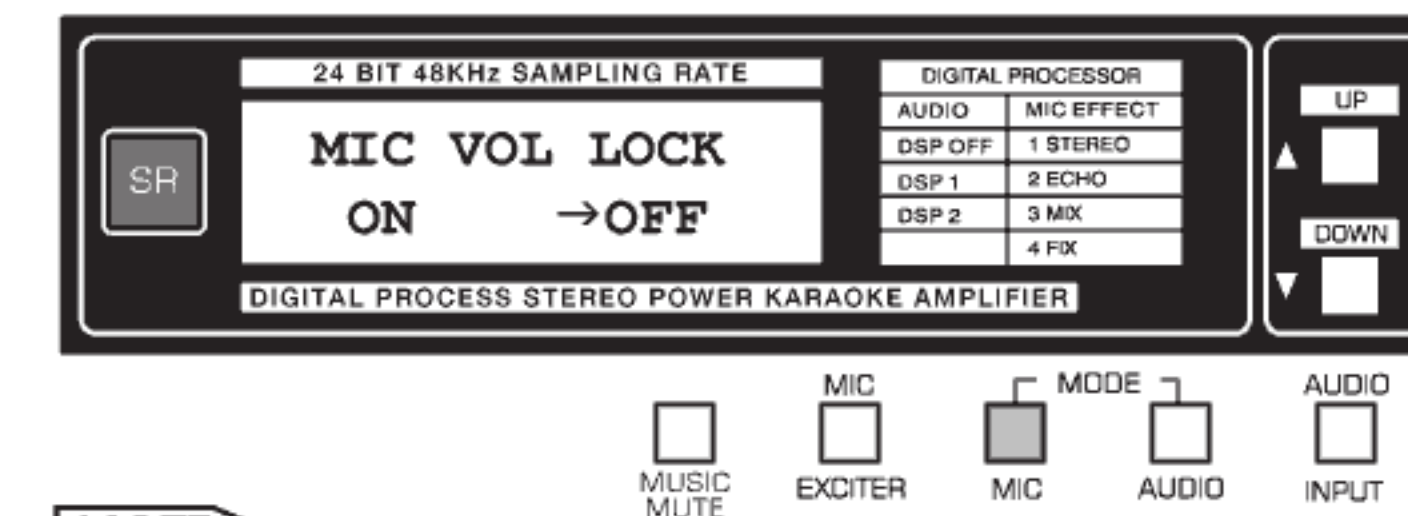

NOTE

Once the MIC VOL LOCK is on, you can no longer adjust the mic. volume level and/or the echo volume level.

9. Mic Exciter Button

The first screen will show as below: You may press the UP/DOWN button to turn ON/OFF. When the Exciter is on, it will increase the mic. signal sensitivity.

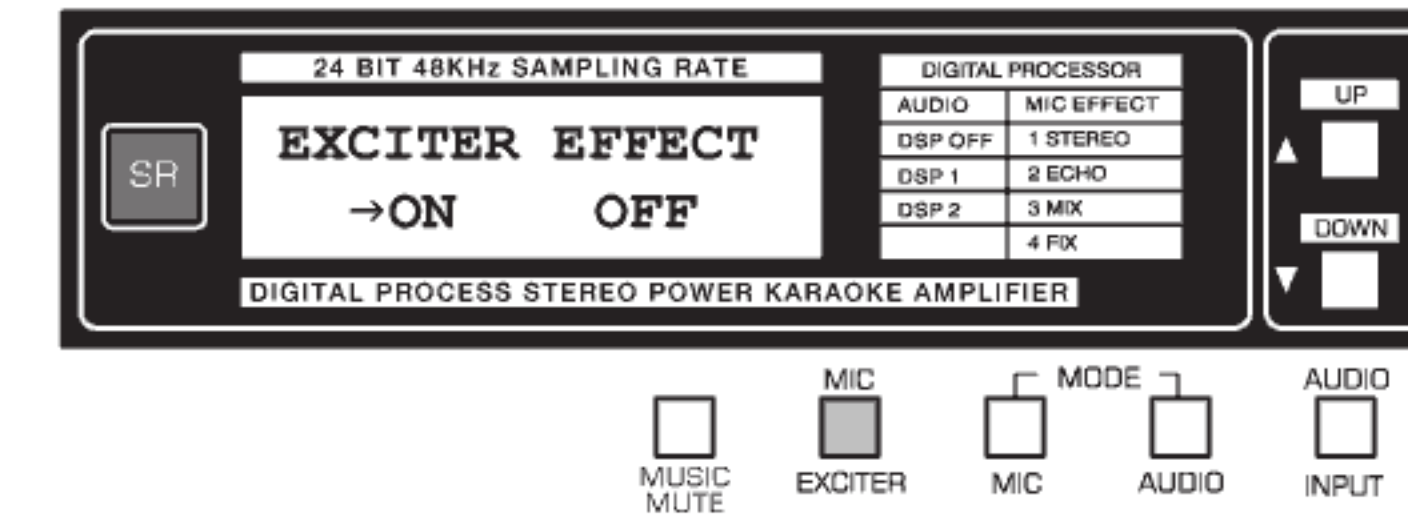

10. Mute Button (Music OFF only)

Press this button to mute all music input (DVD, CDG, VOD) signals, but microphone input is still active.

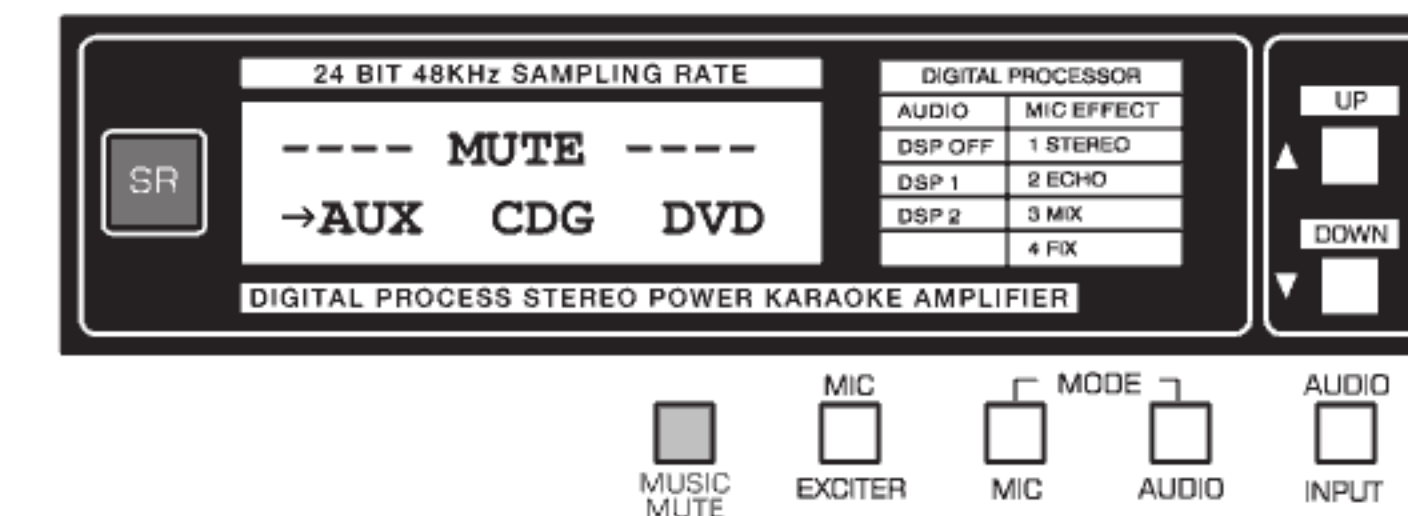

11. Mic Master Volume Adjustment

Turn MIC MASTER VOLUME clockwise to increase and counter clockwise to decrease mic. volume level.

NOTE

The MIC MASTER VOLUME has a range of 00 dB to 40 dB.

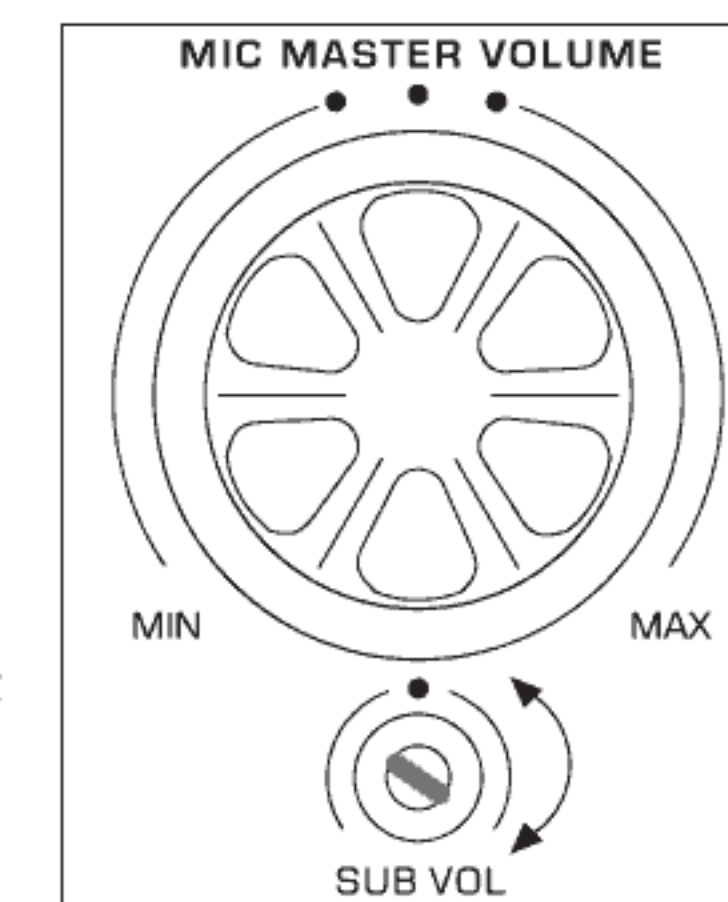

12. Microphone Adjustment

REPEAT, DELAY, BASS, MID, and TREBLE can be adjusted individually by turning each pot.

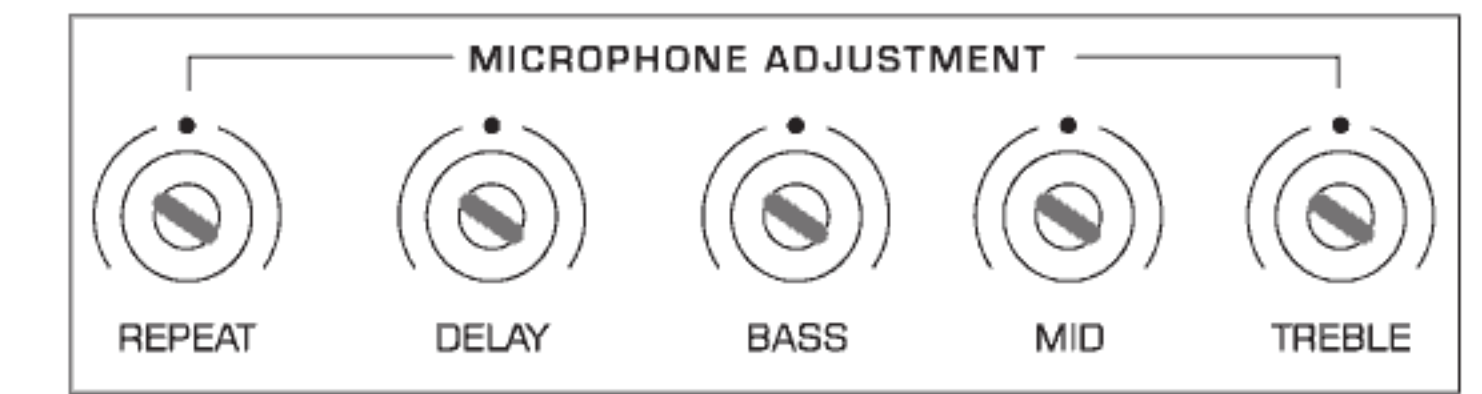

13. Microphone Gain Adjustment

Turning each pot adjusts gain of the corresponding microphone.

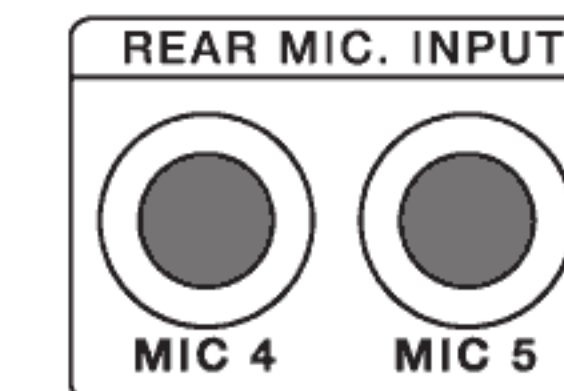
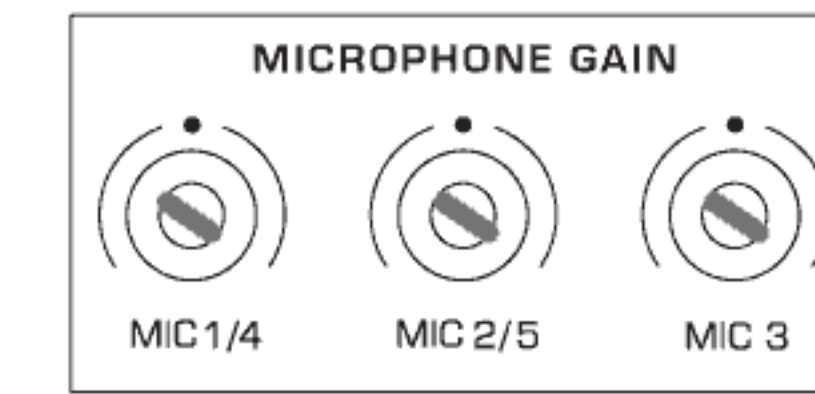

NOTE

MIC 1, 2, and 3 refer to the three front Mic. input jacks and MIC 4 and 5 refer to the two rear Mic. jacks. Adjusting MIC 1/4 will affect both Mic 1 and Mic 4 at the same time.

Adjusting the MIC 2/5 pot will affect both Mic 2 and Mic 5 at the same time.

The two rear Mic. input jacks can be used for wireless microphone system for a neater appearance.

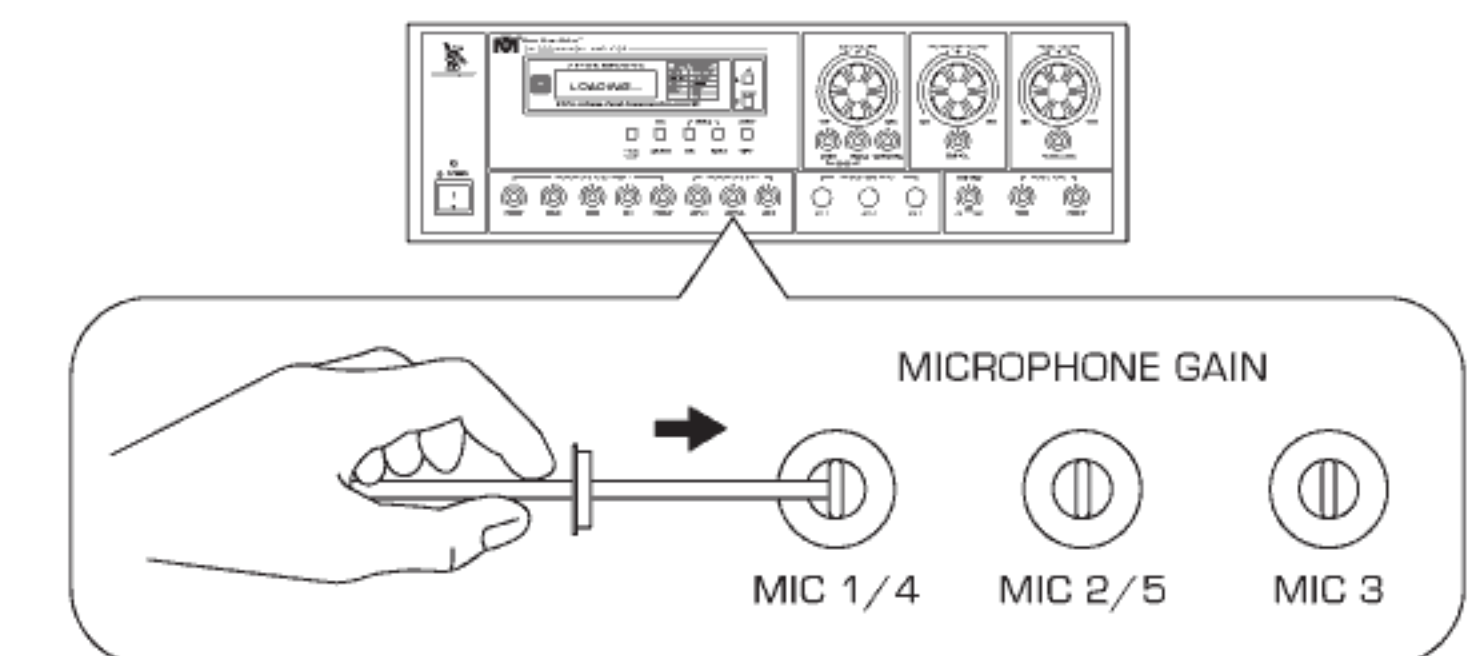

14. Echo Volume Adjustment

Turn ECHO VOL clockwise to increase and counterclockwise to decrease the echo volume level.

NOTE

The echo volume ranges from 00 dB to 31 dB.

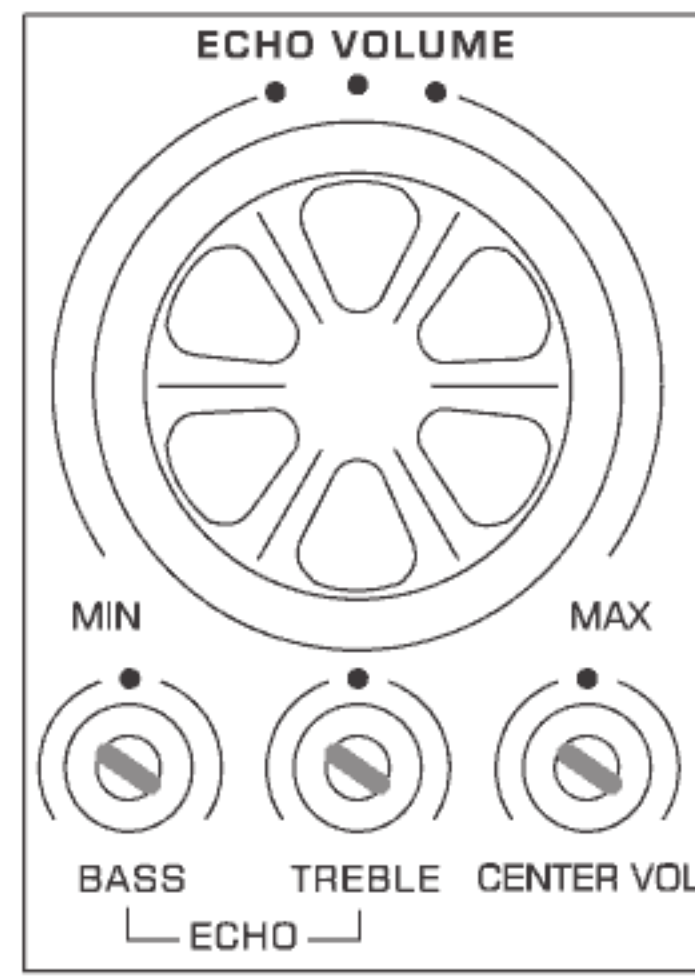

Figure 1

15. Echo Bass Adjustment

Use a screw driver to adjust the echo bass output level of the microphones.

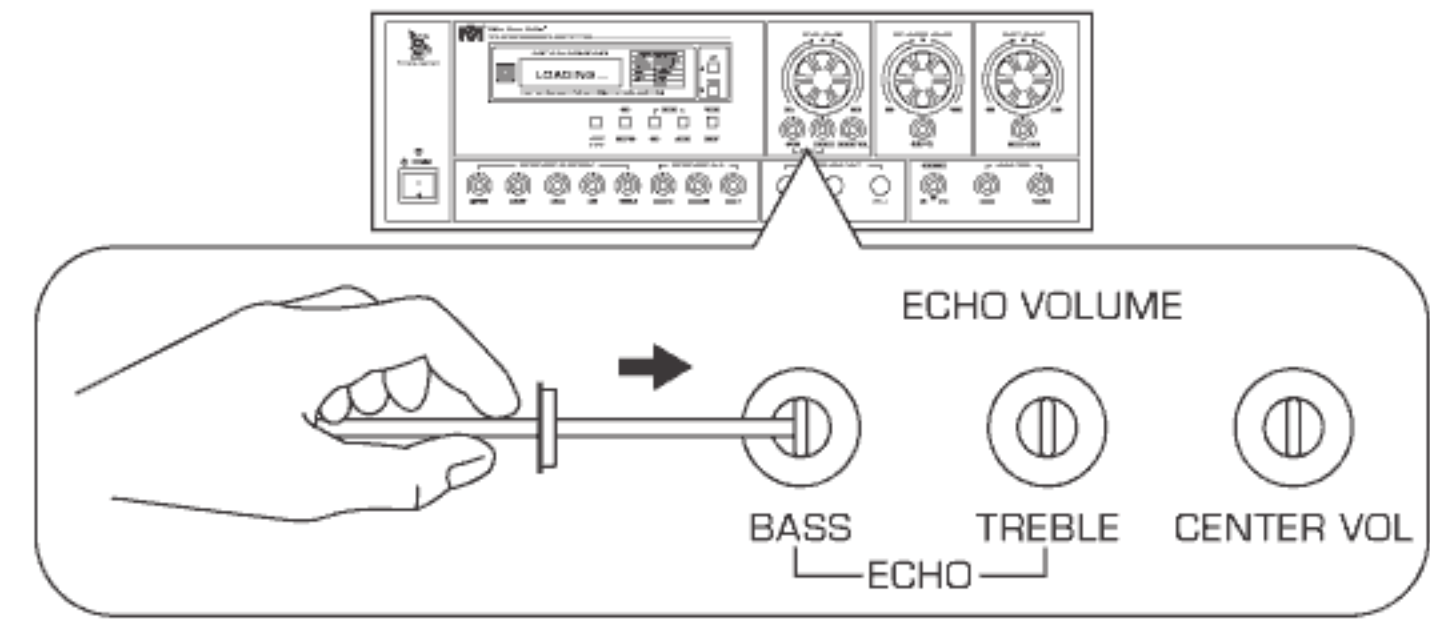

Figure 2

16. Echo Treble Adjustment

Use a screw driver to adjust the echo treble output level of the microphones.

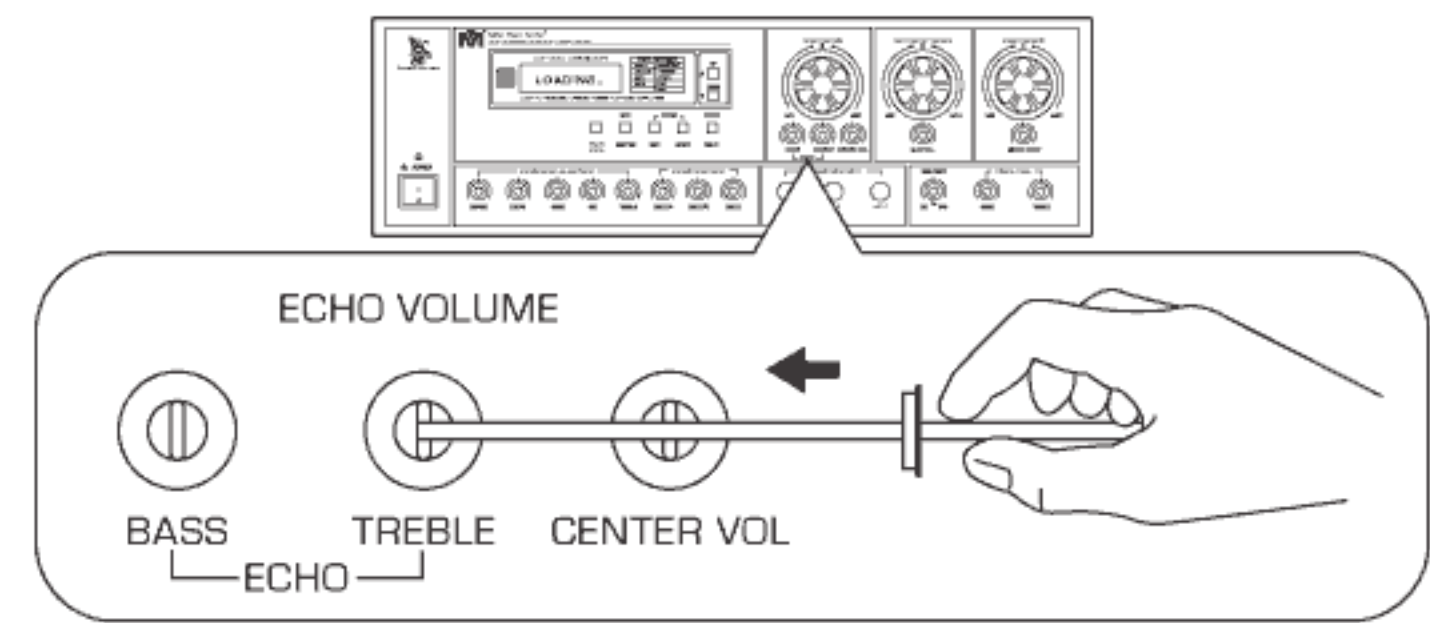

Figure 3

17. Center Speaker Volume Adjustment

Use a screw driver to turn CENTER VOL to adjust the level of the "CENTER" output in the rear panel.

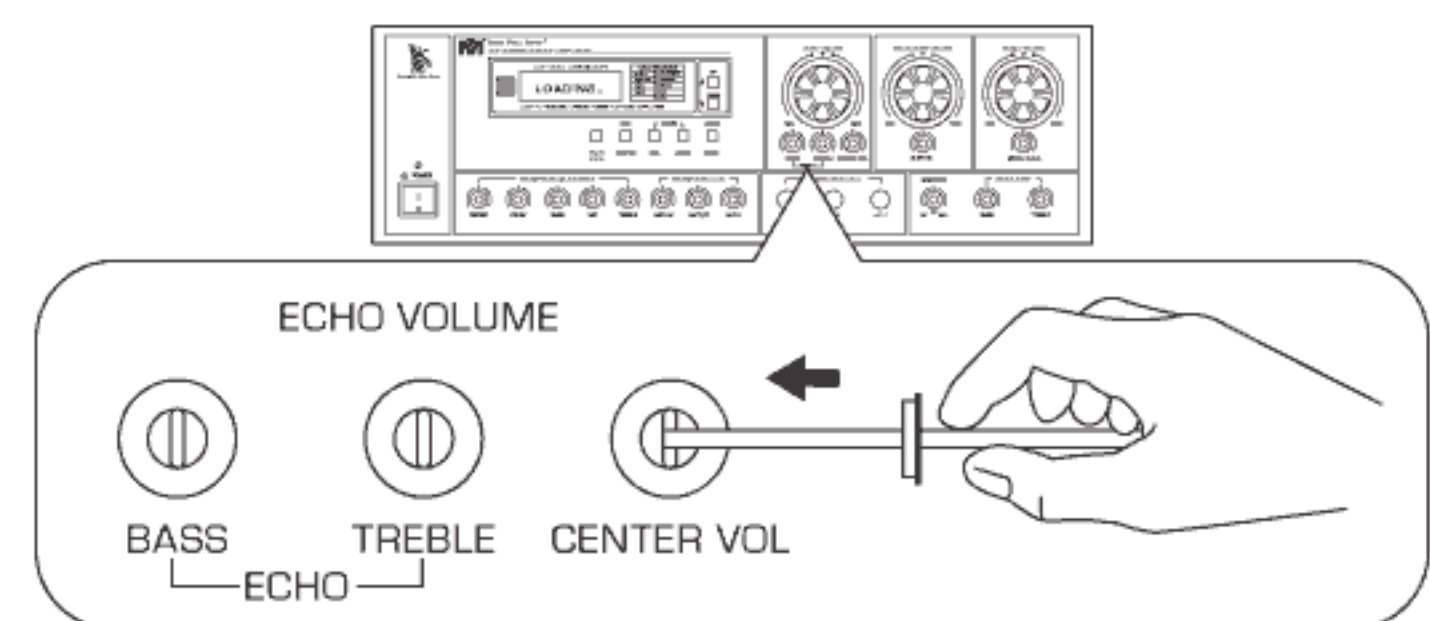

Figure 4

18. Subwoofer Volume

Use a screw driver to turn SUB VOL to adjust the level of the SUB output in the rear panel.

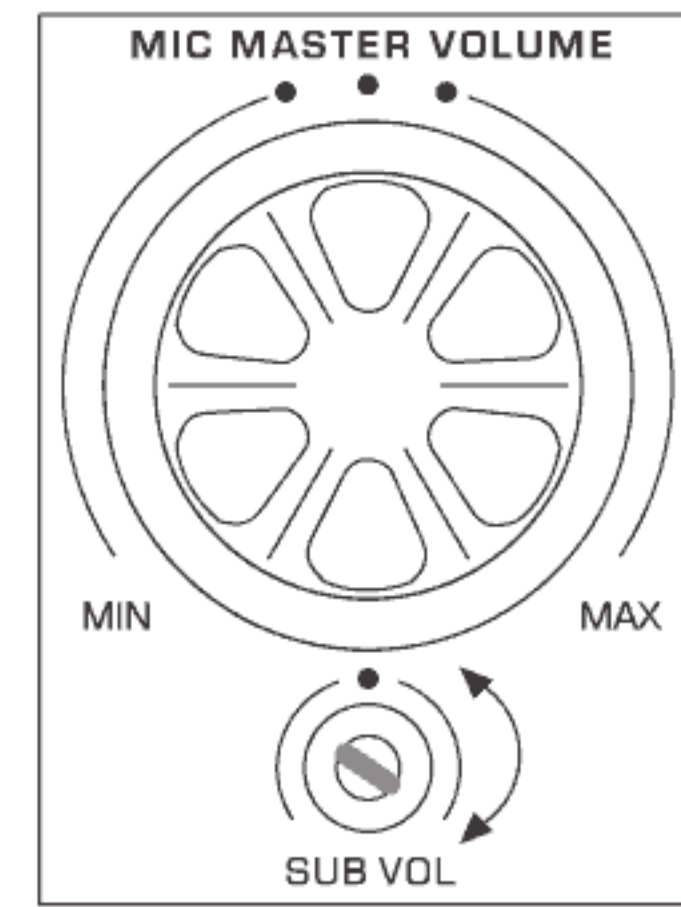

Figure 5

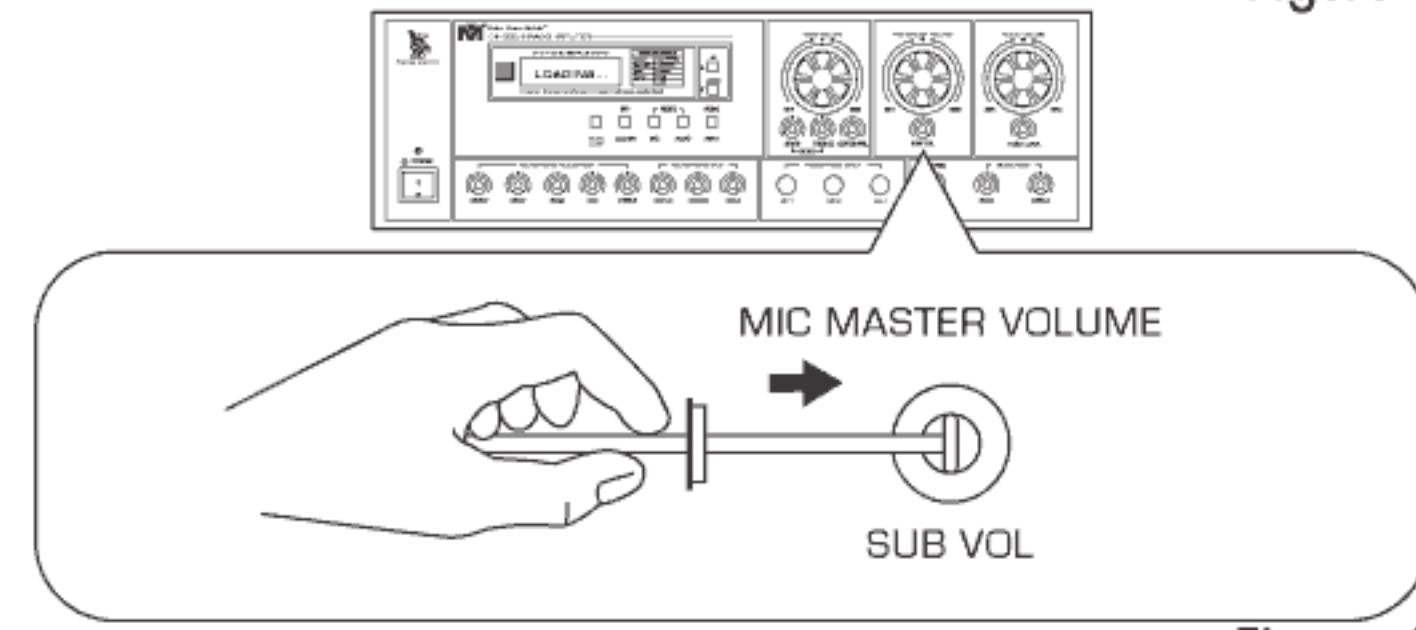

Figure 6

19. Music Volume Adjustment

Turn MUSIC VOL clockwise to increase and counterclockwise to decrease the music volume level.

NOTE

The music volume ranges from 00 dB to 90 dB.

20. Music Lock

Use a screw driver to turn MUSIC LOCK to adjust the maximum output level (52~90dB). This feature is for limiting the output power for speaker protection.

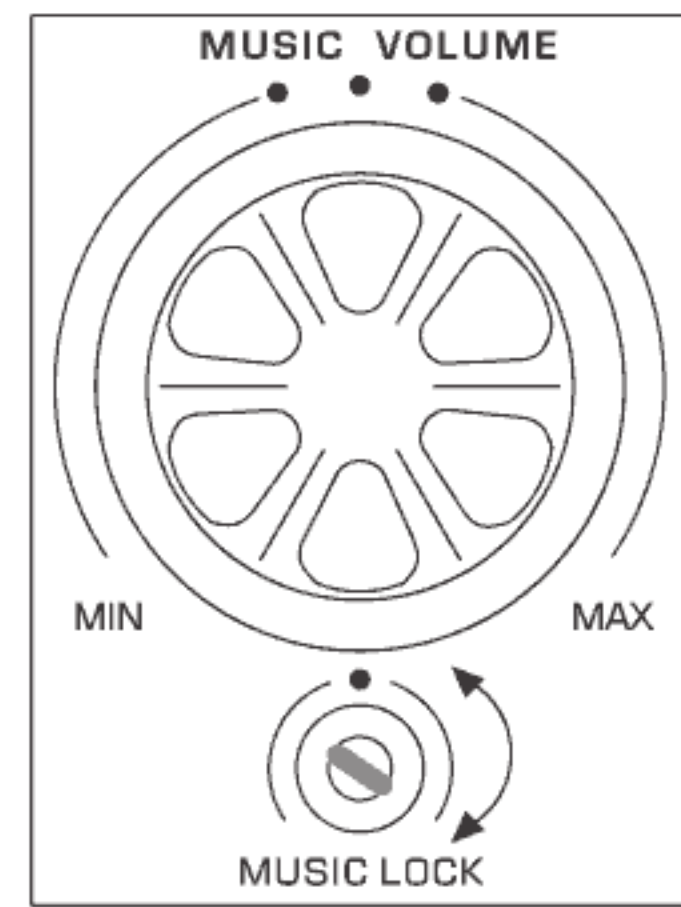

Figure 7

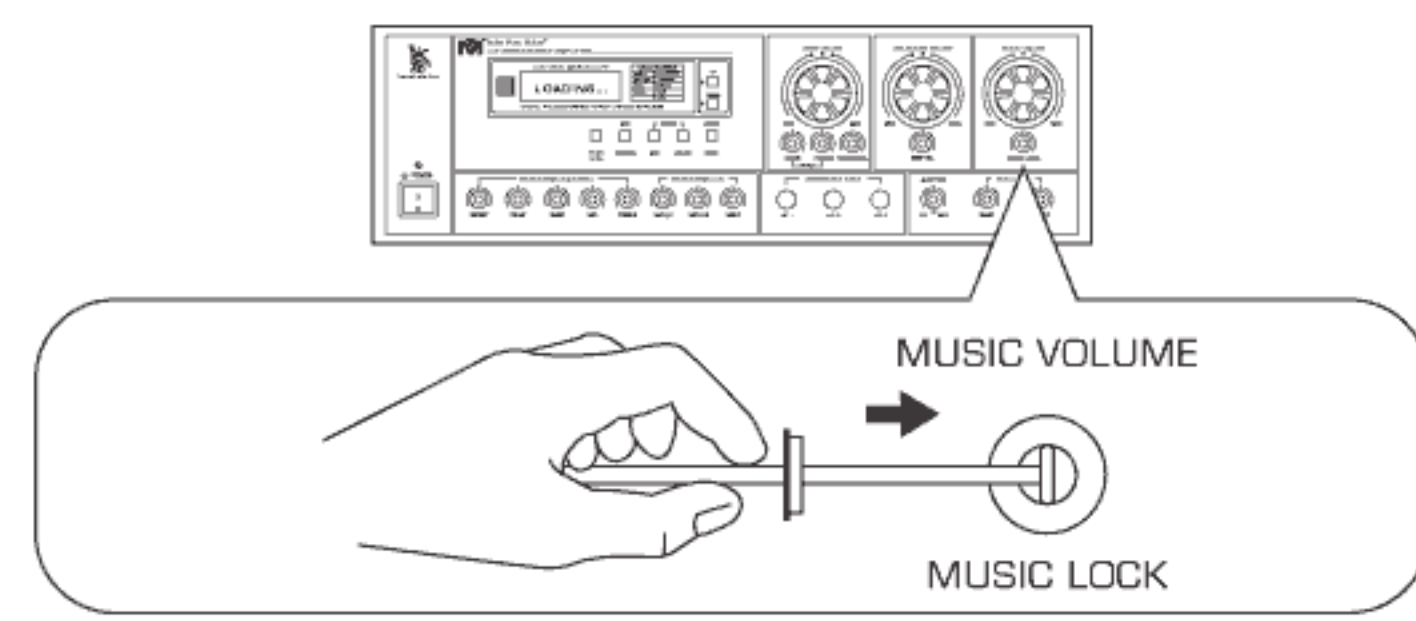
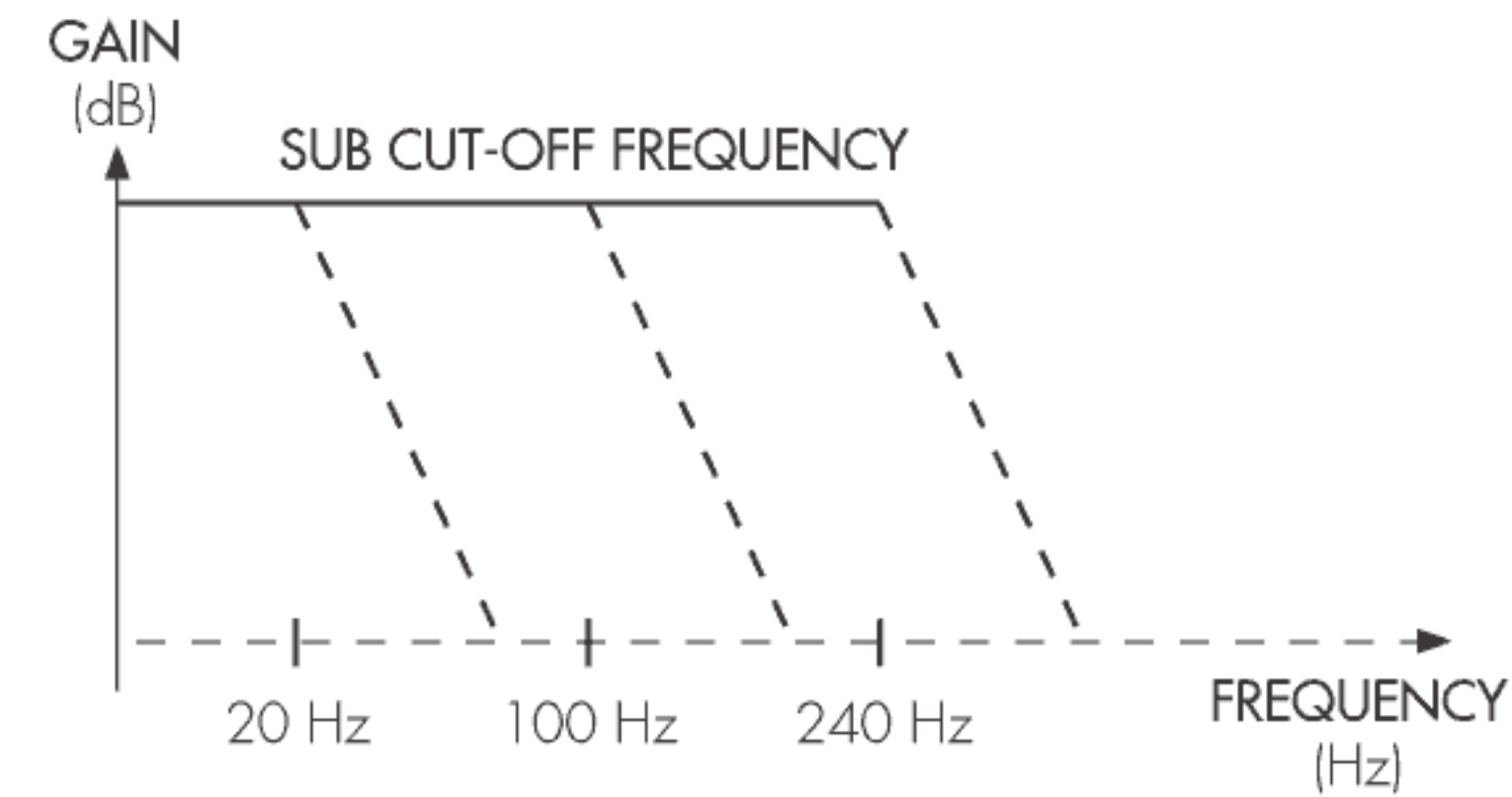
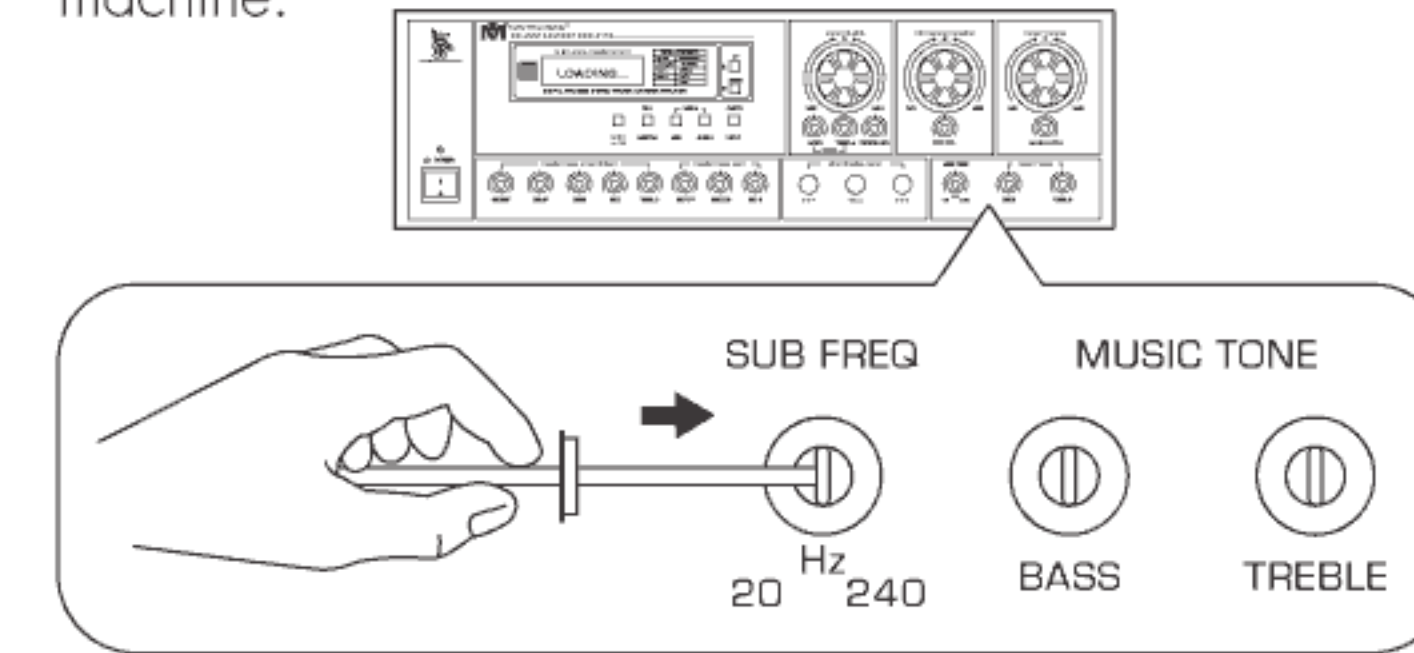

Figure 8

21. Subwoofer Frequency

Use a screw driver to turn SUB FREQ to adjust the cut-off frequency of the SUB output at the rear of the machine.



22. Music Tone

Bass Adjustment: Use a screw driver to turn BASS to adjust the bass output level.

Treble Adjustment: Use screw driver to turn TREBLE to adjust the treble output level.

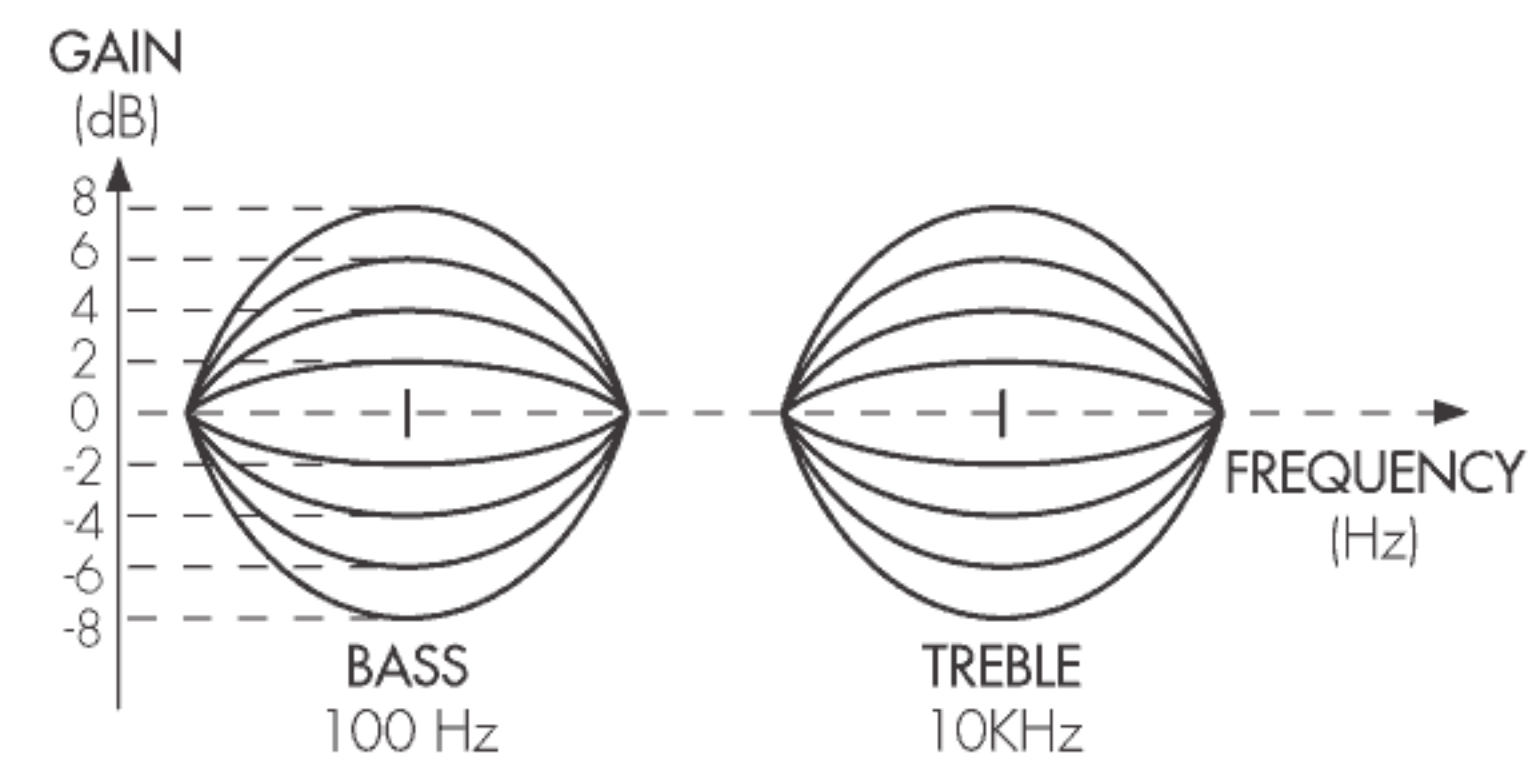
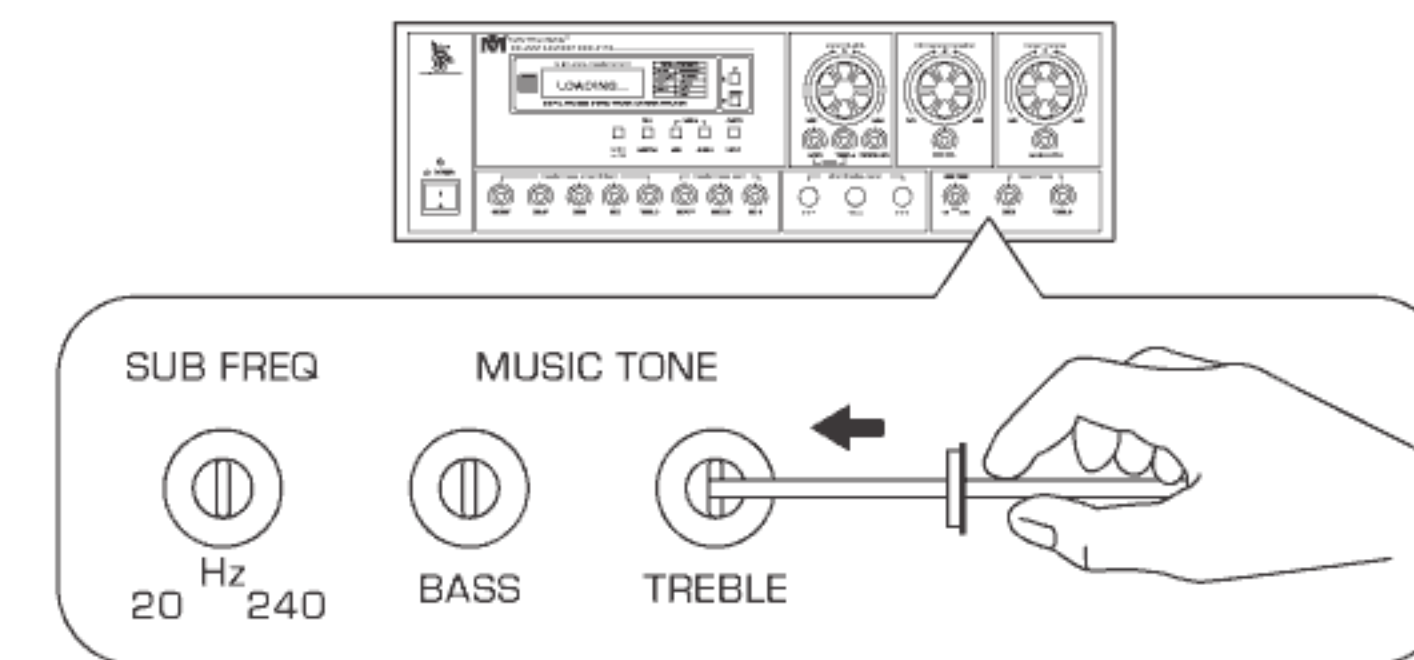

23. Setting the Memory for Your Favorite Volume Level

Turn the knob to adjust to your favorite volume level, then press the UP and Down buttons simultaneously for 3 seconds. These actions will set the system memory, so that every time when you turn on the power for the machine, it will automatically start at the pre-set favorite volume level. The above instruction is applicable to "Echo Volume," "MIC Master Volume" and "Music Volume." However, you must repeat the above procedures for each one.

ECHO VOLUME 00dB |-----| 31dB
minimum maximum

MIC MASTER VOLUME 00dB |-----| 40dB
minimum maximum

MUSIC VOLUME 00dB |-----| 90dB
minimum maximum

ECHO VOLUME
MIC MASTER VOLUME
MUSIC VOLUME

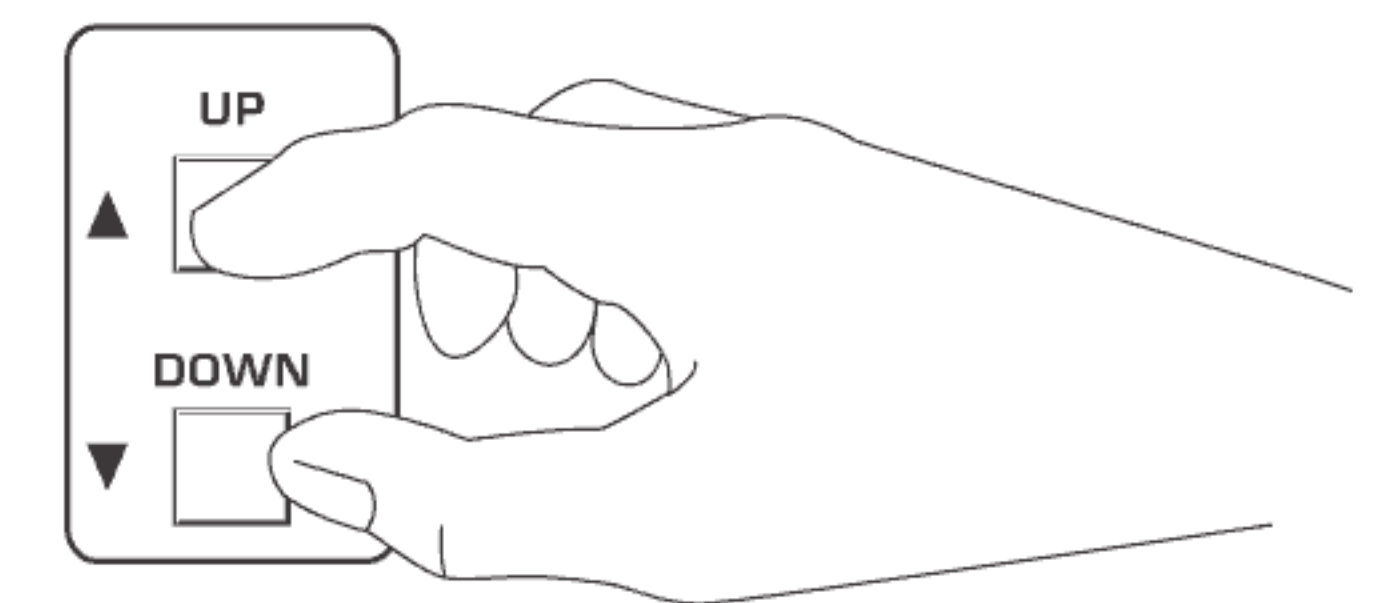
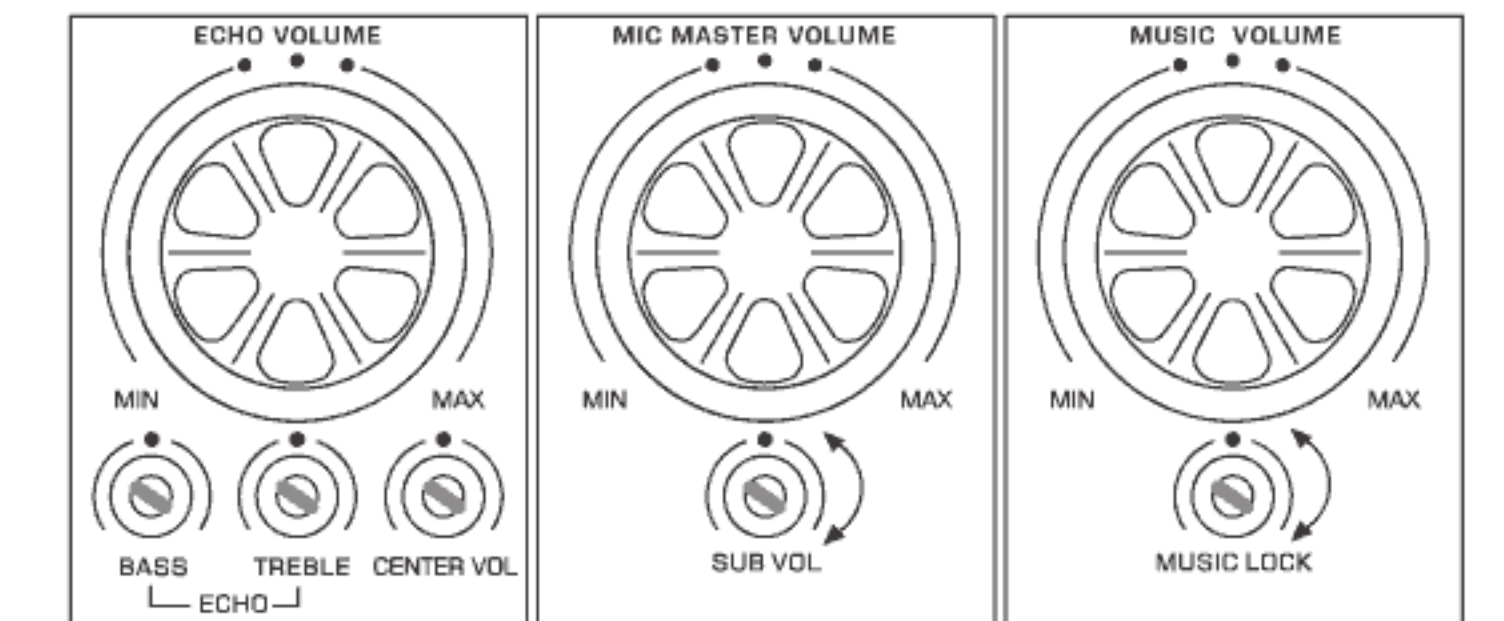

NOTE

You cannot set the memory for the start-up volume level for ECHO, MIC MASTER AND MUSIC VOLUME at the same time. It would not work.

KARAOKE ROOM

DX-222 is a five-channel Karaoke amplifier. The center out monitors the microphone vocal only for singing. No music comes out from the center out. Please refer to figure 2 for the best setup of the Group A and Group B speakers. To achieve the best Karaoke sound performance, we recommend you to use two different sizes of speakers for Group A and Group B. For example, the speaker of Group B uses a 5-inch woofer while the speaker of Group A uses a 10-inch woofer. This setup will be the most ideal for space (such as a room) with 1,000 to 2,000 square feet.

- A. Main Left Speaker (Group B)
- B. Main Left Speaker (Group A)
- C. Main Right Speaker (Group A)
- D. Karaoke Video Display
- E. Karaoke Video Display
- F. Wireless Microphone
- G. Monitor for Singer (Left)
- H. Karaoke Video Monitor for Singer
- I. Monitor for Singer (Right)
- J. Song Selection System
- K. Audio Equipment Rack

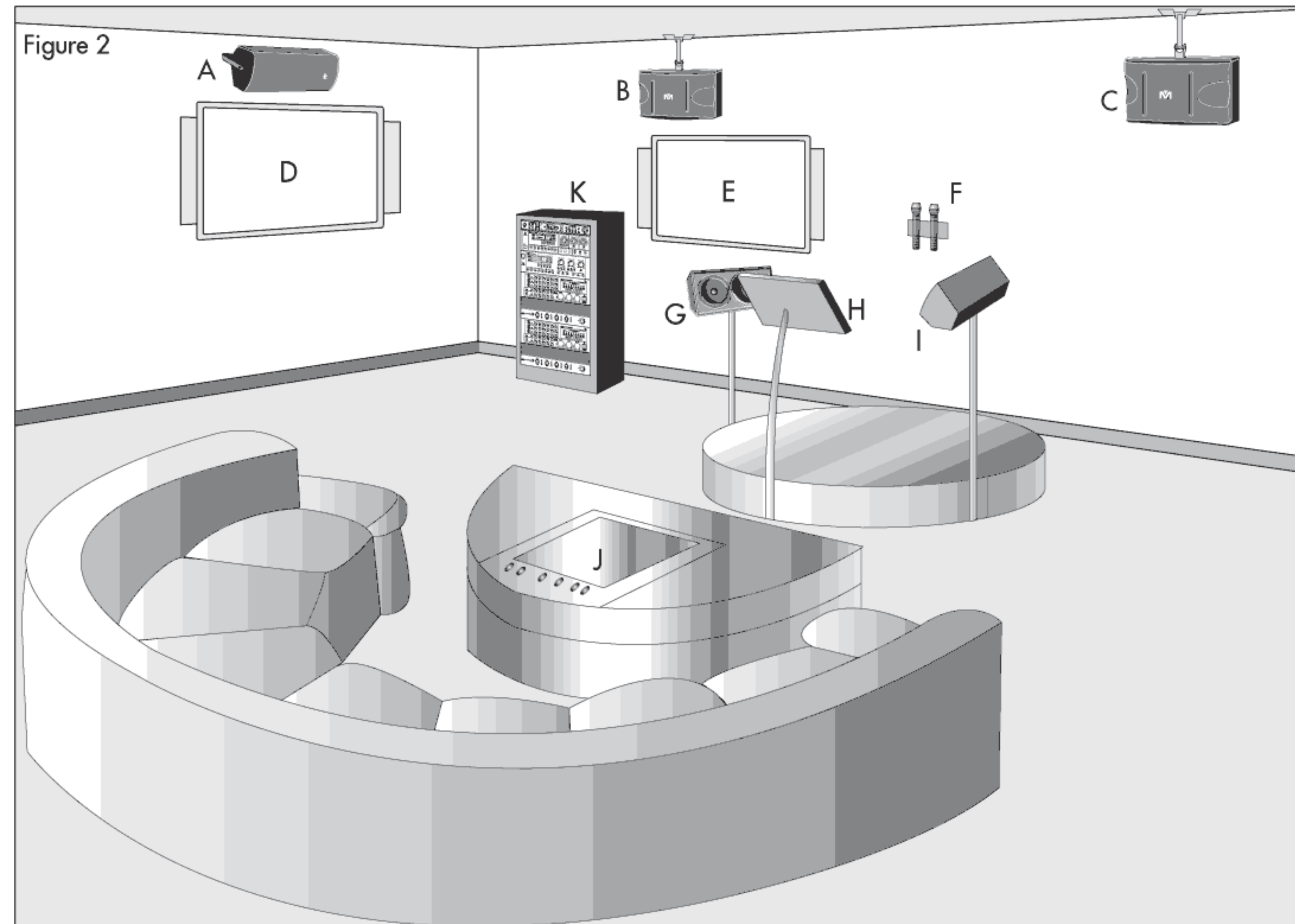
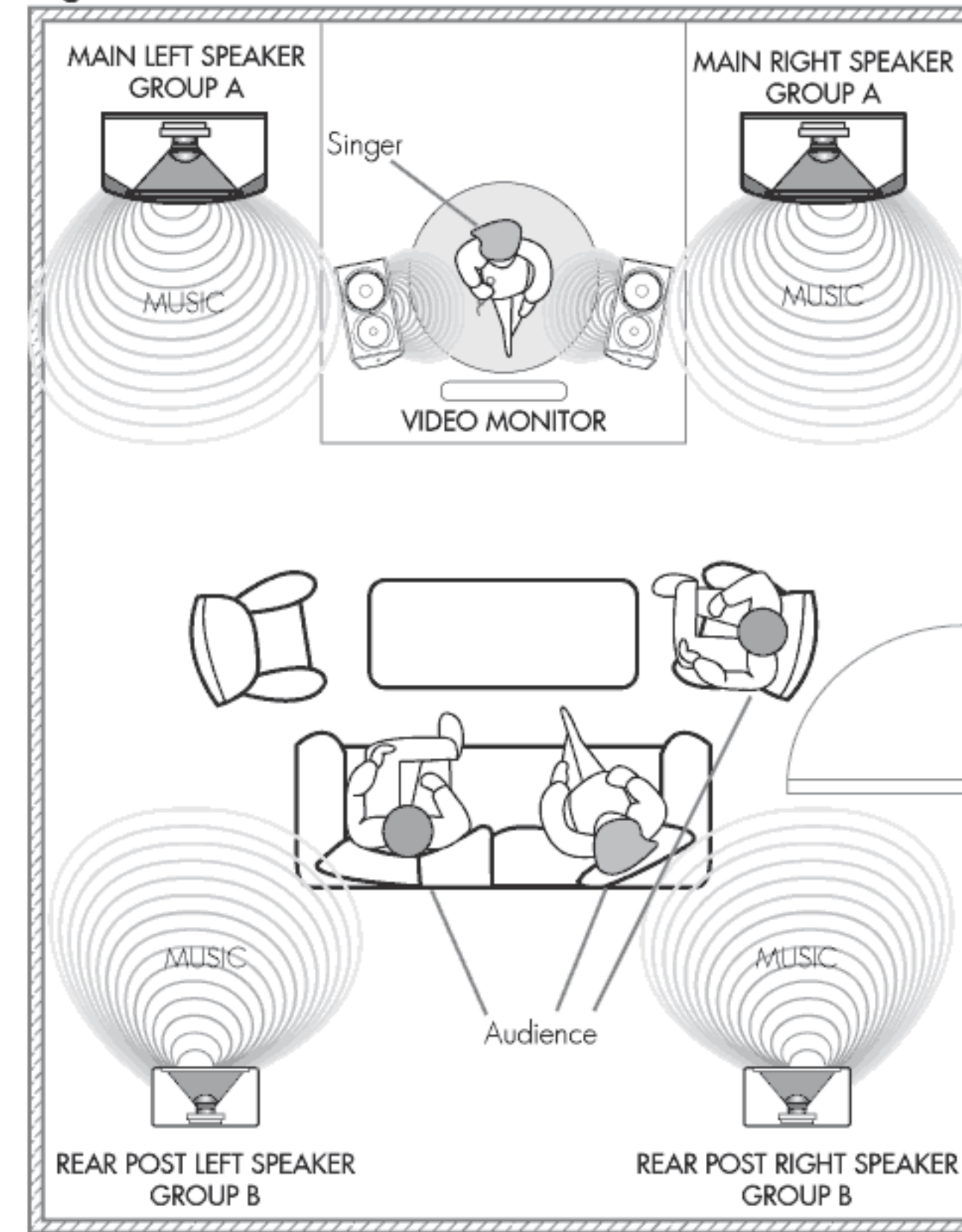

Figure 1



COMMERCIAL APPLICATION

The engineering team of Better Music Builder designed the DX-222, which is a CPU-controlled unit, specially for Karaoke commercial application (such as auditorium, restaurant, coffee shop, and hotel ballroom, etc.) to replace the traditional DJ equipment (such as 20-channel mixer, effect processor, key controller, 30-band equalizer and feedback destroyer, etc.) for Karaoke.

If you want to set up the DX-222 inside an auditorium or a commercial business of 2,000 square feet or more, we recommend you to use an external power amplifier for output. In this case, you connect the "Audio Out" of DX-222 to a power amplifier and a speaker system (with a 12-inch woofer) with power rating of at least 1,000 watts.

DX-222 REAR VIEW

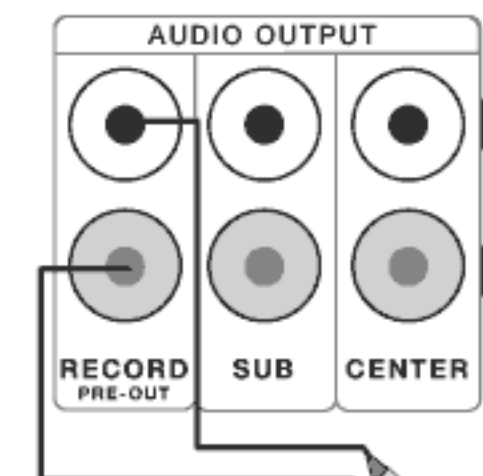

NOTE We recommend you to hire a professional technician to handle the installation for safety purpose.

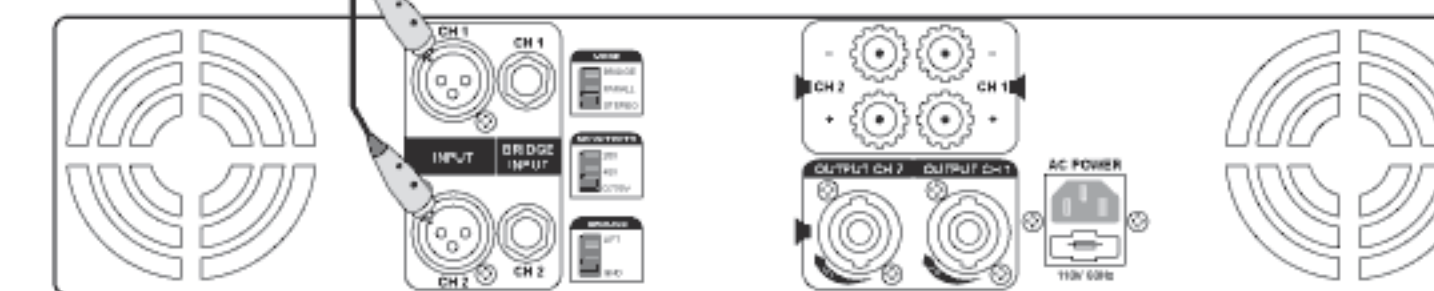

POWER AMPLIFIER REAR VIEW 1,000W.

Figure 3

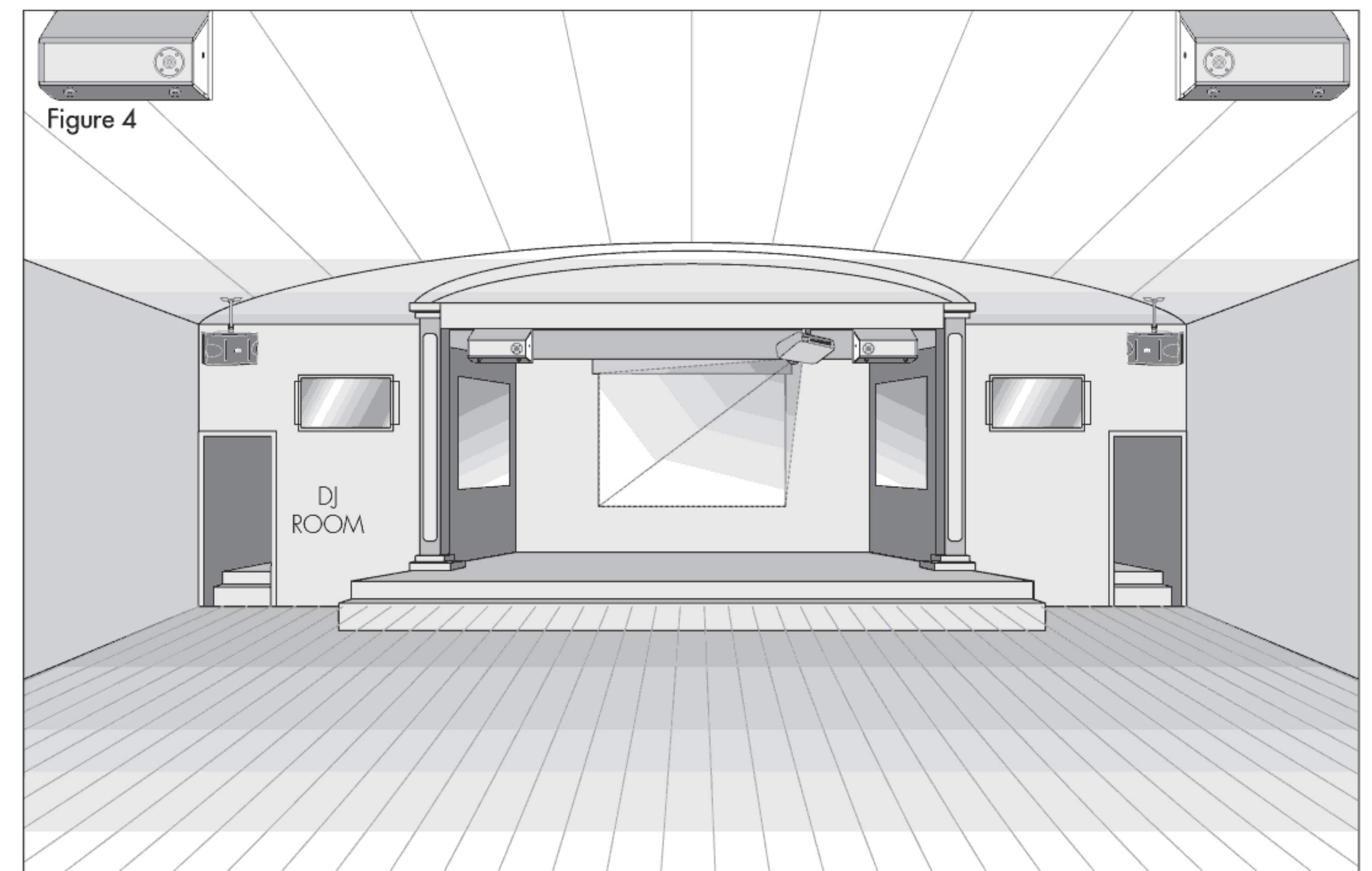
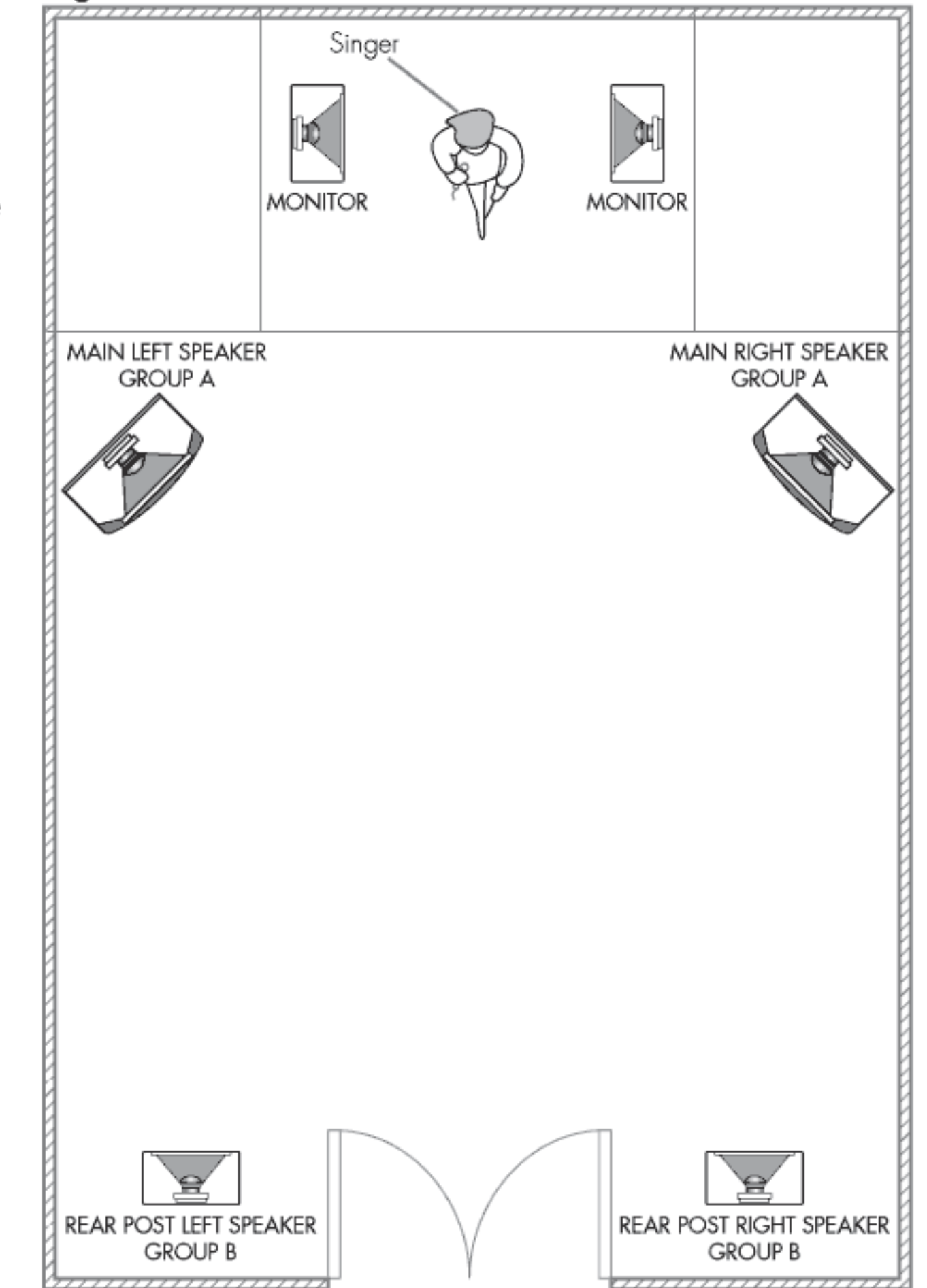

MONITOR OUT

DX-222 is designed with the ability to send signals to two different locations. For example, you can practice singing in a studio room without disturbing other people watching TV in the living room. To learn how to connect, please refer to page 30.

DX-222 can be set up in the recording room and you can practice singing in the studio. You do not need to use two mixing amplifiers with DX-222. All you need is one mixing amplifier (i.e. DX-222), a regular amplifier or powered-speaker(s).

Figure 5: Studio

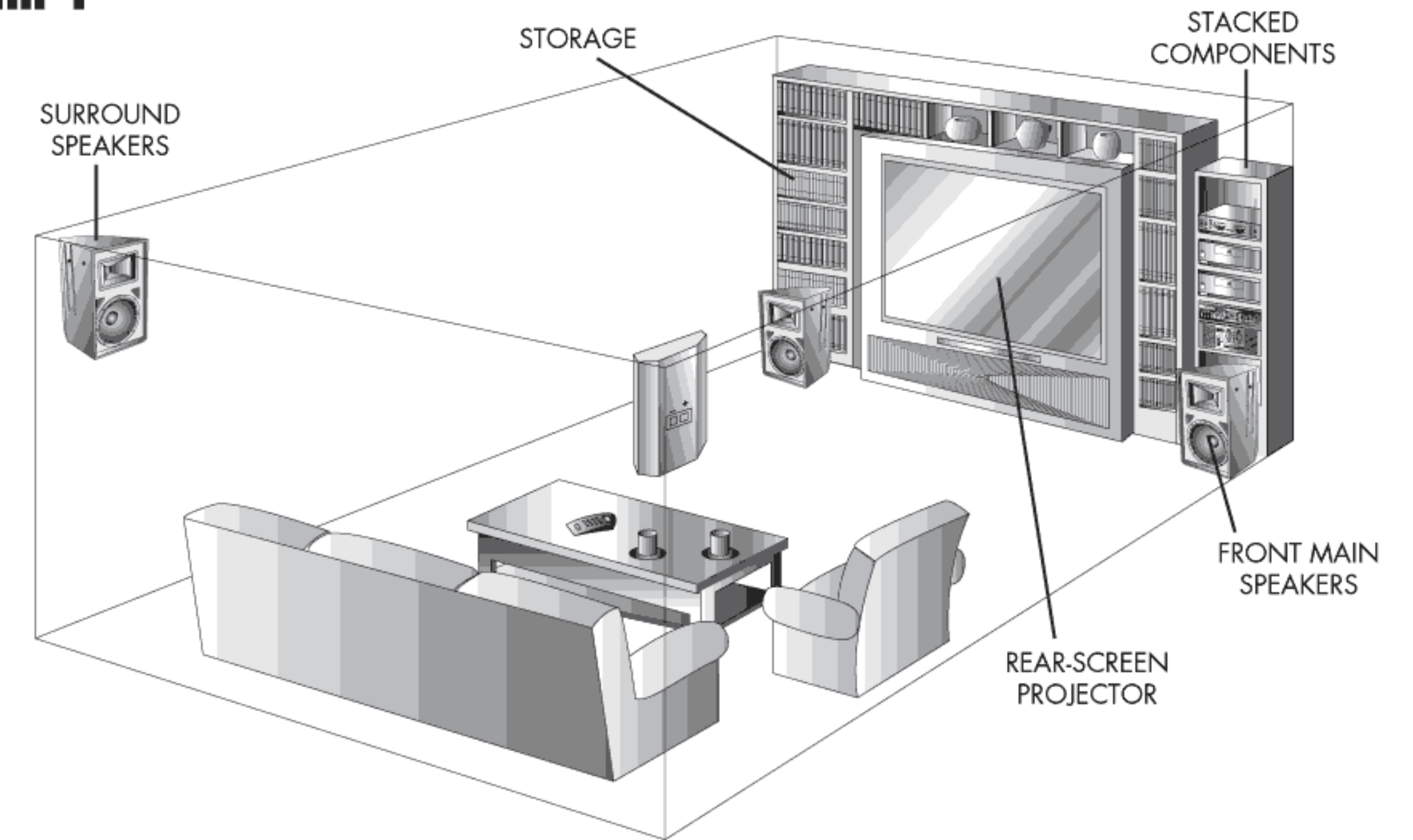

Figure 6: Recording Room



IDEAS FOR HOME THEATER AND KARAOKE

Diagram 1



The engineering team of Better Music Builder develops and provides you great ideas to satisfy your specific needs. For example, you can modify your bedroom or basement to become an entertainment place for home theater and Karaoke. You can invite your friends to your house for a great party. So, every family can feel the same atmosphere at home as in a nightclub or a theater at an affordable budget. This will bring you lots of fun at home. So, you may try to follow our great ideas for your own entertainment needs.

Diagram 2

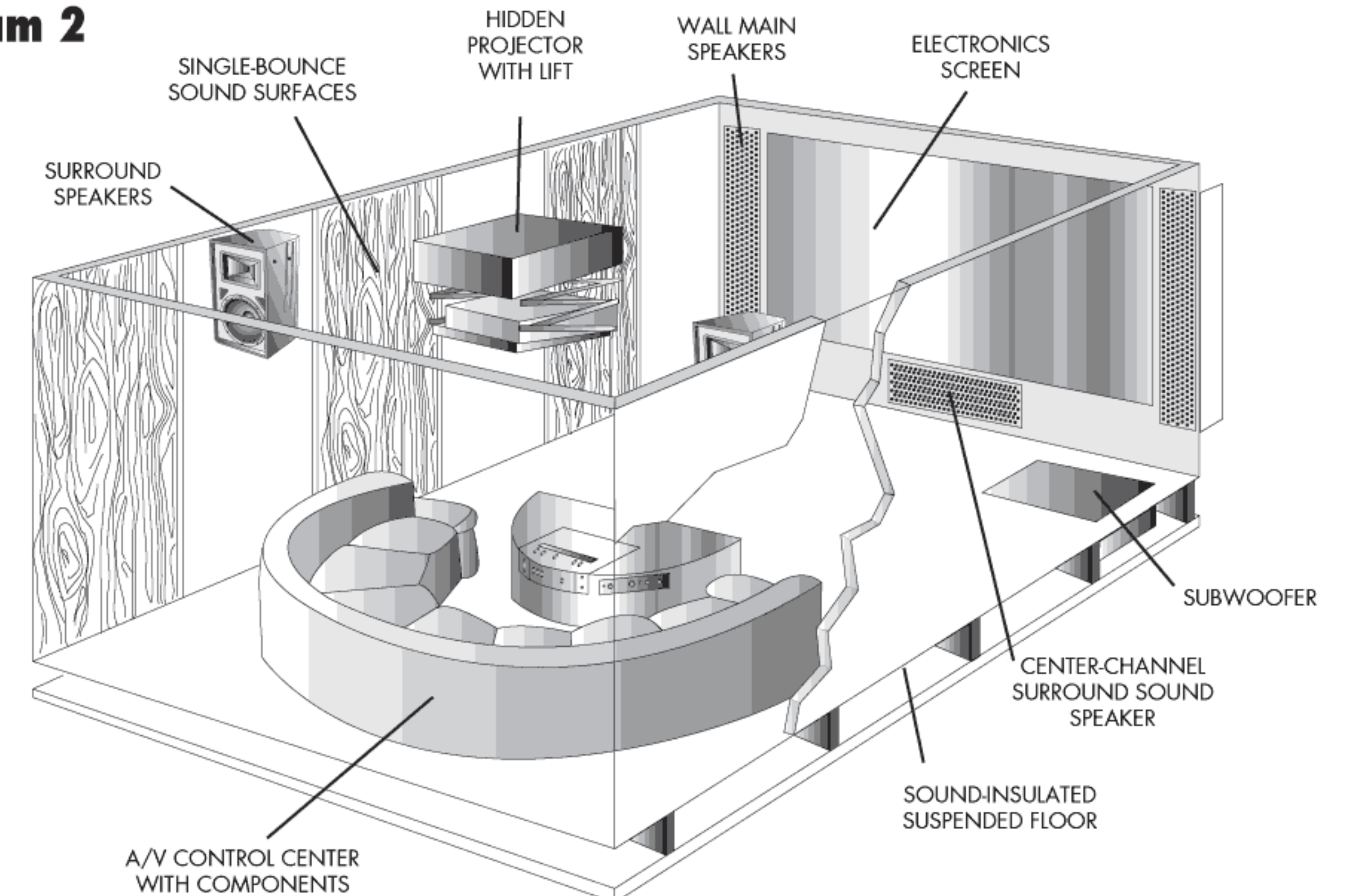

PRE-OUT

The DX-222 is versatile. It has three line audio level outputs for recording and connection to external power amplifiers to drive subwoofers and monitor speakers. This feature is useful because it's easy to expand.

For example, if you are having a party, you may have guests in the living room where the DX-222 and the main speakers are. At the same time, there are people in the backyard. That's when this feature comes in handy. You can run RCA lines to the back yard where power amplifiers can drive the subwoofer and monitor speakers, or you can hook up the RCA line to the powered speakers. Please note that we recommend you to use wireless microphones in the backyard for convenience. Please refer to page 18 under "Audio Output Record" for connection.

NOTE If the distance from the living room to the backyard is more than 25 feet, we recommend using an A/V distribution amplifier.

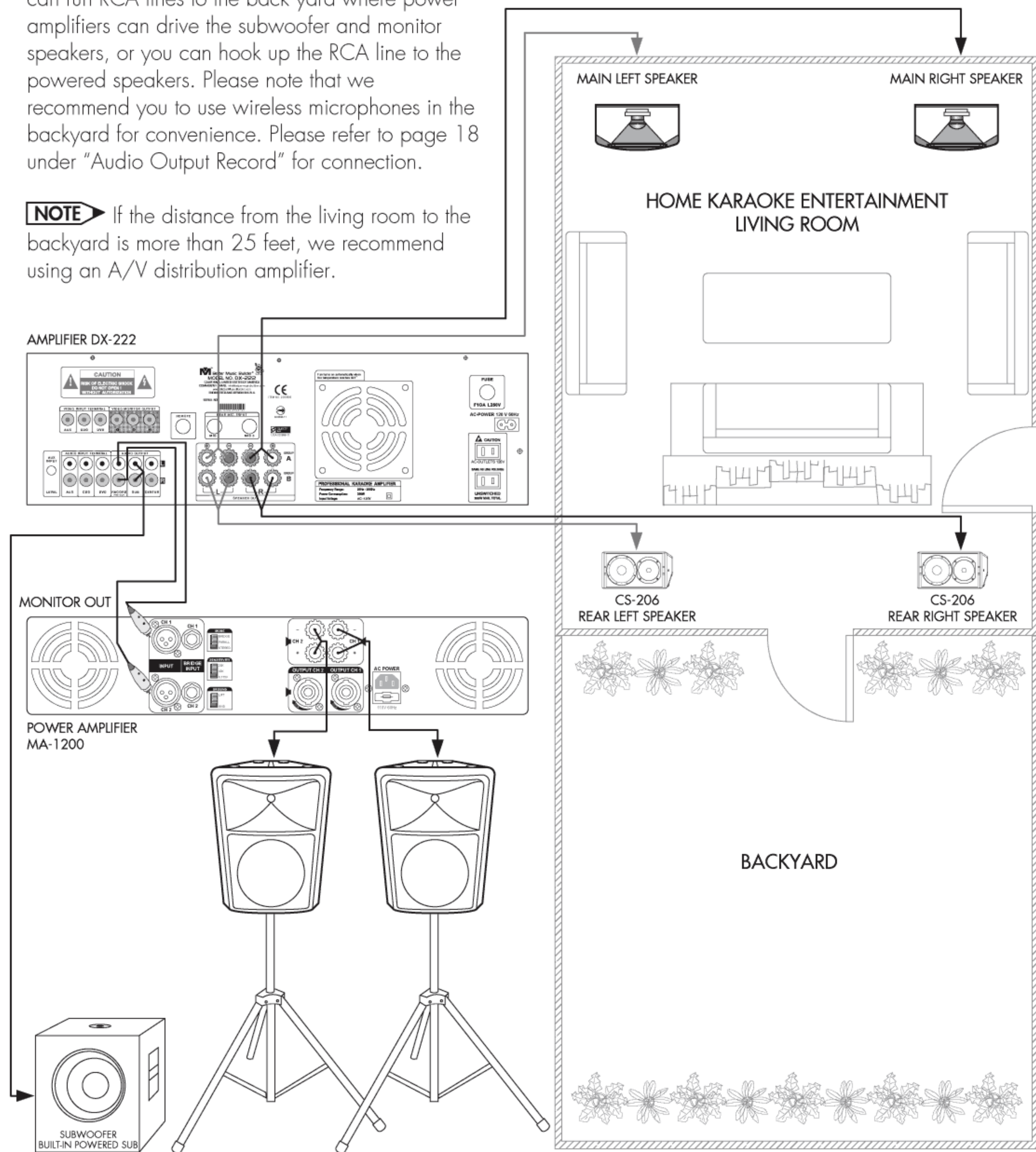

INSTALLATION SETUP

Through many years of experience in installation and design for Karaoke business in Asia, the engineering team of Better Music Builder has designed two installation setups as illustrated in figure 1 and figure 2 that can produce excellent sound performance. This design is specifically for North America.

DX-222 is a five-channel Karaoke mixing amplifier. The music comes from Group A and Group B speakers. You can mix the music and vocal together or by percentage (for example, 70% for music and 30% for vocal), and 100% original vocal comes from the center speaker. This setup can reduce the humming feedback to protect your audio equipment.

NOTE DX-222 with five-channel output would produce different effects from that of the 5.1, 7.1 and 7.2 home theater systems for playing movie.

In figure 1, Group A speakers are set up in the front and the Group B speakers are set up in the rear.

In figure 2, all speakers are positioned in parallel in the front. Therefore, we recommend using different size of speakers for Group A and Group B. The reason is that Group A has a bigger woofer (10-inch woofer or bigger) for music and Group B has a smaller woofer (6-inch woofer) for clear vocal. In addition, the vocal comes independently from the center monitoring speaker. Therefore, the audience can feel the better sound performance and unprecedented experience.

Figure 1

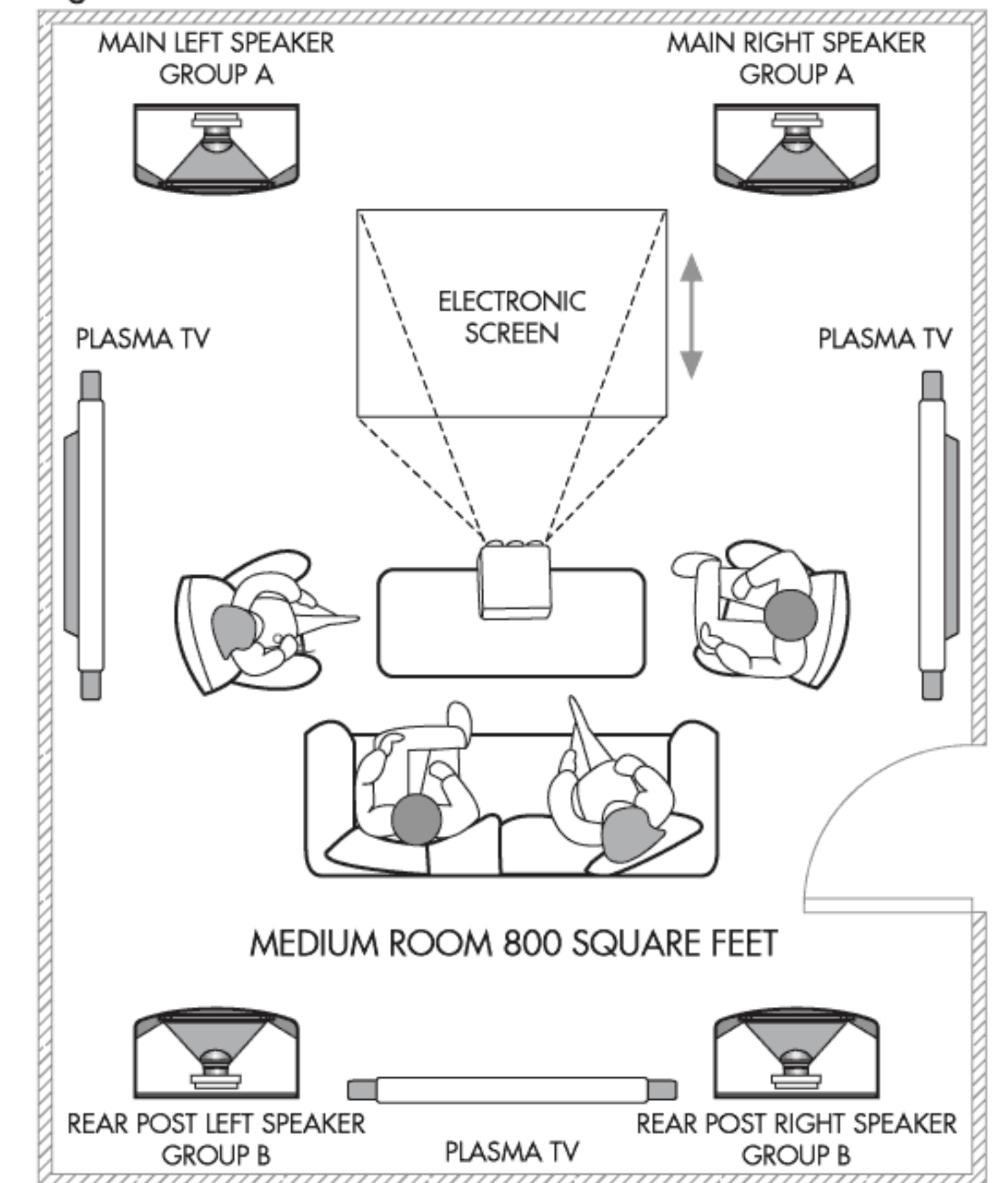
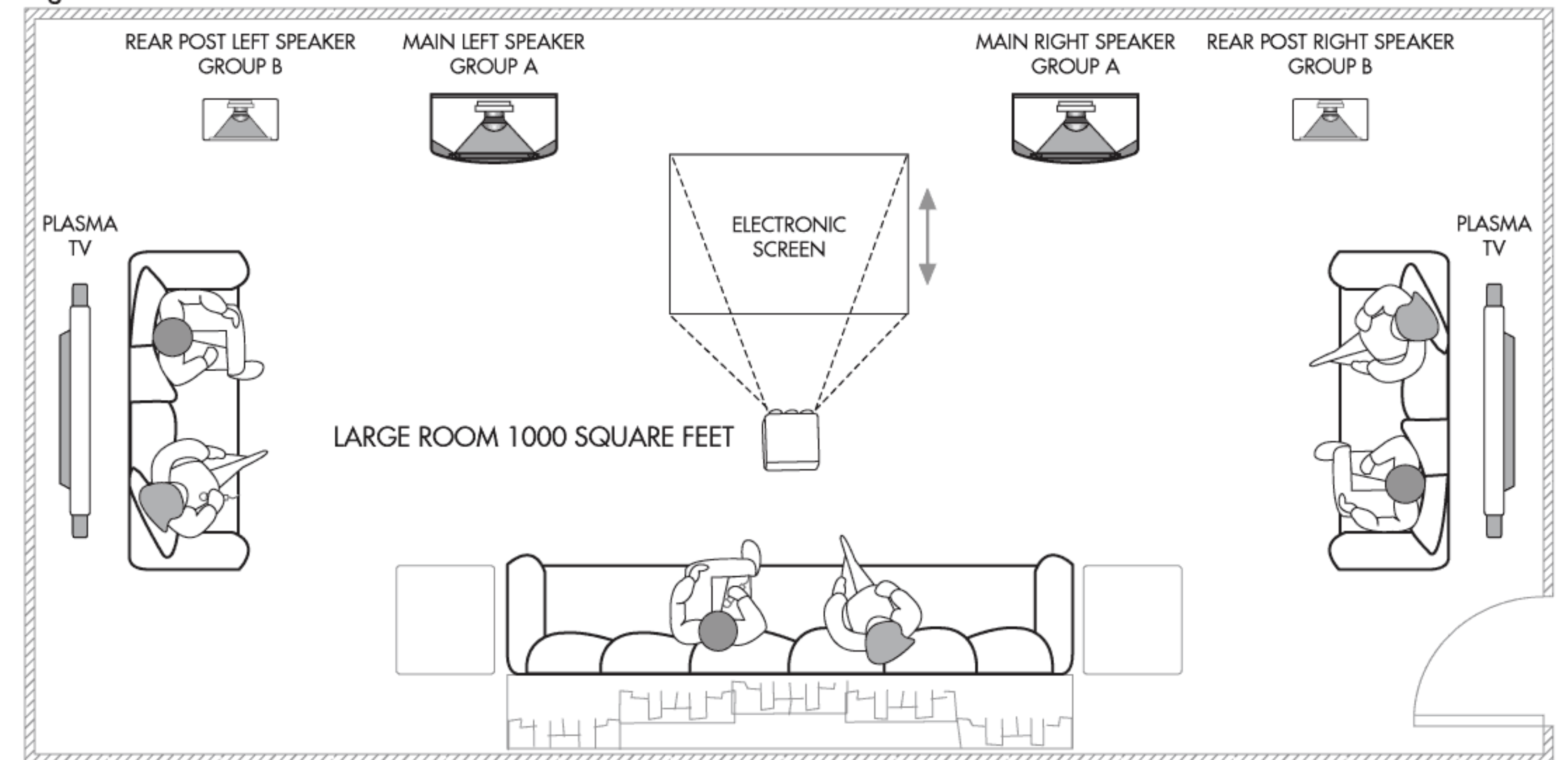

Figure 2



DVD CONNECTION FOR HOME

Better Music Builder Video-On-Demand (VOD) system is designed with the state-of-the-art technology by our in-house engineering team. This VOD system is loaded with a maximum of 8 hard drives (300 GB each) to allow plenty of memory space. Generally speaking, a personal computer has only 4 hard drives. Now you can load all your favorite video and audio discs (including VCD, CDG and DVD format), and your favorite Karaoke songs (in different languages as well) into this VOD system. Therefore, you would not worry about satisfying the various entertainment needs of your guests. You can certainly meet their expectations with this system.

Our Better Music Builder VOD system is also a great place to store memories of pictures for kids, parties and trips, etc. Because of the direct built-in TV feature, this system enables the presentation of slideshow for any pictures like kid's birthdays, parties, trips, banquets, functions, events and festivities, etc. By using our Better Music Builder VOD system, you can say goodbye to your dusty photo albums and bulky video cassettes. You can also organize your video and audio discs easily and retrieve the information electronically. Now you can save a lifetime of your cherishable memories with this VOD system.

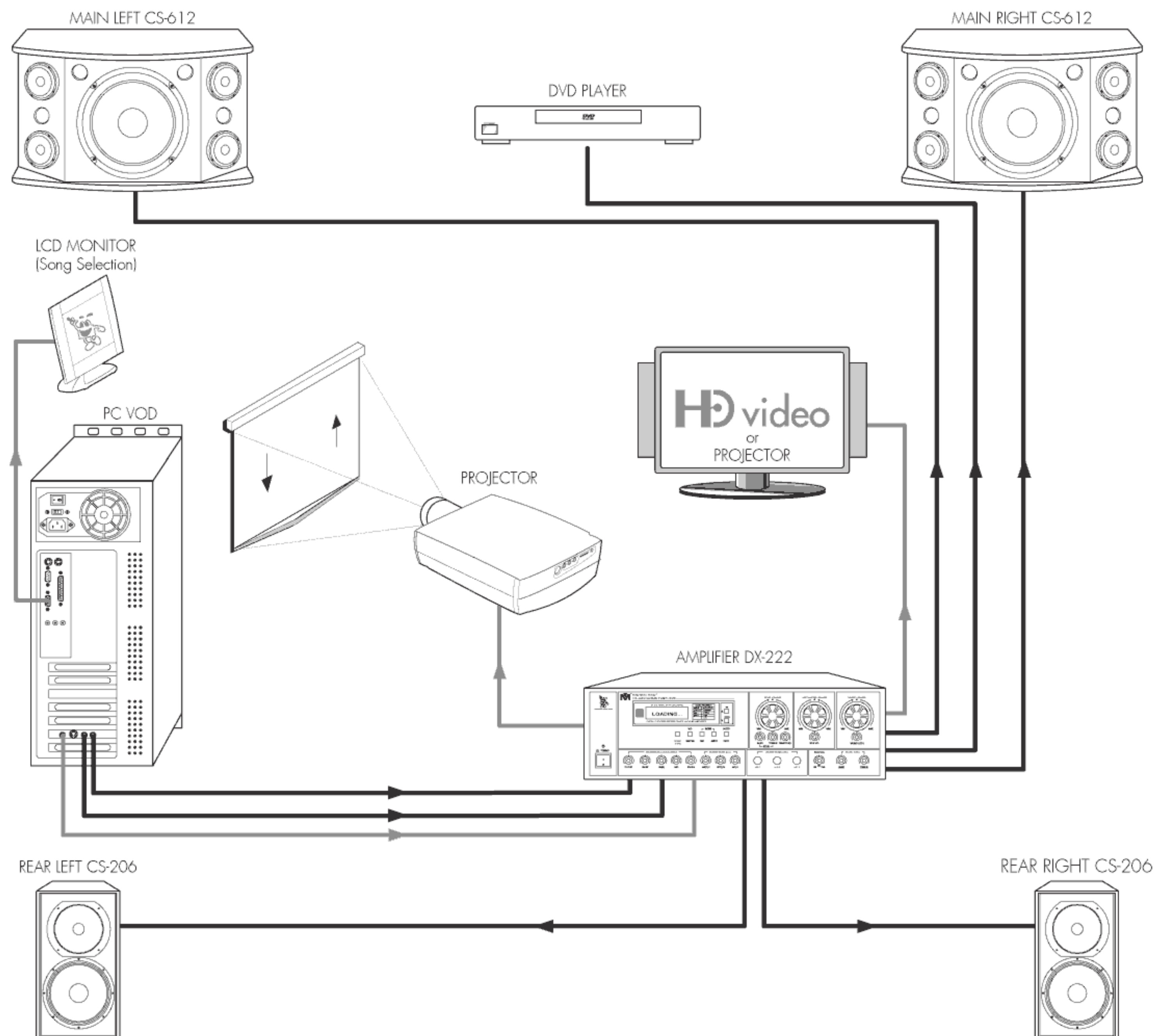

DVD CONNECTION FOR COMMERCIAL

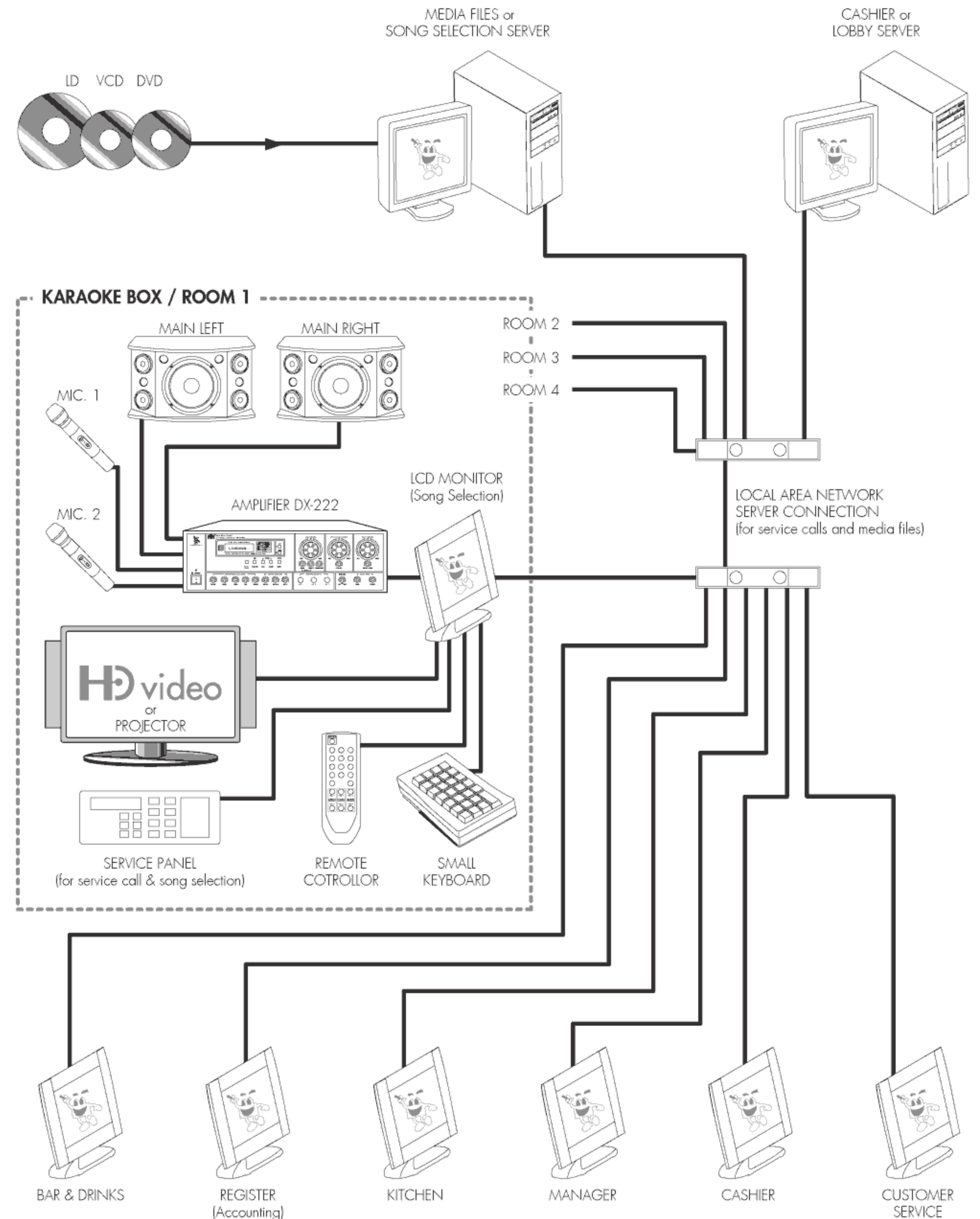

SIGNAL FLOW

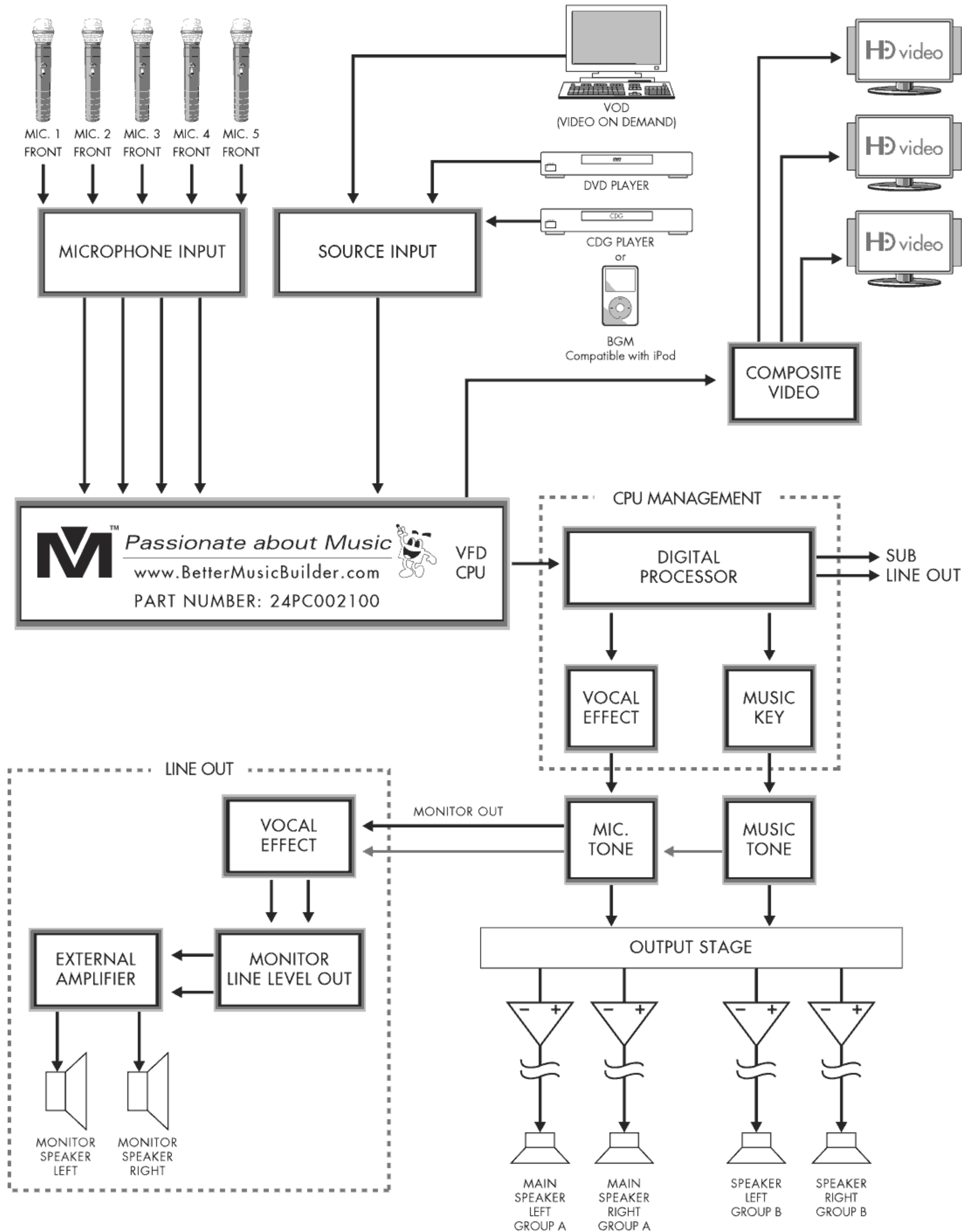

TROUBLESHOOTING

1. Echo Volume Malfunction

Symptom: Echo volume can not be changed.
Possible cause: MIC EFFECT mode is in FIX mode.
Remedy: select MIC EFFECT mode other than "FIX." The "FIX" is used to lock your favorite microphone effect setting.

2. Low Power Output

Symptom: the music power output is too low even with the MUSIC VOLUME knob turned all the way up to maximum.
Probable cause: "Music Lock" is adjusted too low.
Remedy: refer to page 24 under topic 20 "Music Lock" to re-adjust the "MUSIC VOL LOCK".

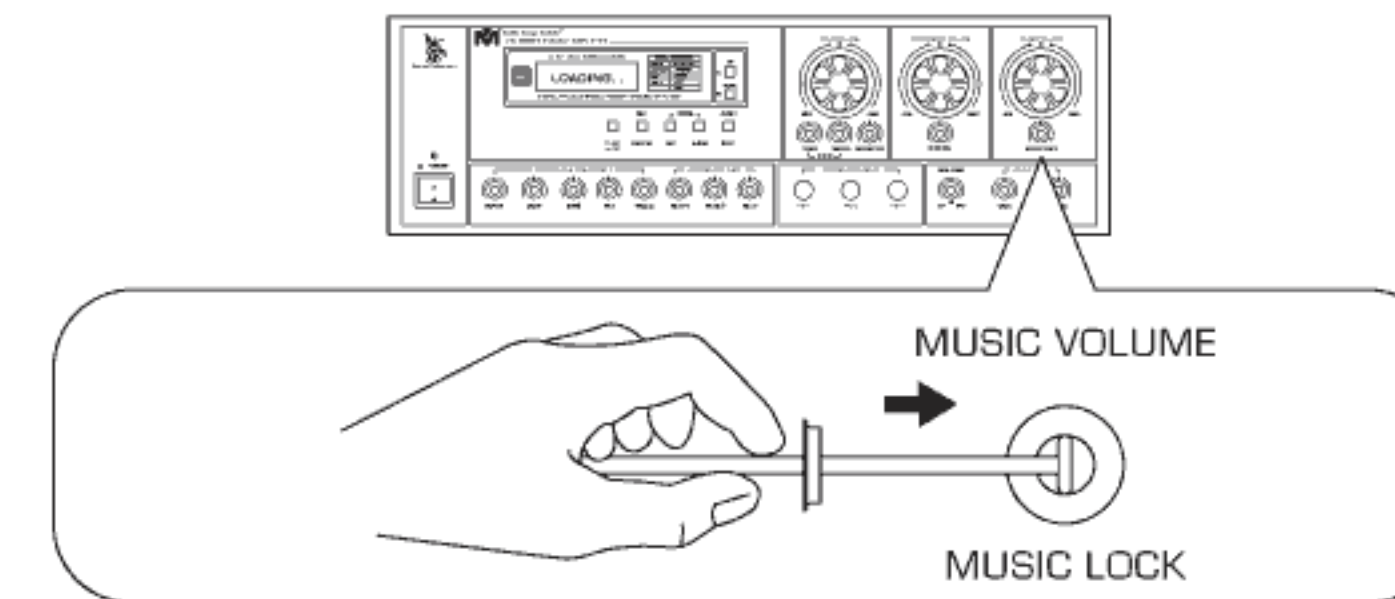

3. Microphone Adjustment Frozen

Symptom: MIC EFFECT MODE, ECHO VOLUME and MIC MASTER VOLUME can not be changed.
Probable cause: MIC VOL LOCK is on.
Remedy: refer to page 23 under topic 8 "Mic Volume Lock" to turn off the lock.

4. Starting volume level too high

Symptom: when the machine is turned on, the starting volume (i.e. music, microphone and echo) is too high.
Remedy: refer to page 25 under topic 23 "Setting the Memory for Your Favorite Volume Level" to reset the starting volume level.

5. Input Select: CDG

Symptom: When you try to select CDG, it automatically jumps back to DVD.
Probable cause: DVD is in use.
Remedy: refer to page 22 under topic 4 "AUDIO INPUT." Another alternative is to disconnect the equipment at the DVD connection and connect your CDG directly to the DVD input.

NOTE

DVD has the first priority for source input selection.

6. Video Problem

Symptoms: The video display appears in black and white color only or it has unstable image.

Possible Causes:

1. Video source (i.e. DVD player) is in different formats like NTSC or PAL. Therefore, you should select the right "Video Format" in the "Output" of the DVD player. It is because the video display is incompatible with the video source.

2. The video out from the amplifier to the video display has a distance over 25 feet. Therefore, you should use a signal distribution amplifier to enhance the signals.

3. You may be using the wrong cable for connection. The cable for video signal is different from the cable for audio, microphone and speaker. Therefore, you should use coaxial cable for connection.

4. You may be using a low quality cable with poor connection. We highly recommend you using high quality audio/video cable for connection. Please refer to page 37 for high quality cable.

7. Amplifier Shut Down

Symptom: the amplifier automatically shut down when playing at high volume.
Probable cause: you are using a wrong AC power cord that is thinner than our supplied cord.
Remedy: only use the AC power cord supplied with the unit by our manufacturer or equivalent. See illustration below.

8. Protection for Audio/Video Equipment

Before you hook up or disconnect any audio/video equipment, you must turn off the power for all equipment for connection. Otherwise, it may cause black spots to appear in the Plasma (or LCD) TV screen.

9. Sound Problem

Symptom: No sound.

Possible Cause:

1. Speaker wires positive and negative touch each other at the terminals. We recommend you using the double banana plug. Please refer to page 12.

2. "Mute" is on.

3. "MUSIC LOCK" is on with music volume limit adjusted too low. Please refer to page 24 under topic "20. MUSIC LOCK".

PHYSICAL

Height	6 inches / 15 cm
Width	17 inches / 43.2 cm
Depth	15 inches / 38 cm
Net Weight	28 LBs / 12.7 kg

Front view

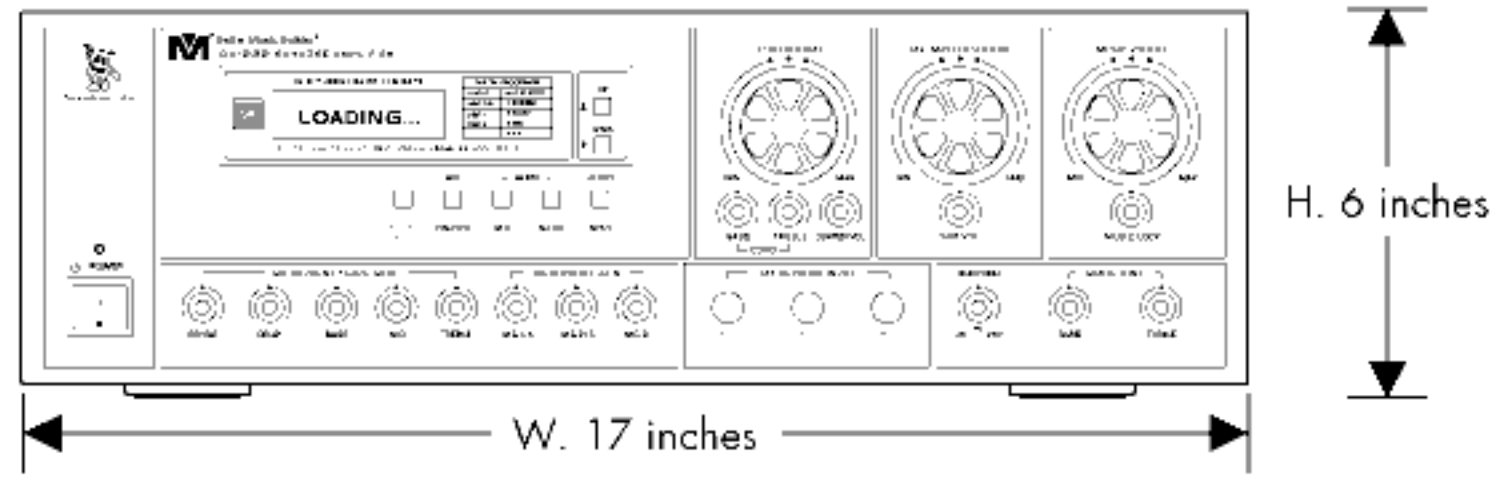

Side view

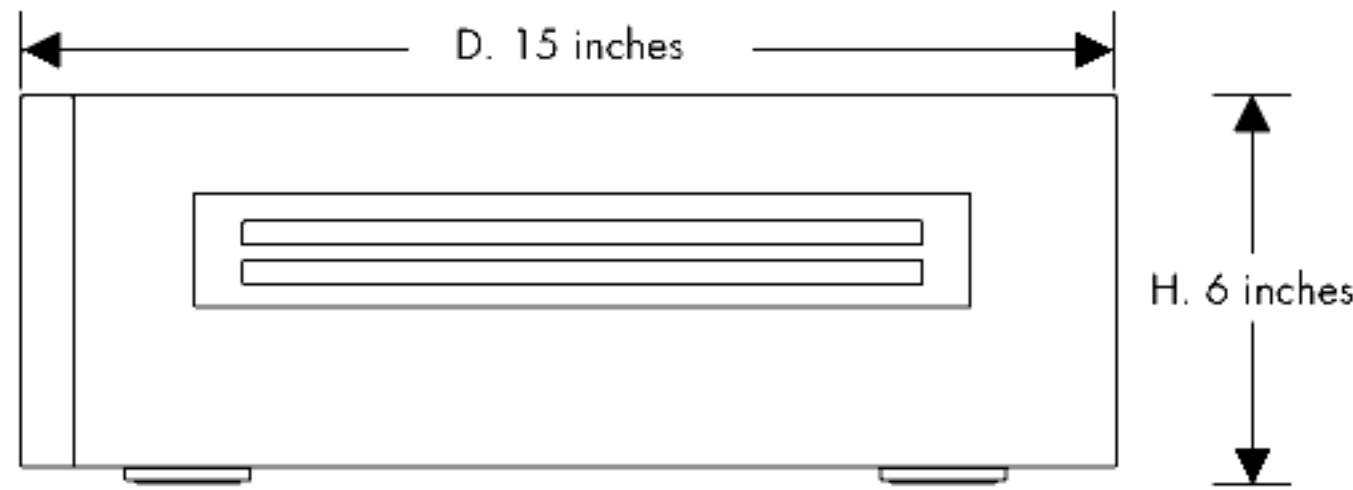

Top view

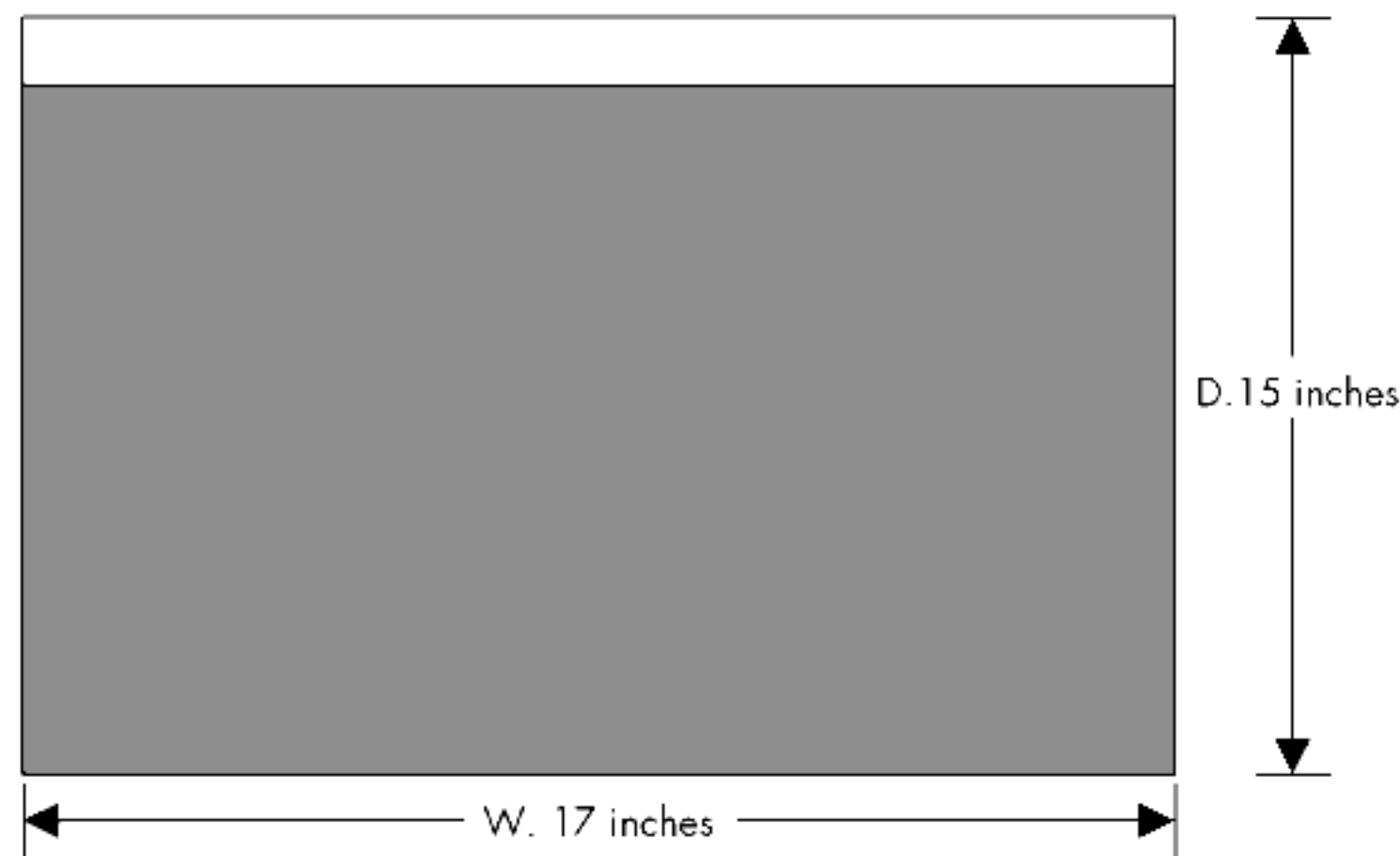

Optional for 19" rack mount kit

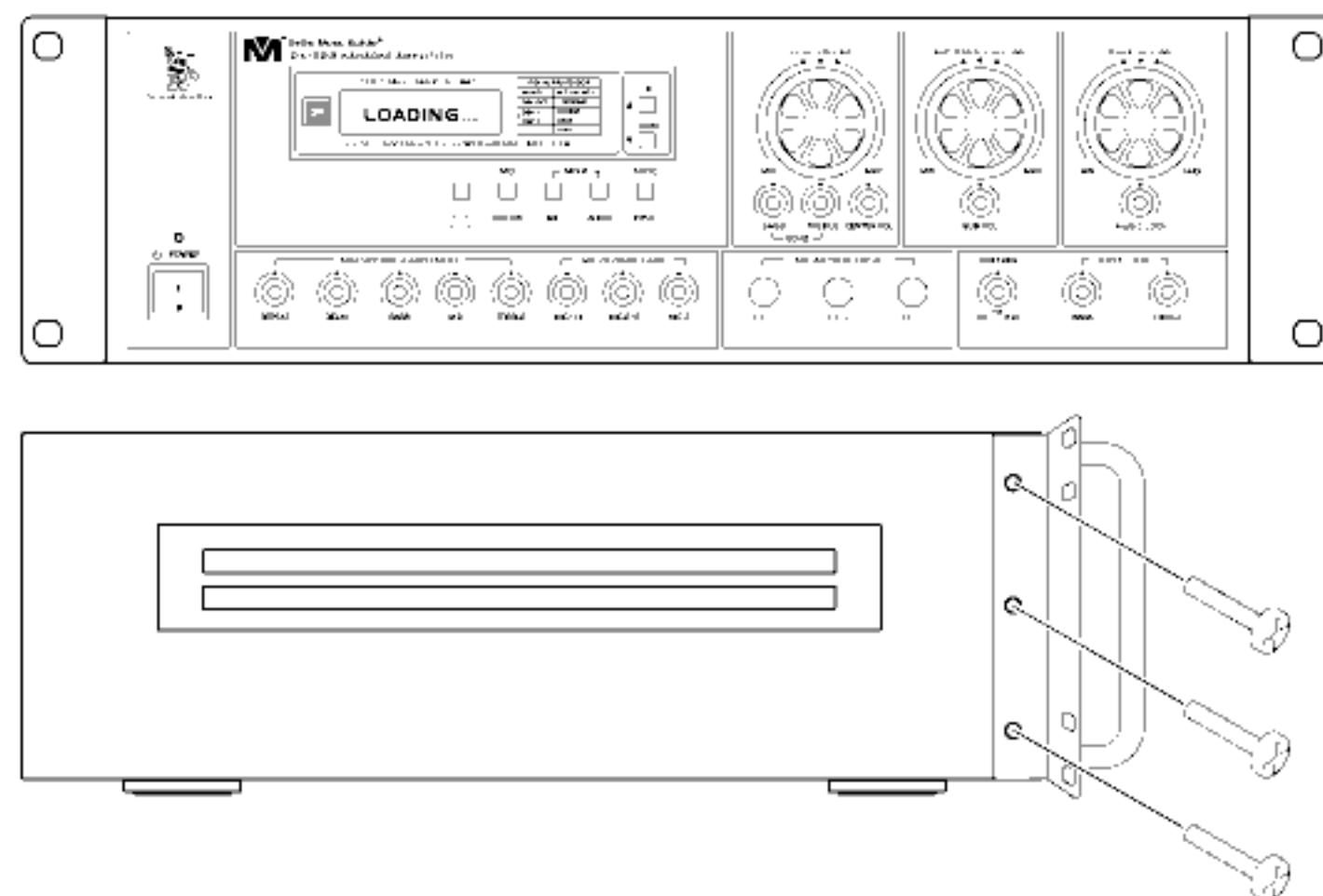

The standard kit is optional. Please make sure that you get the right kit for the size you want. Then, you can put the amplifier into the rack. The rack is used to protect the amplifier. If you have such portable equipment, you can have party at home anytime or use it for Karaoke rental business.

The Bracket/Handler in figure 1 is used to hold your audio/video equipment firmly in place, but not for transportation. If you need to transport the equipment, we recommend you using the heavy duty clamping rack shelf (optional) as illustrated in figure 2. You should place the heavy duty clamping rack shelf into the portable case. This would protect your equipment. There are different sizes of the heavy duty clamping rack shelves to suit your specific needs. Please note that the bracket/handler, rack shelf and case are not included in the package. They are optional items and sold separately.

Amplifier Front Bracket/Handler for 19" Rack

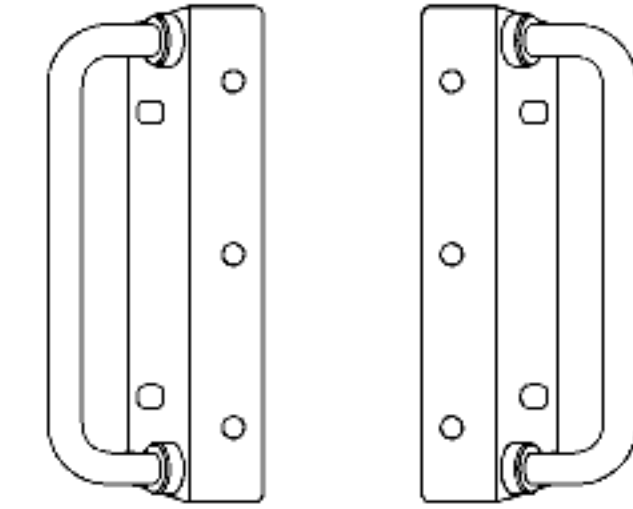

Figure 1

heavy duty clamping rack shelf

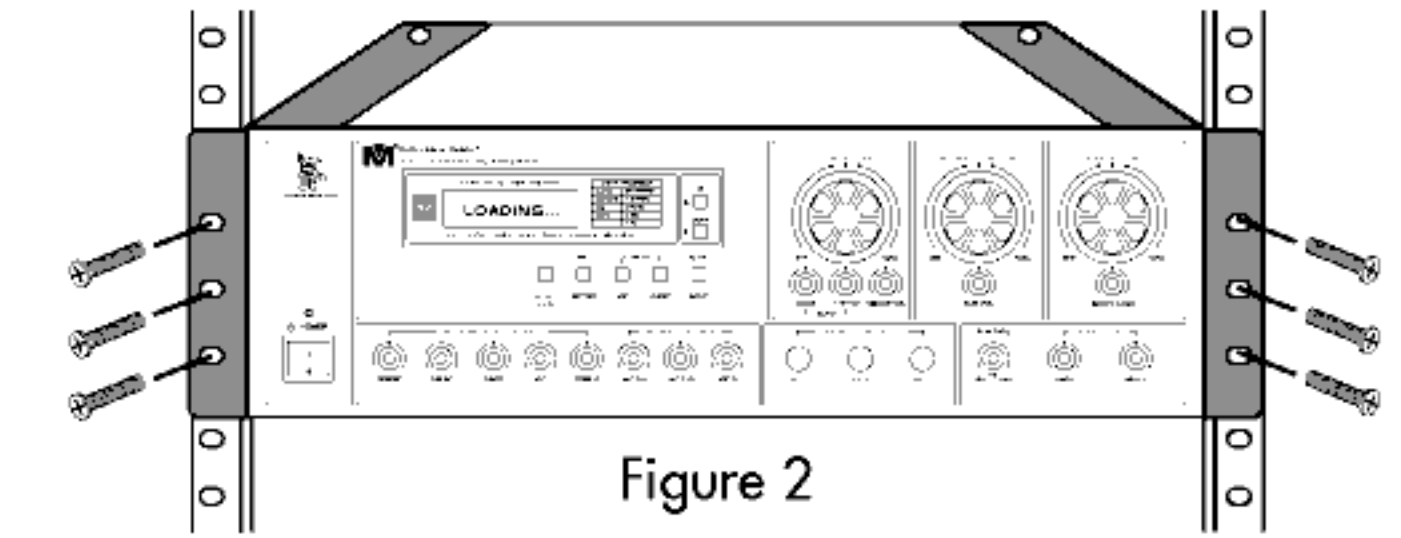
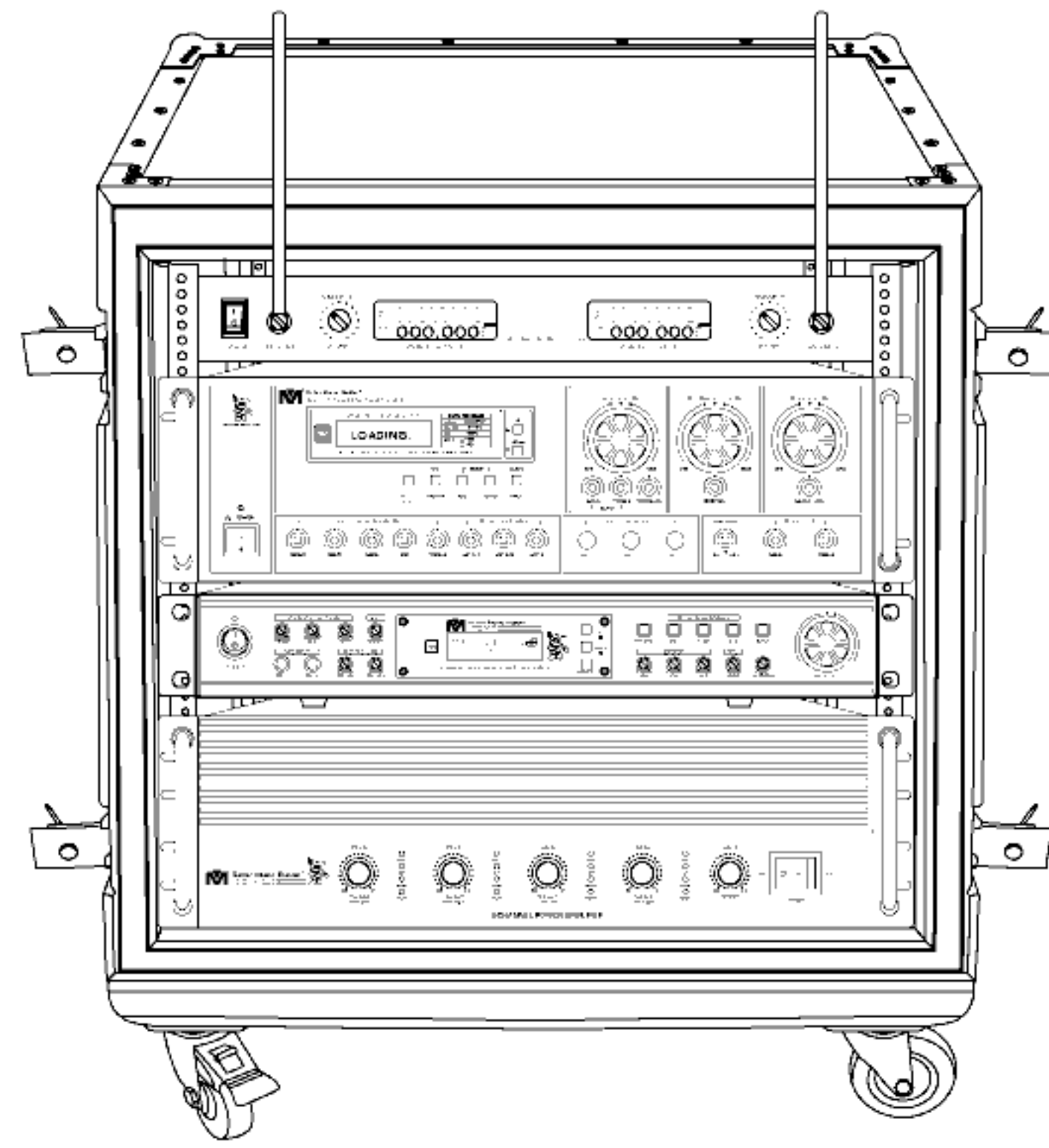

Figure 2



FINAL WORDS TO USER

The engineering team of Better Music Builder has many years of experience in audio equipment design. The team constantly develops new audio technologies, designs innovative audio and Karaoke equipment to suit your specific needs and provides you great ideas for home entertainment. For example, we offer you the great idea to modify your bedroom or basement to become an entertainment place for home theater and Karaoke, so you can have great party with your friends at home.

Our engineering team also designs audio equipment for commercial use by restaurants, coffee shops, churches, and school auditoriums, etc. If the commercial area for audio equipment installation exceeds 2,000 square feet, we highly recommend you to hire audio professionals to handle the installation for you in order to avoid risks in breaking the equipment with improper installation and protecting your own safety.

We also provide you free education and technical information on audio equipment and technologies. For example, we provide free installation diagrams to make it easier for you to connect the system. In addition, to get best connections for the sharpest image and good sound quality, we give you the hot tip for choosing the high quality type of A/V cable for connections. You can download the free information on audio equipment and technologies from our website www.BetterMusicBuilder.com.



HIGH QUALITY A/V CABLE FOR CONNECTION

POOR QUALITY CABLE



AUDIO RCA CABLE

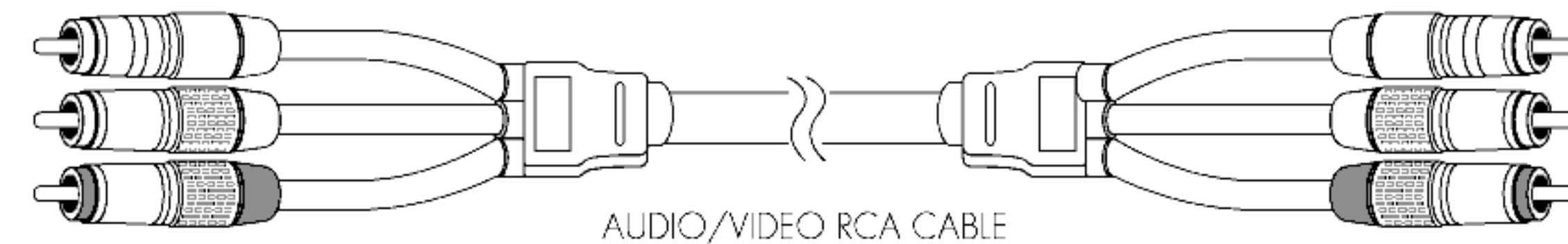

AUDIO/VIDEO RCA CABLE

Please do not remove the "Yellow Label" in the rear of your machine, otherwise, the warranty will become void automatically. We design it to protect your own safety. If you need repair and maintenance service, you may contact us directly or hire a professional technician to repair your machine. To learn more about the technical aspects, you can visit our website www.BetterMusicBuilder.com and download the relevant information for review.



Any form of tampering with this product, will void the warranty.

NOTE

Before you hook up the system, you must turn off the AC powers on all machines including audio/video equipment and TV. Otherwise, it may damage your equipment, especially on the HDTV in which a spot appeared in the TV screen. After you have hooked up the system, you must double check the audio/video connections to ensure that they are connected correctly.

Sometimes the cable of poor quality would affect the microphone effects, picture quality, or even cause the machine to shut down suddenly.

Again, we must thank you for choosing Better Music Builder product. We hope you can make the best use of the machine and enjoy it for fun. If you have any questions regarding your machine, please feel free to contact us at www.BetterMusicBuilder.com.

WARRANTY

One-year Limited Warranty for Home Use Equipment

Our one-year warranty applies to speakers, amplifiers, mixers and microphones for home use only. It covers both parts and labors. The warranty becomes effective from the date of your purchase for one year.

Our warranty only covers defects due to product defectiveness with free of defects in materials or workmanship. However, our warranty does not cover defects due to normal wears, damage in transit, improper use, abuse or failure to follow the proper instructions for maintenance. This warranty is void in the event of unauthorized repairs, alternations, modifications and removing of the product label.

Please also note that our warranty does not cover any shipping cost for the return of defective products to us for inspection, repair and maintenance. Our warranty for Better Music Builder products can only be executed in North America.

NOTE Our warranty does not cover the battery for wireless remote control.

90-day Limited Warranty for Public and Commercial Use Equipment

Our 90-day warranty applies to speakers, amplifiers, mixers and microphones for both public and commercial use such as restaurant, coffee shop, KTV nightclub, church and school, etc. It covers both parts and labors. The warranty becomes effective from the date of your purchase for 90 days.

Our warranty only covers defects due to product defectiveness with free of defects in materials or workmanship. However, our warranty does not cover defects due to normal wears, damage in transit, improper use, abuse or failure to follow the proper instructions for maintenance. This warranty is void in the event of unauthorized repairs, alternations, modifications and removing of the product label.

Please also note that our warranty does not cover any shipping cost for the return of defective products to us for inspection, repair and maintenance. Our warranty for Better Music Builder products can only be executed in North America.

NOTE Our warranty does not cover the battery for wireless remote control.

To Register Your Warranty

Please fill out the warranty card that came with your unit, download or submit online warranty form. However, we need the invoice for your purchase in order to process this warranty. You may also register your warranty online.

Please visit our website at www.bettermusicbuilder.com.

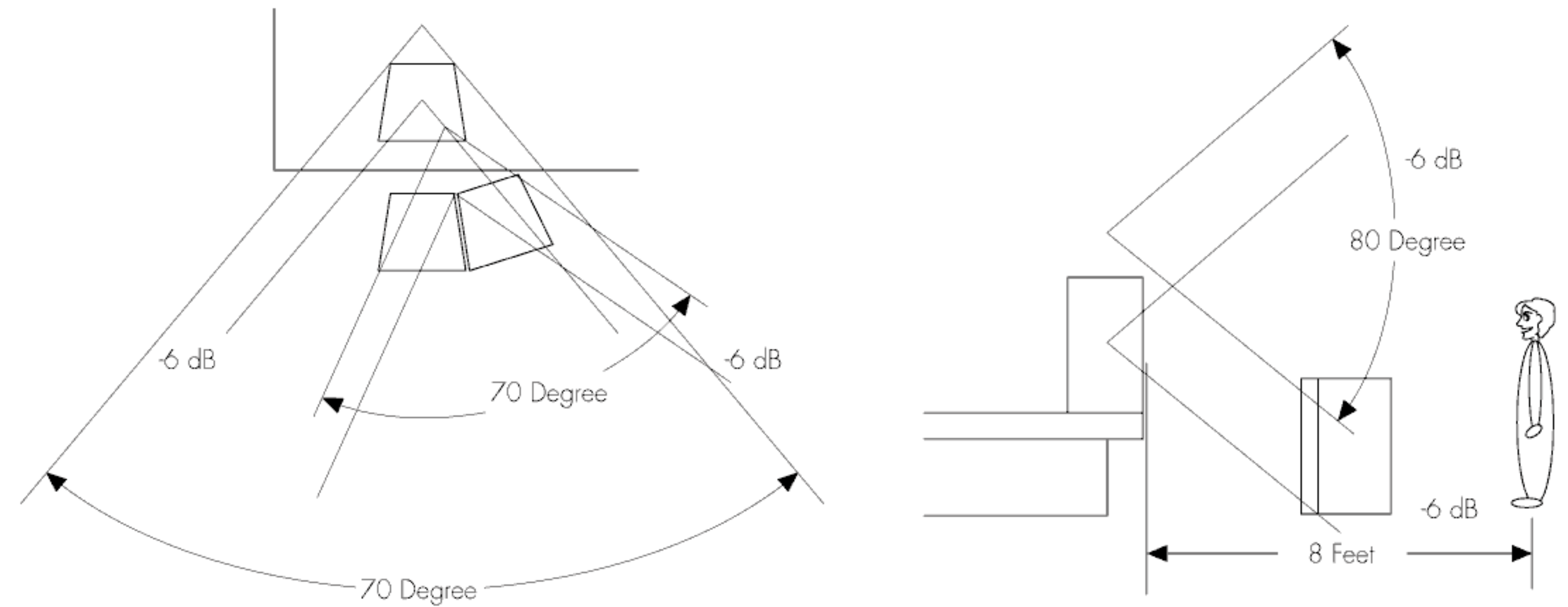

MAINTENANCE

With proper maintenance and regular service, it would maintain the machine quality and prolong its life. We recommend you to print the following information clearly for future reference on maintenance and warranty.

MODEL# _____ DATE PURCHASED (MM/DD/YYYY) _____

DEALER NAME _____ CITY _____ ST./PROV. _____ ZIP/P.C. _____

DEALER WEBSITE <http://www.> _____ INVOICE # _____

DEALER PHONE # _____ DEALER E-MAIL _____

NOTE

In the following space, you can write notes on symptoms and potential problems of your machine, dates of noticing machine defectiveness, maintenance service and information on your warranty, etc. and anything you want to write regarding the maintenance on your machine.



Passionate about Music
www.BetterMusicBuilder.com