



OWNER'S MANUAL (Version II)

Better Music Builder is a leader in the Audio and Karaoke equipment industry. We are committed to offering you the high quality audio product. We may update our manual, so we highly recommend you to download the free update from our website www.BetterMusicBuilder.com.

CPU Audio Video Effects Processor

DX-3000



Thank you for purchasing this unit. To make full and effective use of this unit, please read this Owner's Manual carefully before operating it. Please retain this manual for future reference.

Passionate about Music
www.BetterMusicBuilder.com

We will not notify you any errors or changes in this manual in advance. If there are any errors and changes in this manual, we will make the corrections in a timely manner. The corrections and changes will be appeared in our website. Therefore, please visit our website www.BetterMusicBuilder.com frequently to find out the most updated information, corrections on errors and changes in this manual. You may also contact us at toll free at 1-800-318-2218.



SAFETY INSTRUCTIONS

1. Read Instructions: All the safety and operation instructions should be read before this product is operated.
2. Retain Instructions: The safety and operating instructions should be kept for future reference.
3. Warnings: All warnings on this product in these operating instructions should be followed.
4. Follow Instructions: All operating and other instructions should be followed carefully.
5. Water and Moisture: This product should not be used near water, for example, near a bathtub, washbowl, kitchen sink, laundry tub, in a wet basement, near a swimming pool, swamp or salivating St. Bernard dog, etc.
6. Cleaning: Clean only with a dry cloth.
7. Ventilation: This product should be situated so that its location or position does not interfere with its proper ventilation. For example, the Component should not be placed on a bed, sofa, rug, or similar surface that may block any ventilation openings, or placed in a built-in installation such as a bookcase or cabinet that may impede the flow of air through ventilation openings.
8. Heat: This product should be stayed away from

heat sources such as radiators, or other devices producing heat.

9. Power Sources: This product should be connected to a power supply only of the type described in these operation instructions or as marked on this product.
10. Power Cord Protection: Power supply cords should be routed so that they are not likely to be walked upon or pinched by items placed upon or against them. Please pay particular attention to cords plugs, convenience receptacles, and the point where they exit this product.
11. Object and Liquid Entry: Care should be taken so that objects do not fall on, or liquids are not spilled into this product.
12. Damage Requiring Service: This product should be serviced only by qualified service personnel when:
 - A. The power-supply cord or the plug has been damaged; or
 - B. Objects have fallen, or liquid has spilled into this product; or
 - C. This product has been exposed to rain; or
 - D. This product does not appear to operate normally or exhibits a marked change in performance; or
 - E. This product has been dropped, or its chassis has been damaged.
13. Servicing: The user should not attempt to service this product beyond those means described in this operating manual. All other servicing should be referred to the Service Department.
14. To prevent electric shock, do not use this polarized plug with an extension cord, receptacle or other outlet unless the blades can be fully inserted to prevent blade exposure.
15. Grounding or Polarization: Precautions should be taken so that the grounding or polarization means of this product is not defeated.
16. Power Precaution: Unplug this product during lightning storms or when unused for long periods of time. Note that this product is not completely disconnected from the AC power source when the power switch is in the OFF position.

17. This machine does not exceed the Class A/Class B (whichever is applicable) limits for radio noise emissions from digital apparatus as set out in the radio interference regulations of the US Department of Communications.

AC-POWER SOURCES

This set should be operated only from the type of power source indicated on the marking label. If you are not sure of the type of electrical power supplied to your home, consult your dealer or local power company. For those sets designed to operate from battery power, or other sources, refer to the operating instructions.

This unit is designed for use with 120V/60Hz AC. If the area where you live have different power source, you may need to use a transformer to convert to 120 Volts AC.

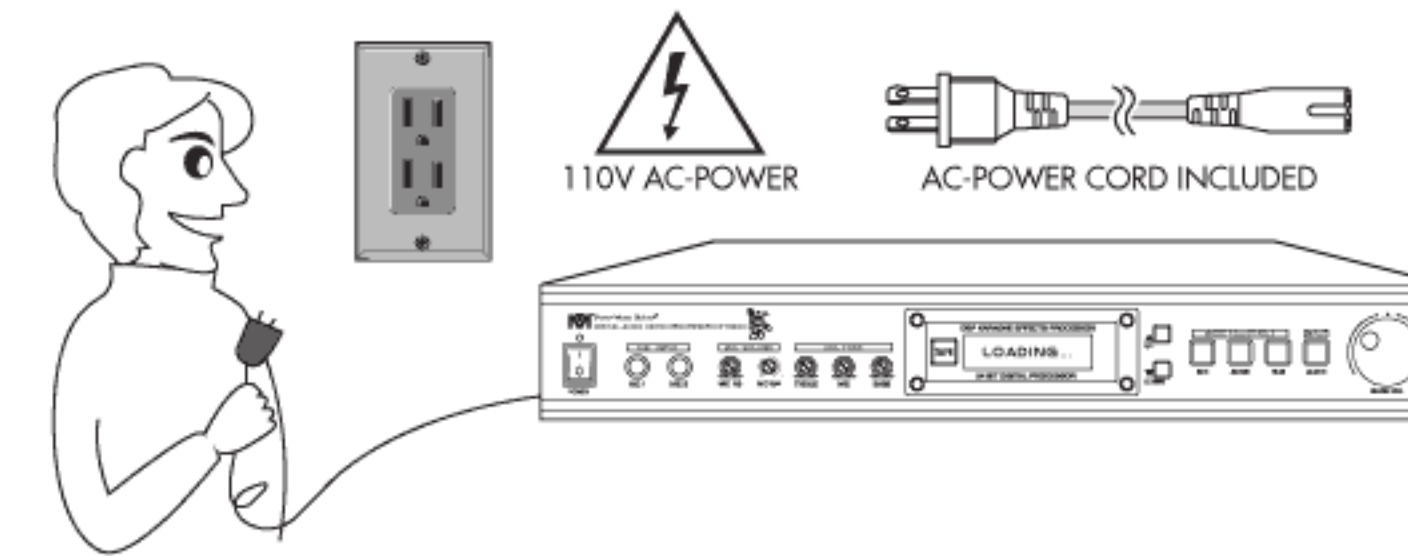

OVERLOADING

Do not overload wall outlets, extension cords or convenience receptacles beyond their capacity, since this can result in fire or electric shock.

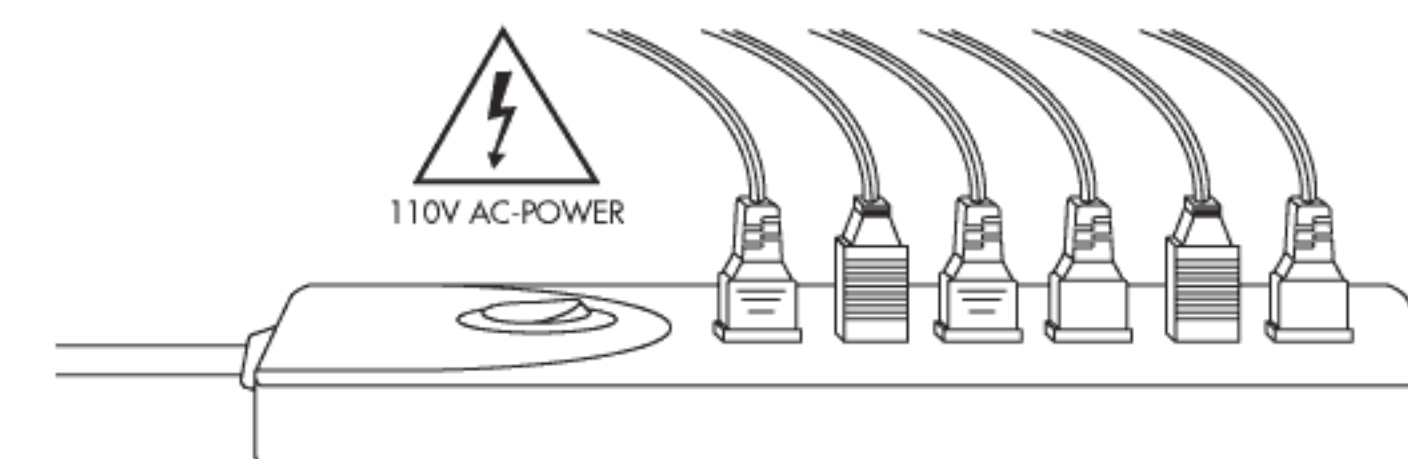

An appliance and cart combination should be moved with care. Quick stops, excessive force and uneven surfaces may cause the appliance and cart combination to overturn.

Do not place the electronic equipment onto the unstable table or stand. It is because it would fall easily from the unstable table or stand, so it may cause accident including personal injuries and damage the equipment. Please follow our instructions to install the equipment, or you may hire a professional technician to handle the installation for safety purpose.

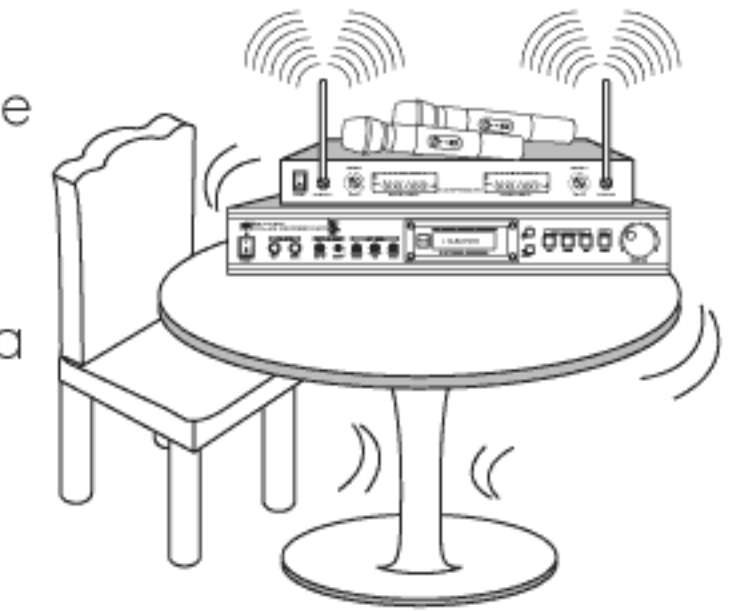

Do not place the set on an unstable cart, stand, tripod, bracket, or table. The set may fall, causing serious injury to a child or an adult, and serious damage to the set. Use only a cart stand tripod, bracket, or table recommended by the manufacturer.

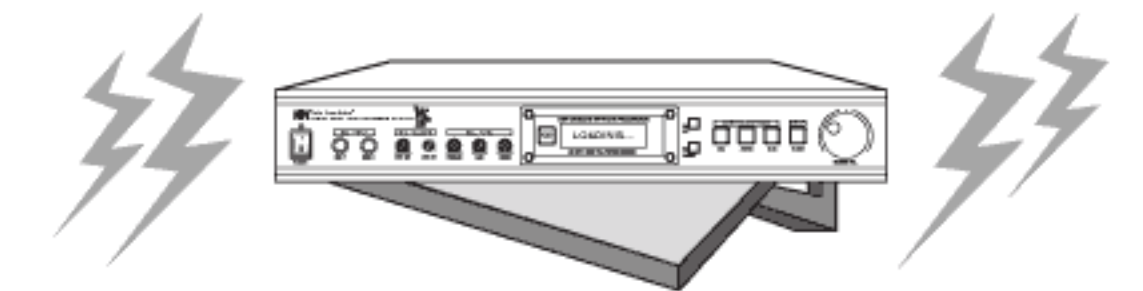

For the set with a three-wire grounding type ac plug: This plug will only fit into a grounding-type power outlet. This is a safety feature. If you are unable to insert the plug into the outlet, contact your electrician to have a suitable outlet installed. Do not defeat the safety purpose of the grounding plug.

Do not store the electronic equipment near water or area with moisture such as bathroom, kitchen sink, laundry area and swimming pool, etc.

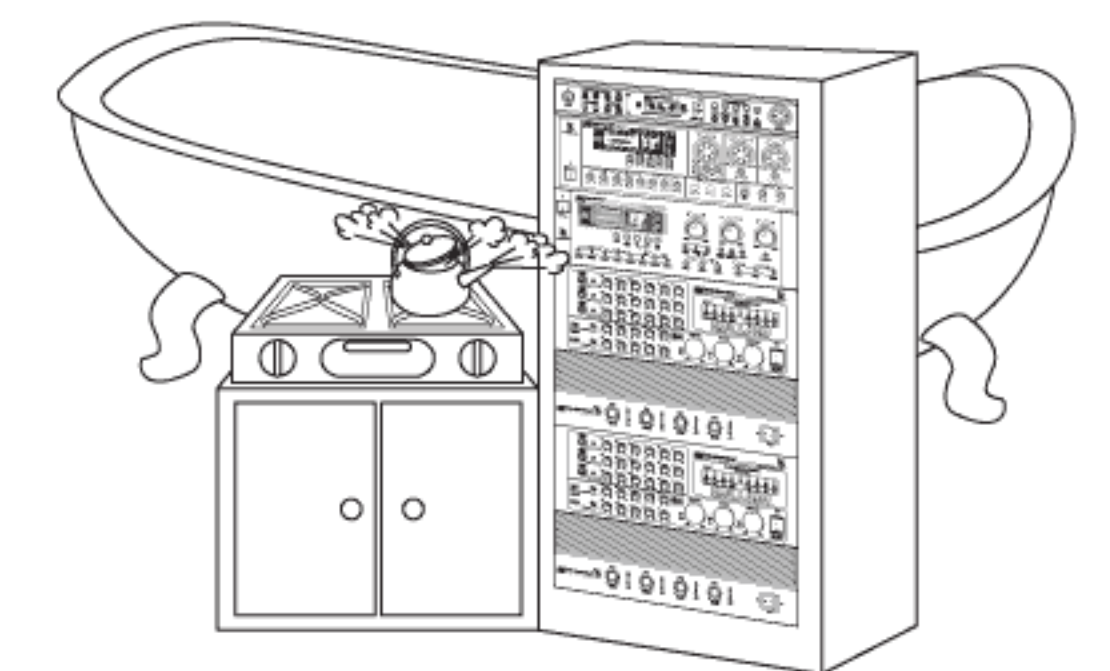

Do not transport the electronic equipment by yourself if its weight exceeds 70 pounds. It is recommended that two people work together to transport the equipment or by using hand truck and the like.

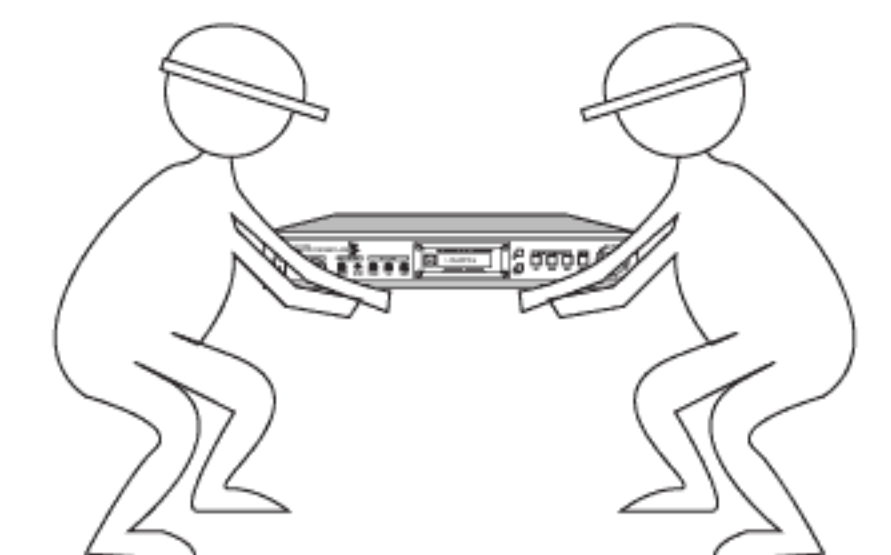

Do not place the electronic equipment directly under sunlight or close to the window. It may cause overheat on the electronic equipment by the sunlight.

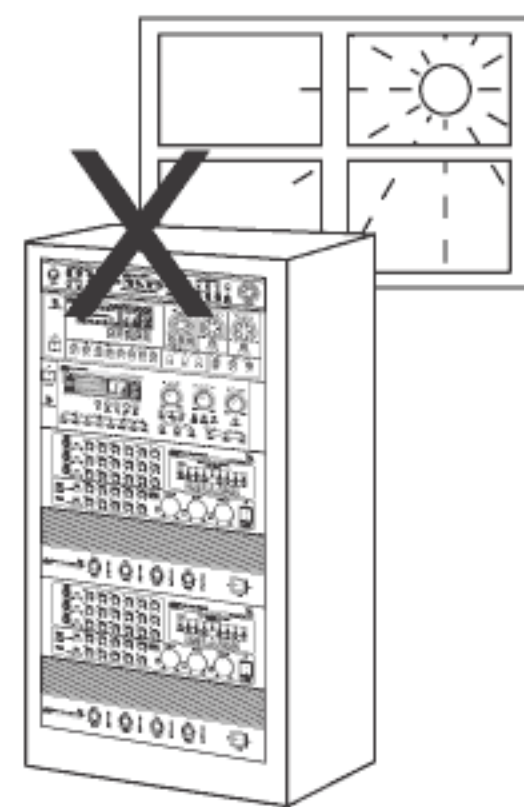

Do not block the openings and vents in the cabinet which is designed for the ventilation of the electronic equipment. The blocking may cause overheat in the electronic equipment because of insufficient circulation of air, so it would damage the electronic equipment.

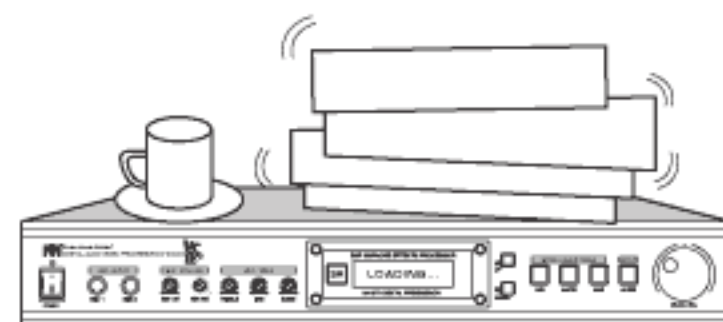

Do not place the electronic equipment near heat sources such as stoves, radiators and heaters, etc. Placing the electronic equipment too near to these heat sources would result in damaging the equipment and causing fire.

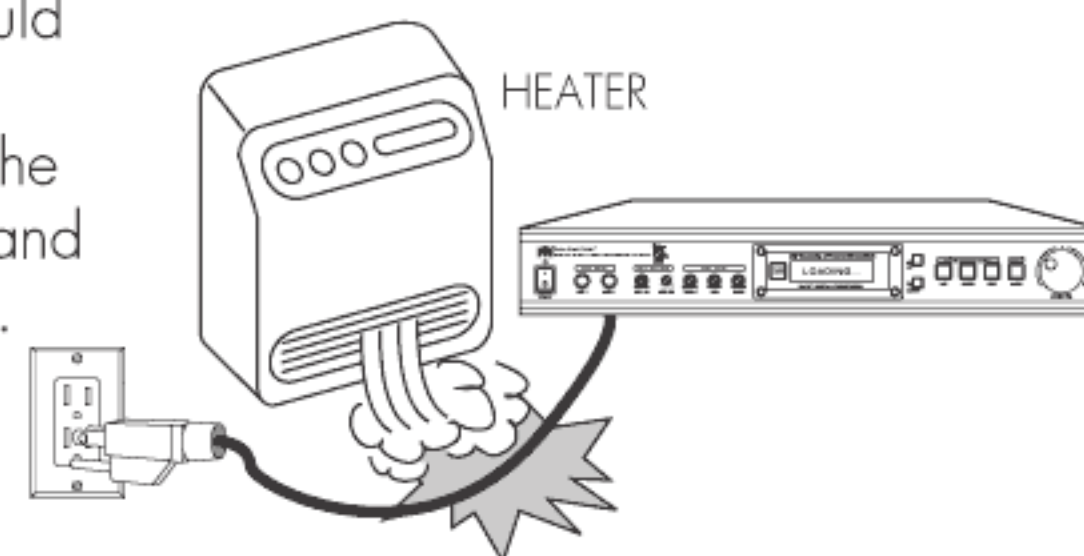

Using the Remote Control Unit

Use the remote control unit by pointing it towards the remote control sensor on the amplifier. Objects between the remote control unit and the remote control sensor may prevent proper operation.

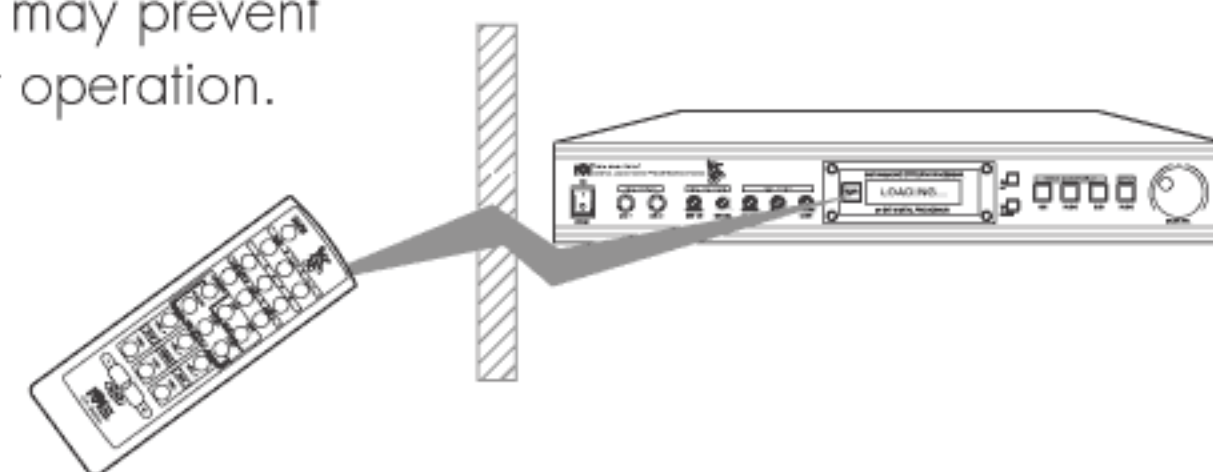

Cautions Regarding the Remote Control Unit

- Do not expose the remote control unit to shock. In addition, do not expose the remote control unit to liquids, and do not place in an area with high humidity.



- Do not install or place the remote control unit under direct sunlight. The heat may cause deformation of the remote control unit.
- The remote control unit may not work properly if the remote control sensor on the amplifier is under direct sunlight or strong lighting. In such cases, change the angle of the lighting or the amplifier, or operate the remote control unit closer to the remote control sensor.

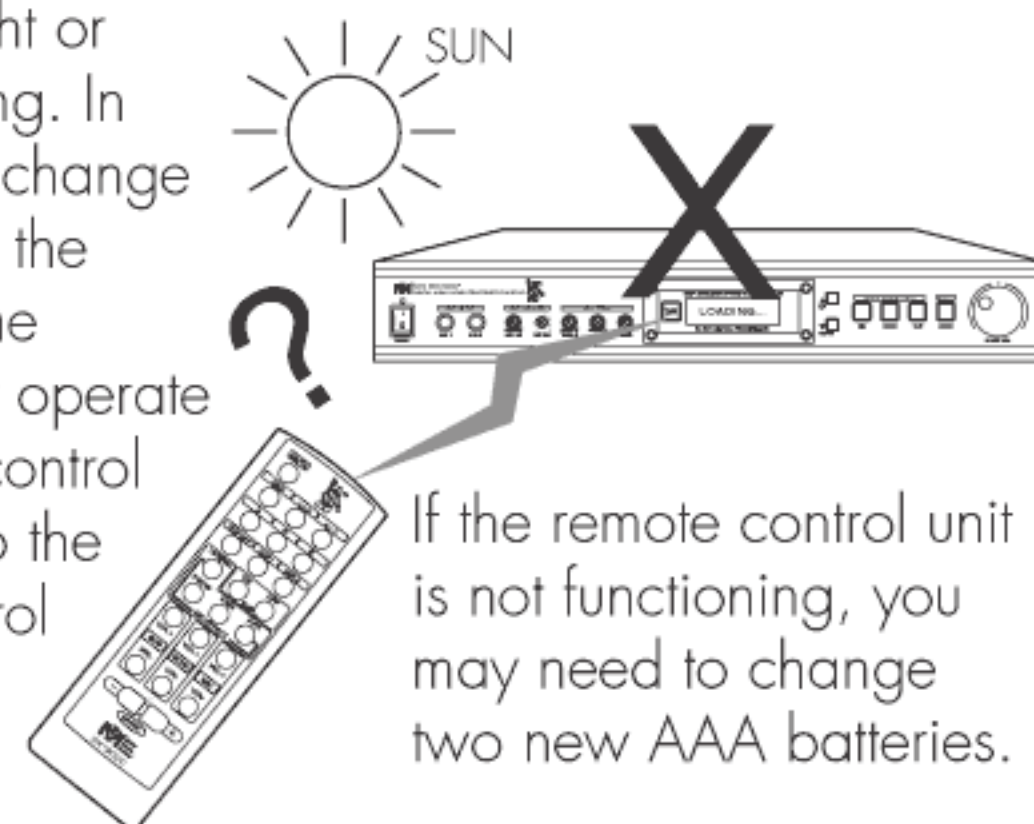

If the remote control unit is not functioning, you may need to change two new AAA batteries.

CONTENTS

Safety instructions.....	2~4
Introduction.....	5~6
Safety precautions.....	6
Specifications.....	6
Package accessories.....	7
Connector information.....	7
Name and functions of remote control buttons....	8~9
Features and functions of the mixer.....	10~11
Applications of a karaoke mixer.....	12~17
How to connect to home theater receiver.....	13~14
5-Channel connection diagram.....	18
5-Channel CPU processor.....	19
2-Channel stereo CPU processor connection.....	19
Portable.....	20
How to connect recorder & subwoofer.....	21
How to connect music A.V. source and V. monitor....	21
How to connect to an amplifier for 2-Channel.....	22
How to connect to an amplifier for 5-Channel.....	22
How to connect High Definition video.....	23
How to connect HDTV.....	24
How to connect microphone.....	25
Operating instructions.....	26~29
Troubleshooting.....	30
Physical.....	31
Optional for 19" rack mount kit.....	31
Final words to user.....	32
Maintenance.....	33~35

INTRODUCTION

The engineering team of Better Music Builder is a world's leader in designing audio and Karaoke equipment. Karaoke originated from Japan for entertainment. If you have been in the Karaoke nightclub (also called KTV) in Asia, you would be amazed by their advanced Karaoke technology and service. For example, the Karaoke nightclubs in Asia have lots of elegant VIP rooms for their customers. Each VIP room has a big plasma TV and a Karaoke machine with Video-On-Demand (VOD) feature which allows the customers to select songs, pay bills, place food & beverage orders and request room service.

Based on our observations and borrowing the proven design of Karaoke equipment in Asia, Better Music Builder has been constantly improving and developing state-of-the-art Karaoke technologies to satisfy the specific needs of the consumers in North America. Therefore, we have successfully designed both commercial and home entertainment Karaoke equipment for the North America consumers.

Thank you for choosing Better Music Builder DX-3000 Audio/Video Effect Processor. We appreciate your confidence in this innovative product. In fact, there are many different kinds of mixer in the market such as the DJ mixer and Karaoke mixer, etc. What are the differences? A DJ mixer has multiple music source input that can be mixed simultaneously. However, it is heavy, bulky and requires professional skill to control. In addition, it does not produce echo effects for Karaoke singing. On the other hand, a Karaoke mixer has built-in echo effect processor and key control. It is compact and easy to use. However, it has only one music input that can be selected at a time while a DJ mixer has multiple music input or selection. Depending on your needs, you may select either a DJ mixer or Karaoke mixer. You may also use both at the same time. However, you need professional skill and experience to operate both mixers at the same time.

DX-3000 is designed by our talented engineering team with many years of experience in audio equipment design. Our engineering team uses the state-of-the-art audio technology to design this product. DX-3000 is a

Central Processing Unit (CPU)-controlled machine with five channels to maximize the sound quality and effects.

DX-3000 is the second generation CPU audio/video processor with five-channel sound effects to produce the following special features. DX-3000 is suitable for PA use by church, school, company conference, café. It is excellent for Karaoke use and equipment rental.

Features

- Vocal only from the center speaker.
- Special microphone effect adjustments (i.e. Delay, Repeat and Echo) for both front and rear speakers. This would give you new audio experience.
- Built-In software programming to allow computer to operate easily.
- Three preset mic effects
- Four microphones input at the same time.
- Mic exciter with its own adjustments
- Both bypassing and non-bypassing XLR balanced paths for audio signals.
- DSP (Digital Signal Processing)
- 4 kinds of DSP Karaoke effects: Stereo effects, echo effects, two effects mixed with fixed echo return times (non-adjustable). Fixed effects setup by manufacturer. Parameters cannot be adjusted.
- High performance 24-bit multi-engine effect process
- Ultra-wide bandwidth from 2 Hz to 200 kHz for open sound
- Music tone with bass +/- 10dB and treble +/- 10dB
- High-performance 24-bit dual-engine Feedback Destroyer

- ❖ Two software engines allow independent or coupled functions on left and right channels on lines preamplifier
- ❖ Single-Shot mode automatically searches and attenuates feedback frequencies and locks the filter until manually reset
- ❖ Music modulation with 9-step key control and two built-in effects for selecting
- ❖ Music volume lock for locking up your favorite audio settings.
- ❖ 2-Way stereo crossover
- ❖ 24 dB/octave, state-variable Linkwitz-Riley filters for precise frequency separation
- ❖ Absolutely flat summed amplitude response, zero phase difference
- ❖ Subwoofer output with independent frequency control
- ❖ On/Off setting for subwoofer
- ❖ Subwoofer auto cut
- ❖ Microphone reverb (echo) time delay adjustable from 40 mS to 230 mS (130 default) and REPEAT adjustable from 0 to 16.

SAFETY PRECAUTIONS

Selecting fine audio equipment such as the unit you've just purchased is only the first step to your musical enjoyment. Now it's time to consider how you can maximize the fun and the safety of your new equipment. We want you to get the most out of your equipment by playing it at a safe level without affecting your hearing. Sound can be very harmful. Over time your hearing "comfort level" adapts to higher volume of sound. What sounds "normal" can actually be loud and harmful to your hearing. Therefore, please guard against this by setting your equipment at a safe level before your hearing adapts. To establish a safe level, you can start your volume control at a low

setting, then slowly increase the sound until you can hear it comfortably and clearly. If used wisely, your new sound equipment will provide you a pleasant experience in music. Since hearing damage from loud noise is often undetectable until it is too late, we recommend you avoid prolonged exposure to excessive noise. The following noises can be dangerous under constant exposure. Therefore, please be cautious with the dB level when playing your new equipment.

Decibel Level	Example
120 dB	Rock band concert in front of speakers, thunderclap
140 dB	Gunshot blast, jet plane
180 dB	Rocket launching pad

SPECIFICATIONS

Music Input Section	
S/N Ratio.....	>90dB
THD.....	0.01%
Input Sensitivity/Impedance..	0.707v/47k. ohm
Frequency Response.....	20Hz~20kHz ±2dB
Max. Output.....	4Vpp/60W
HF (increase/attenuate).....	±10dB
LF (increase/attenuate).....	±10dB
Key Control.....	9 Steps
Super Bass (SUB)	
THD.....	0.07% 20Hz~15kHz
Mic. Input Section	
S/N Ratio.....	>80dB (effect on)
THD (effect off).....	0.04% 50Hz~16kHz
Frequency Response.....	50Hz~20kHz ±3dB
Input Sensitivity/Impedance...	100mv~500mv/4.7KW
Equalize	
Low.....	100Hz±5dB
Middle.....	1kHz±5dB
High.....	10kHz±5dB
Standard Power.....	AC 120V/60Hz
Power Consume.....	35 W
Dimensions (WxHxD).....	17x3x13 (inches)
Weight.....	11 lbs/5 Kg
Shipping Weight.....	14 lbs/6.35 Kg

PACKAGE ACCESSORIES

The Package accessories include a remote control and one AC power cord. All other accessories mentioned in the manual for installation purpose are not included. They are sold separately.

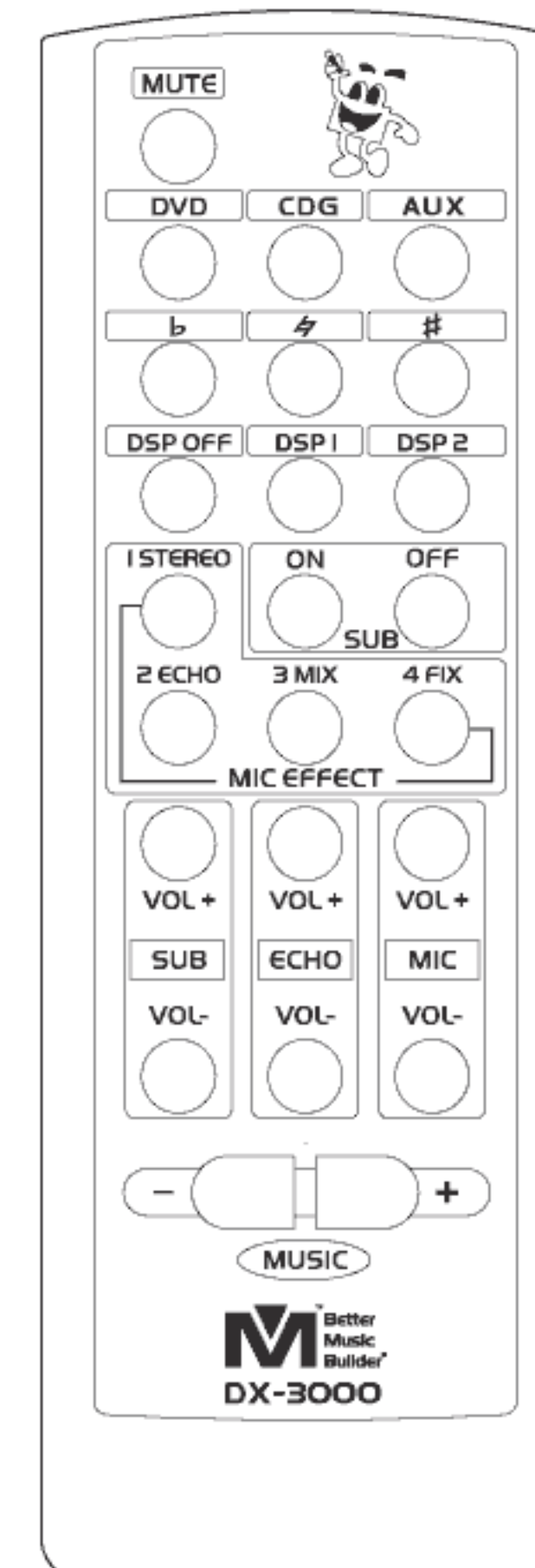

Remote control one unit



Consumer warranty and registration card
 <Mail in U.S.A. only>
 Consumers from Canada can get the warranty card by downloading it from our website www.BetterMusicBuilder.com.

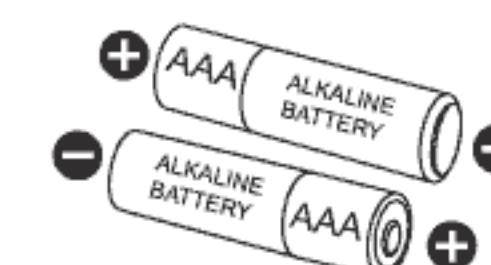

Battery size: AAA (R6 1.5 V)



Plastic Screw Driver
 Please use this plastic screw driver

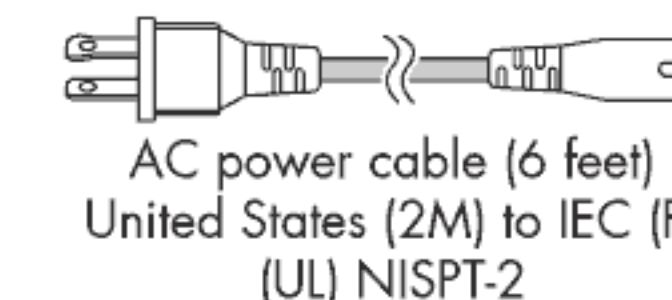

AC power cable (6 feet)
 United States (2M) to IEC (F)
 (UL) NISPT-2

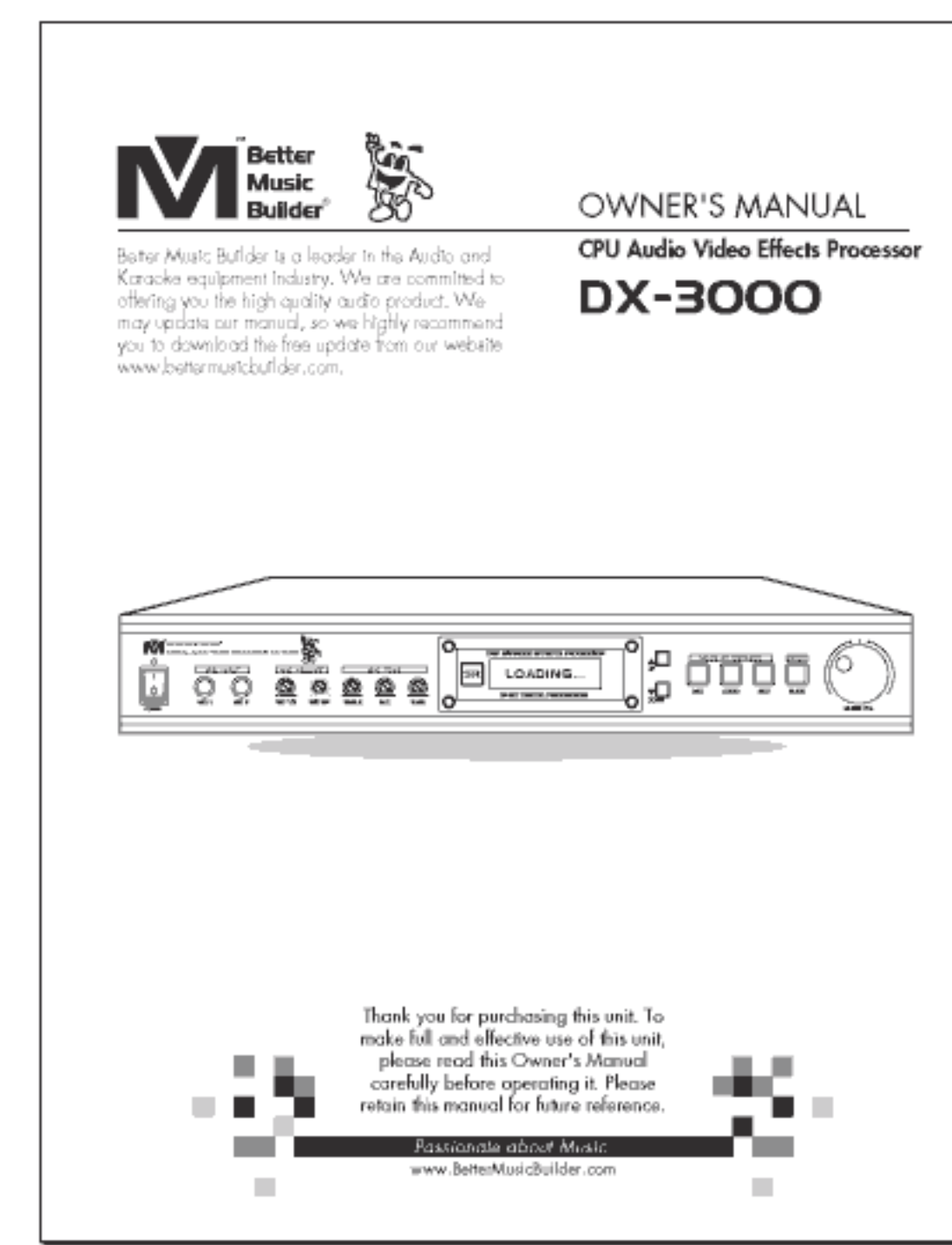

Owner's manual

CONNECTOR INFORMATION

BALANCED XLR CONNECTORS

	XLR	TRS
Hot (+)	Pin 2	Tip
Cold (-)	Pin 3	Ring
Shield (Ground)	Pin 1	Shield

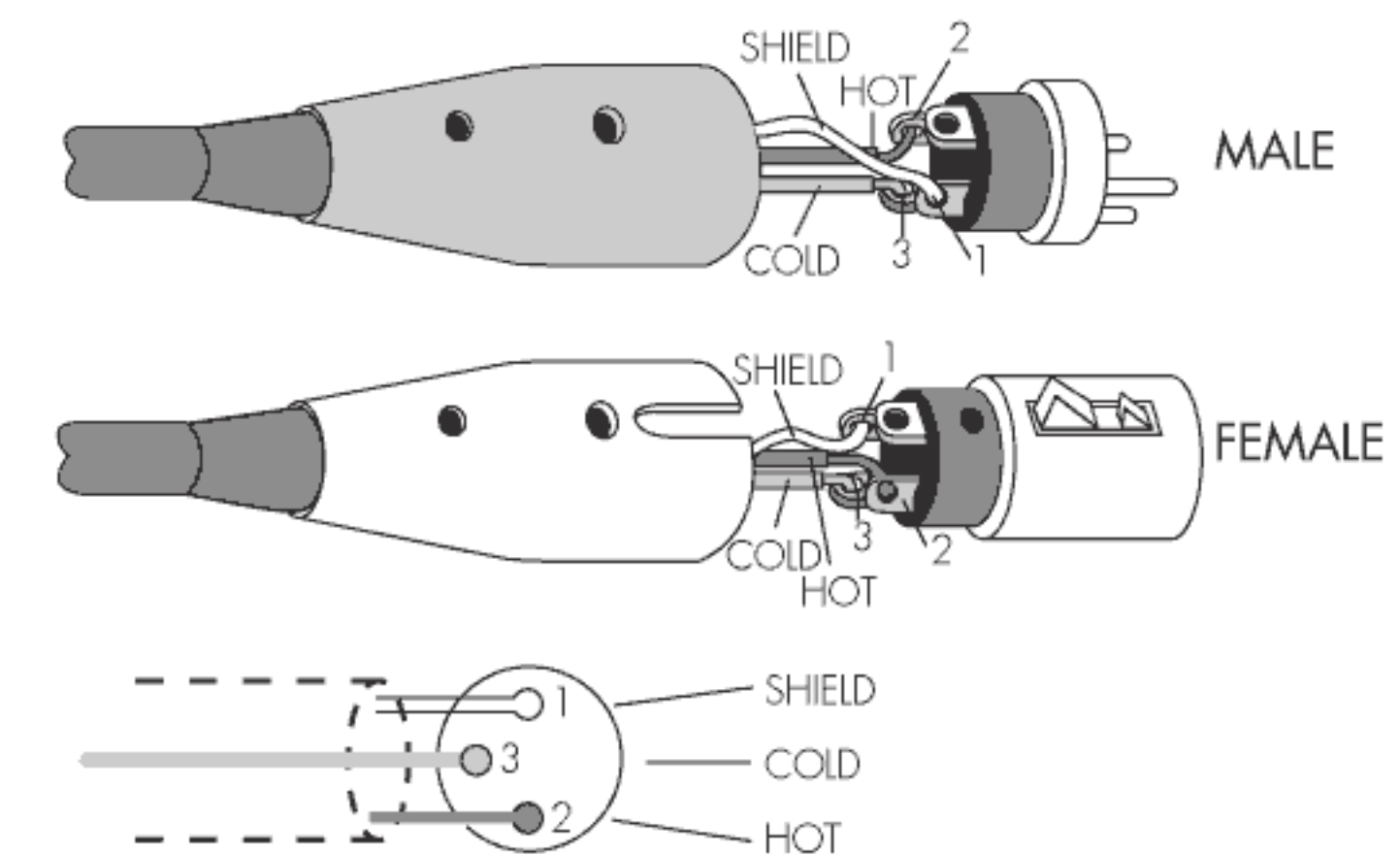

BALANCED 1/4" TRS PLUG

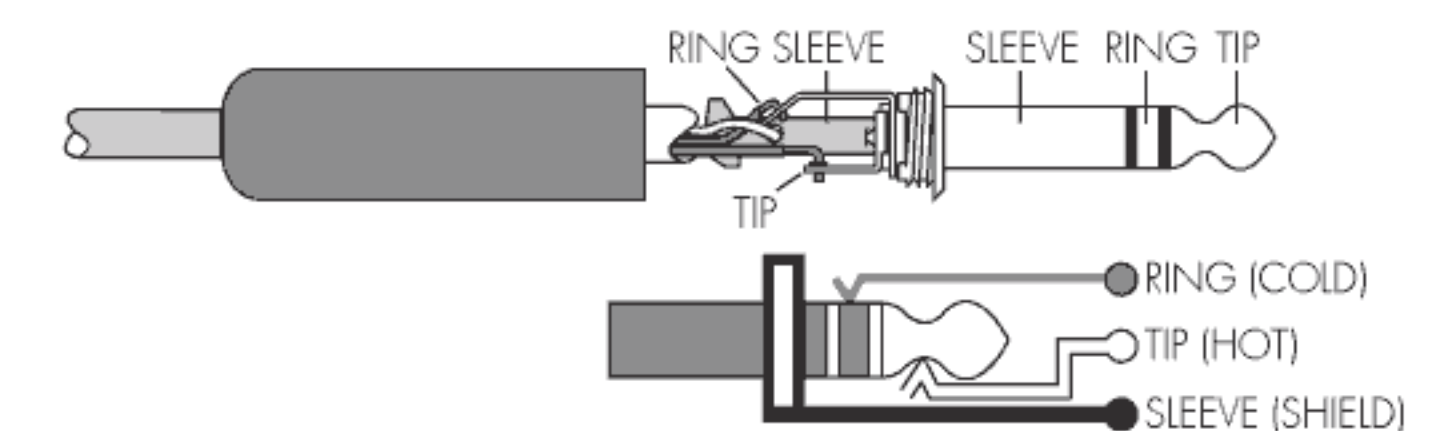

UNBALANCED 1/4" TRS PLUG

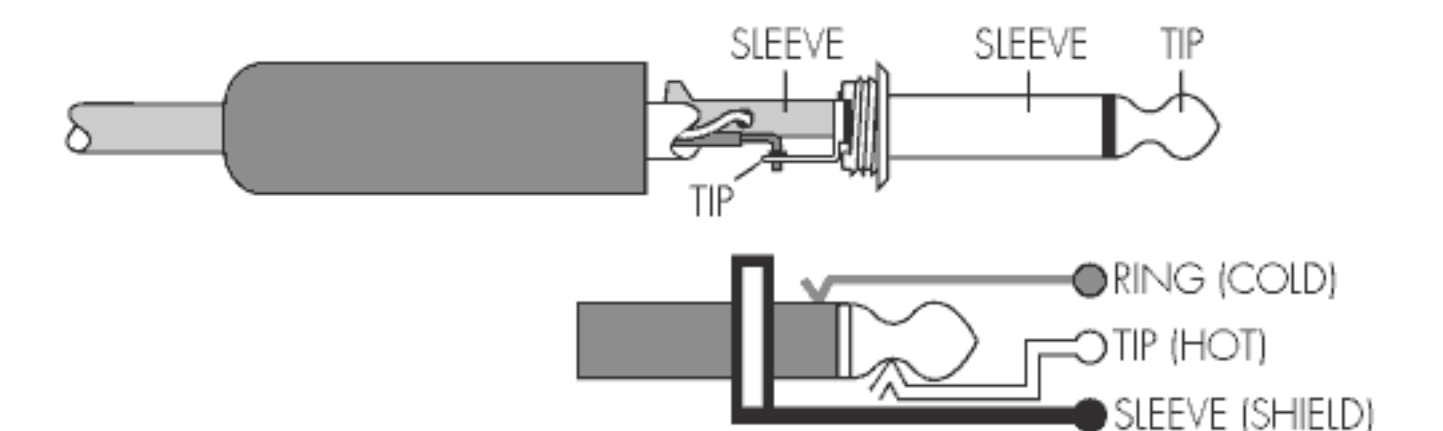

RCA UNBALANCED JACK

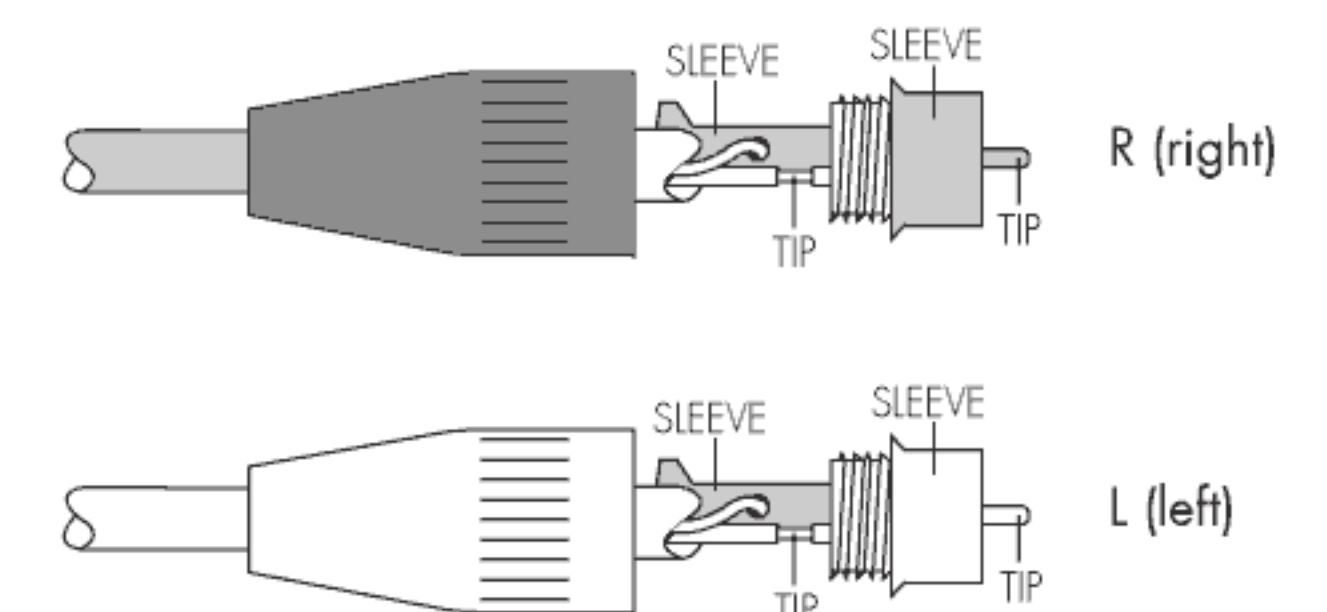

NAMES AND FUNCTIONS OF REMOTE CONTROL BUTTONS

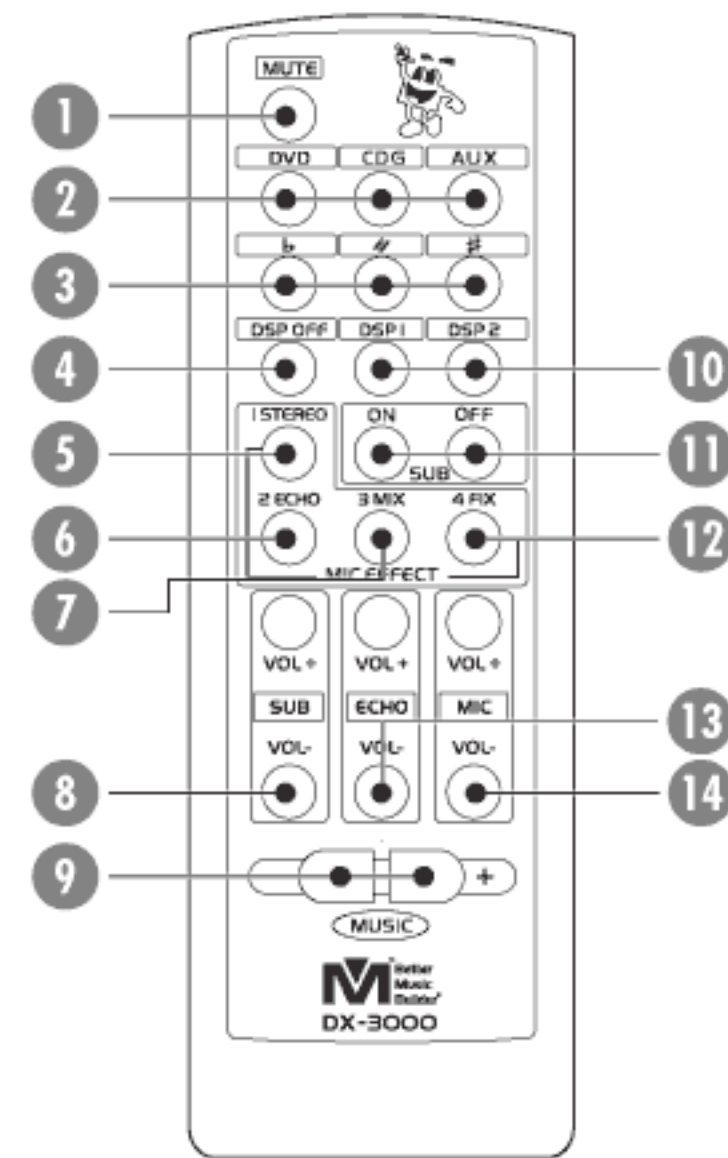

- 1 **MUSIC MUTE BUTTON**
- 2 **INPUT SELECT BUTTON: DVD, CDG, AUX**
- 3 **KEY CONTROL: ♭ LOW, ⚡ NATURAL, # HIGH**
- 4 **MUSIC MODULATOR CONTROL BUTTON DSP OFF**
- 5 **1. STEREO KARAOKE EFFECT SELECT**
- 6 **2. ECHO KARAOKE EFFECT SELECT**
- 7 **3. MIXED KARAOKE EFFECT SELECT**
- 8 **SUPER BASS VOLUME UP & DOWN BUTTON**
- 9 **MUSIC MASTER VOLUME CONTROL UP & DOWN BUTTON**
- 10 **DSP EFFECT 1 & 2**
- 11 **SUPER BASS ON/OFF BUTTON**
- 12 **4. FIXED KARAOKE EFFECT SELECT**
- 13 **ECHO VOLUME UP & DOWN BUTTON**
- 14 **MICROPHONE VOLUME UP & DOWN BUTTON**
- 15 **OPEN BATTERY COVER**

Open the battery compartment cover on the back of the remote control unit. The cover should open easily if you press on in with your thumb while sliding it in the direction of the arrow.

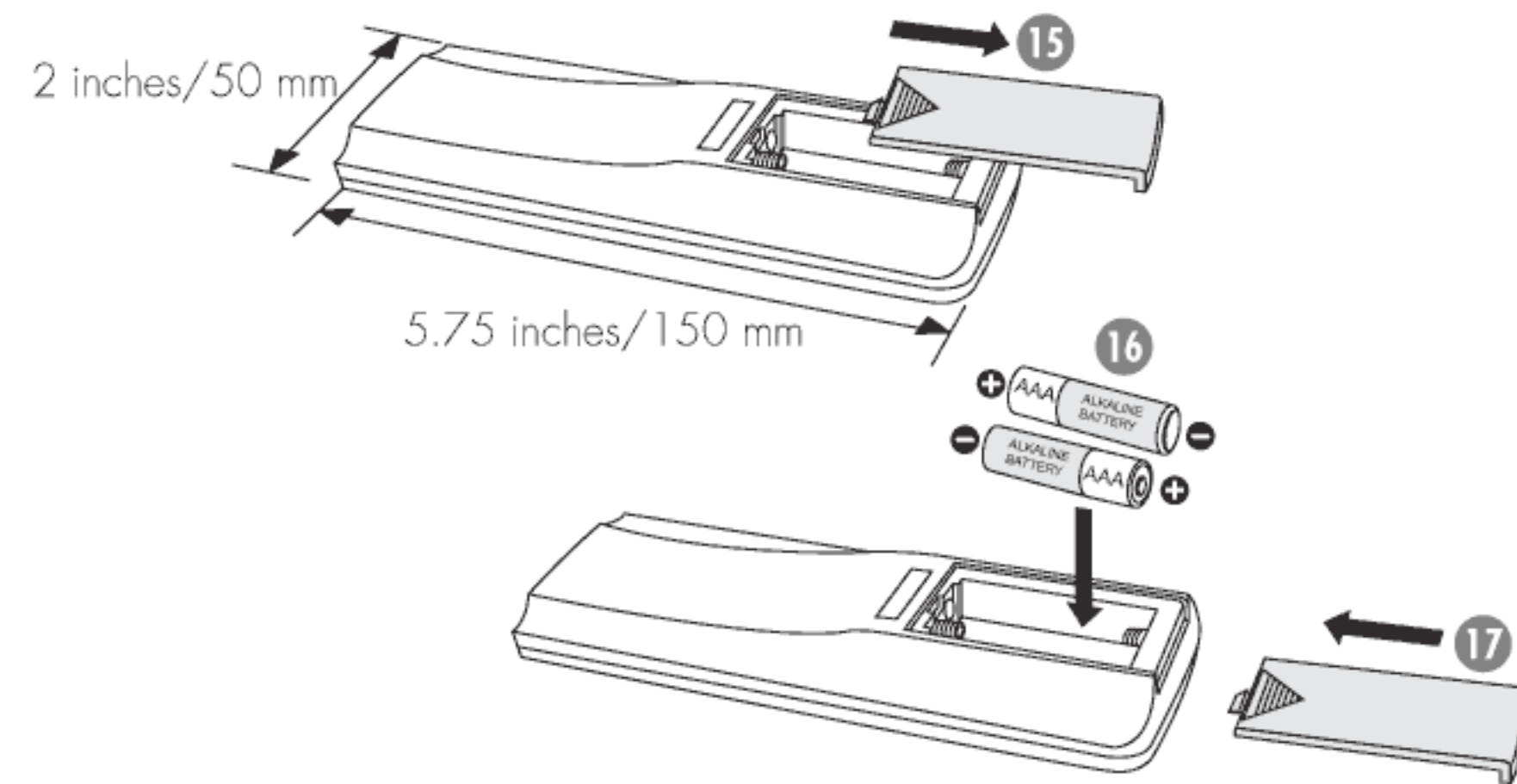

- 16 **INSERTING BATTERIES**
Insert two size AAA 1.5V (R6) alkaline batteries as shown.

- 17 **CLOSE BATTERY COVER**
Close the cover of the battery case.

NOTE

Remove the batteries to avoid damage from possible battery leakage whenever you anticipate that the remote control will not be used for an extended period.

Handle the remote control with care. Avoid dropping it, getting it wet, or placing it in direct sunlight, near a heater, or where the humidity is high.

- 18 **USING THE REMOTE CONTROL UNIT**
When operating the remote control unit, point the unit's infrared signal transmitter at the remote control remote sensor "SR" on the front panel of the AV processor. The remote control unit can be used within a range of about 18 feet (6m) from the remote sensor, and within angles of up to about 30 degrees.

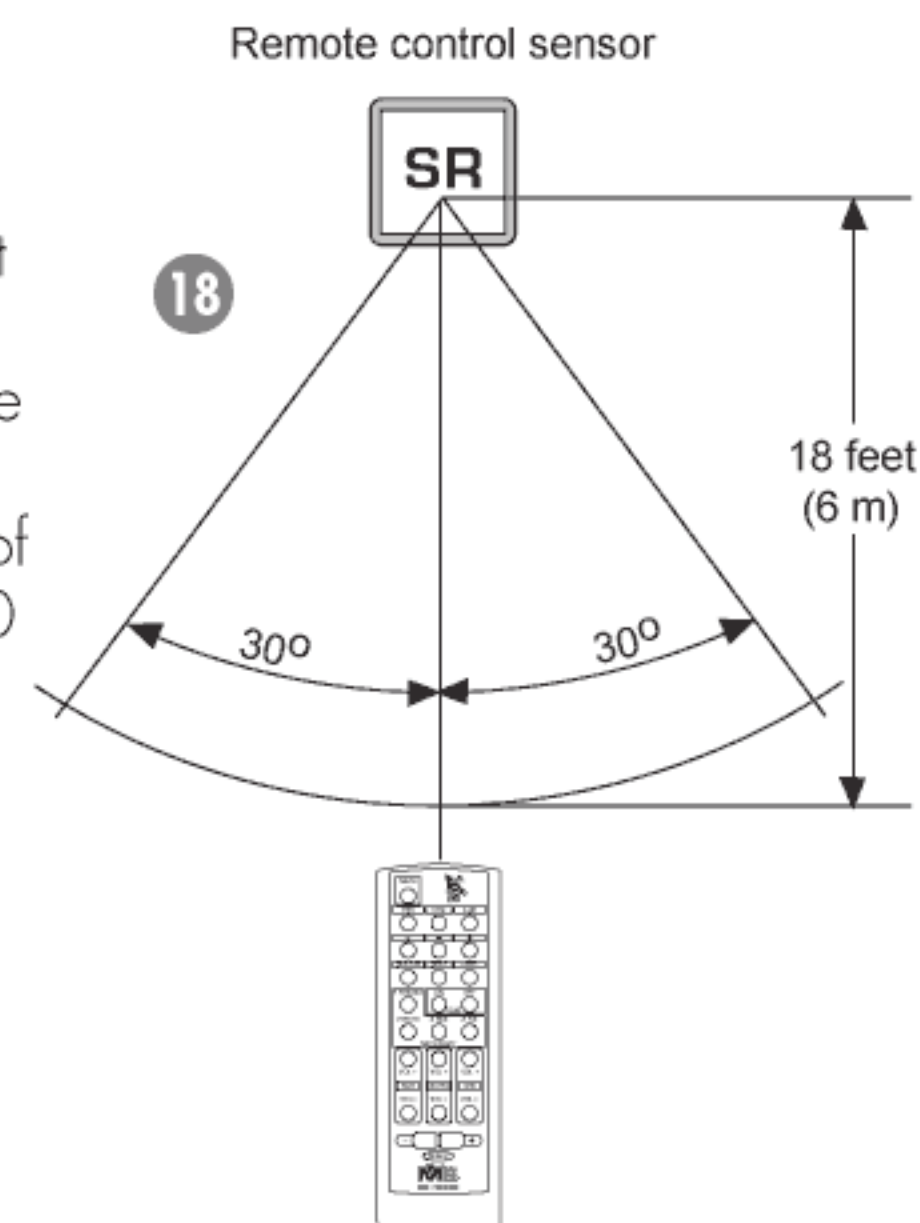

NAMES AND FUNCTIONS OF REMOTE CONTROL BUTTONS

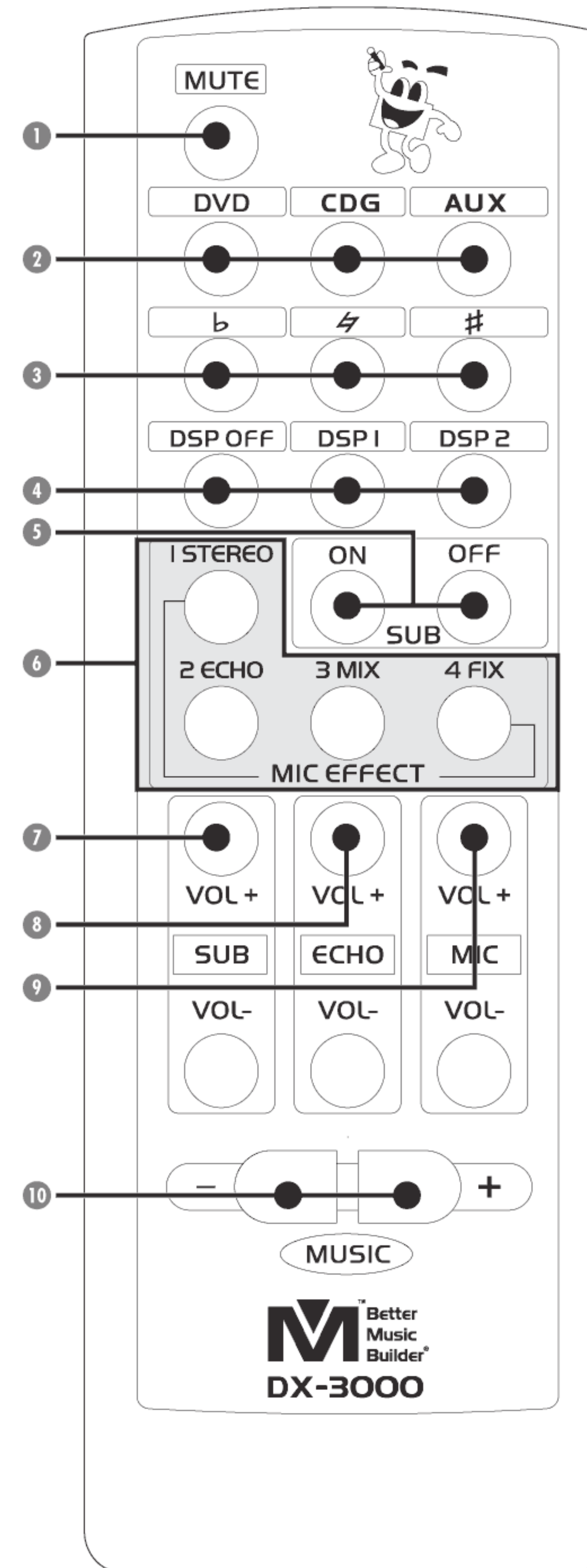

BASIC ADJUSTMENT SETTINGS

- 1 **MUSIC MUTE BUTTON**
Music Mute Button is for music only. The microphones are still active.
- 2 **INPUT SELECT BUTTON: DVD, CDG, AUX**
When you press this button to select the CDG input, it would not work if DVD is in use. The reason is that this unit is designed with DVD as the first priority input. It is designed for commercial karaoke use. In the KTV karaoke room the select songs must go to the DVD input. If no one selects a song, the DJ control center may switch the line input to play background music (BGM) or to advertise. When someone selects a song, it will automatically switch back to the DVD input.

If you want to use the CDG input, you must turn off the signal connected to the DVD input. If you don't have any equipment connected to the DVD input you can connect the CDG player directly to the DVD input.

- 3 **KEY CONTROL: ♭ LOW, ⚡ NATURAL, # HIGH**
Key control button controls the music speed.
- 4 **MUSIC MODULATOR CONTROL BUTTON, DSP EFFECT 1 and DSP EFFECT 2**
DSP stands for Digital Signal Processing. Here "1" effect is to simulate DISCO. DSP "2" effect is to simulate HALL.
- 5 **SUPER BASS ON/OFF BUTTON**
- 6 **MIC EFFECT SELECT**
Mic effect 1, 2, and 3 have different vocal effects pre-set by the manufacturer. You have to listen carefully to notice the difference. The "FIX" is to lock up the user's favorite vocal effect settings.

NOTE

When "FIX" is selected, "ECHO VOLUME," "DELAY," and "REPEAT" are not adjustable.

- 7 **SUB MASTER VOLUME CONTROL UP & DOWN BUTTON**
Music Master Volume control from 00dB to 80dB. You can select up and down.
- 8 **ECHO VOLUME UP & DOWN BUTTON**
Microphone Echo Volume control from 00dB to 50dB. You can select up and down.
- 9 **MICROPHONE VOLUME UP & DOWN BUTTON**
Microphone Master Volume control from 00dB to 50dB. You can select up and down.
- 10 **MUSIC MASTER VOLUME CONTROL UP & DOWN BUTTON**

NAMES AND FUNCTIONS OF FRONT PANEL COMPONENTS

- 1 POWER SWITCH**
Press this switch button UP to turn the power ON. Press the switch button DOWN to turn the power OFF (I=ON, O=OFF). Light blue LED is ON when unit is powered.
- 2 MIC. 1 INPUT 1/4 INCH JACK**
- 3 MIC. 2 INPUT 1/4 INCH JACK**
- 4 MIC. (MICROPHONE) 1/3 VOLUME CONTROL**
This controls microphone 1 and microphone 3 volume level.
- 5 MIC. (MICROPHONE) 2/4 VOLUME CONTROL**
This controls microphone 2 and microphone 4 volume level.
- 6 MIC. TREBLE CONTROL**
Adjusts the microphone 1 and microphone 2 high frequency response.
- 7 MIC. (MID) MIDDLE CONTROL**
Adjusts the microphone 1 and microphone 2 middle frequency response.
- 8 MIC. BASS CONTROL**
Adjusts the microphone 1 and microphone 2 low frequency response.
- 9 THE DISPLAY WINDOW FOR RECEIVING SIGNAL OF REMOTE CONTROL**
- 10 LCD System status display**
- 11 UP CONTROL BUTTON**
Should use it to change the parameters of MODE ADJUSTABLE items.
- 12 DOWN CONTROL BUTTON**
Should use it to change the parameters of MODE ADJUSTABLE items.
- 13 MIC. MODE**
Mic mode program button.
- 14 AUDIO MODE**
Music mode program button
- 15 SUB MODE**
Super bass mode program button
- 16 AUDIO INPUT**
Music input select button
- 17 MUSIC VOLUME CONTROL**
This control allows you to adjust the volume of the musical source.

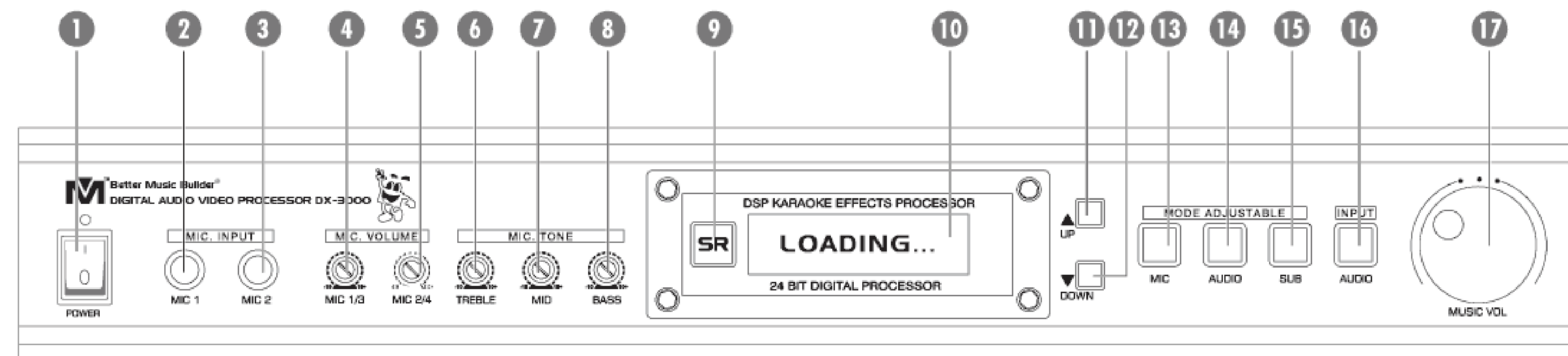

NAMES AND FUNCTIONS OF REAR PANEL COMPONENTS

- 18 AUX ADJUST SENSOR VOLUME**
- 19 AUX AUDIO INPUT TERMINAL**
- 20 CDG AUDIO INPUT TERMINAL**
- 21 DVD AUDIO INPUT TERMINAL**
- 22 AUX VIDEO INPUT TERMINAL**
- 23 CDG VIDEO INPUT TERMINAL**
- 24 DVD VIDEO INPUT TERMINAL**
- 25 SUB WOOFER OUTPUT TERMINAL**
- 26 REC AUDIO OUTPUT TERMINAL**
Audio output for recording
- 27 MAIN 1 AUDIO OUTPUT TERMINAL**
This 1/4" Audio-Out connects to an amplifier. If there is any humming sound, we recommend you to connect to the MAIN 2, which is a XLR balanced Audio-Out, to reduce the humming sound.
- 28 MAIN 2 AUDIO OUTPUT TERMINAL**
XLR Pre-out to amplifier
- 29 REAR MICROPHONE 1/4" INPUT TERMINALS**
- 30 WIRED REMOTE CONTROL CONNECTOR**
- 31 120V 60Hz 35W AC-POWER INPUT JACK**
- VIDEO MONITOR OUTPUT TERMINAL**

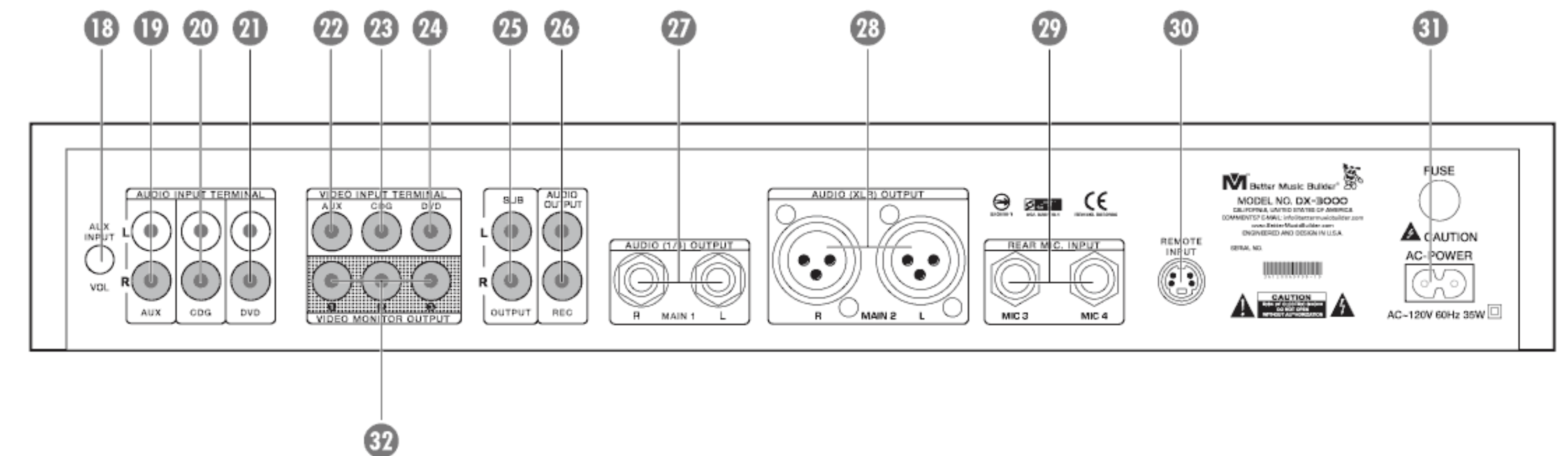

APPLICATIONS OF A KARAOKE MIXER

INTRODUCTION

Nowadays, many families have home theater systems. In general, the output of home theater receiver ranges from 30 to 130 watts. Home theater provides music tune only, so an output of 130 watts from the speakers is good enough for home theater. If you want to sing Karaoke, you need a mixer. The basic things you need for Karaoke singing are summarized as follows:

1. Microphone(s)
2. Microphone effect adjustment
3. Music key control
4. Mixed effects for music and vocal

Some people may use magic microphone for Karaoke singing. Using magic microphone has pros and cons. In general, a magic microphone has 20,000 built-in songs, so it is very convenient and economical. However, if you just connect the magic microphone directly to the television, you are running the risk of blowing out the TV speakers because speaker output of television is too low and it normally has only 30 watts. Therefore, the quality of the sound output is very poor. It can only be used in a small room for less than 100 square feet. Please refer to page 13.

DIFFERENT SETUPS

The engineering team of Better Music Builder has spent many years of research efforts in figuring out the different setups for mixer to Karaoke systems to achieve the greatest results for performance. Based on our research and experience, depending on the room size, there are five different setups of mixer to Karaoke system.

1. ROOM SIZE FOR LESS THAN 300 SQUARE FEET USING 5.1 HOME THEATER SYSTEM

A Karaoke mixer is connected to the 5.1 home theater receiver (rated 75 to 130 watts) directly.

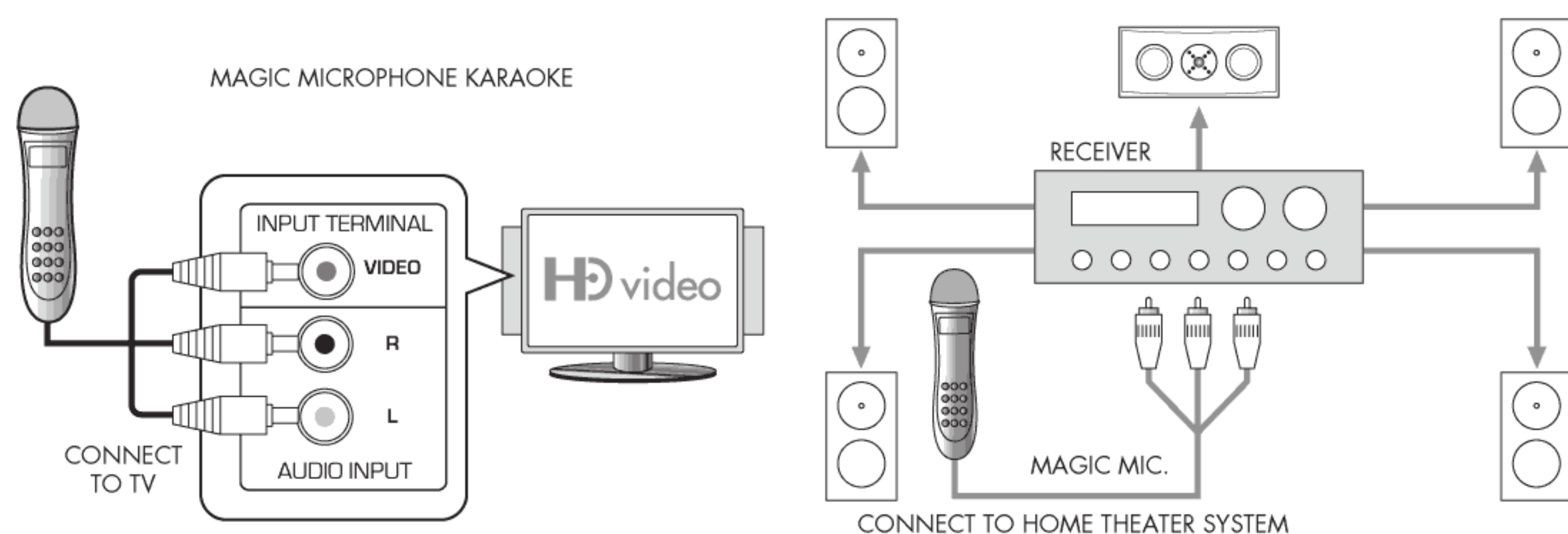

HOW TO CONNECT TO HOME THEATER RECEIVER

2. ROOM SIZE FROM 600 TO 1,000 SQUARE FEET

A Karaoke mixing amplifier is required to be connected to a pair of Karaoke speakers.

When you connect mixer to Home theater receiver, you must connect Main 1 or Main 2 out to the receiver input. You must ensure that when you select the audio/video source (DVD, CDG and AUX, etc.) at the Karaoke mixer input, and the output of Karaoke mixer is then connected to the 5.1 home theater receiver at the one of the terminal inputs (such as DVD,DTV, VCR, DVR and SAT, etc.). For example, if you select DVD at the audio/video source of Karaoke mixer, then you may select one of the terminal inputs at the home theater receiver depending on to which corresponding input terminal you connect with the output of the Karaoke mixer.

Audio/Video separate input: If you want a High-Definition (HD) video HDTV display, you need to connect the "Video Output" (Component) of DVD player to the "Input" of HDTV. Therefore, you must select the "Video Input" at the HDTV correctly; otherwise, there is no image on the TV.

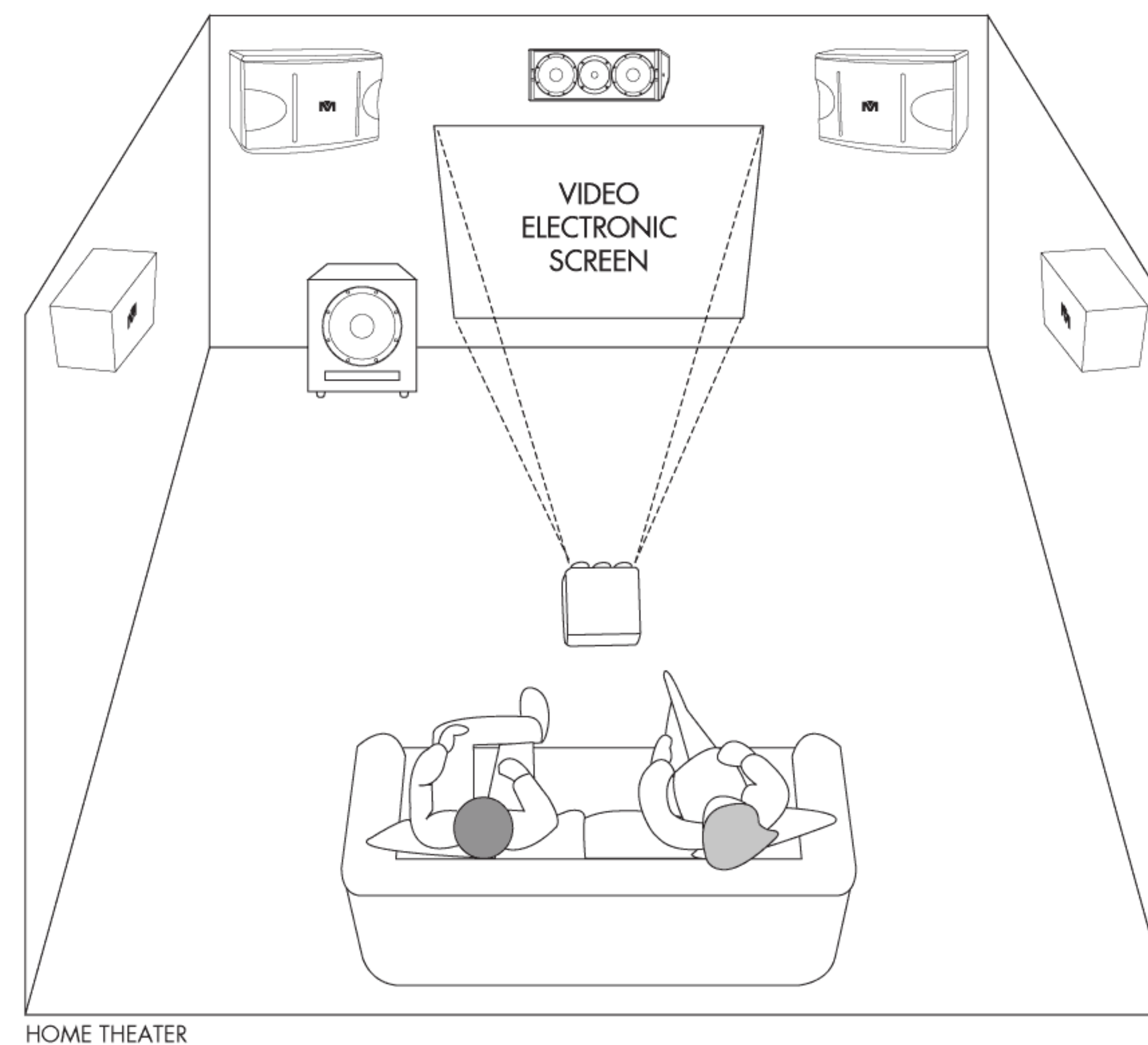

HOW TO CONNECT TO HOME THEATER RECEIVER

DX-3000 REAR VIEW

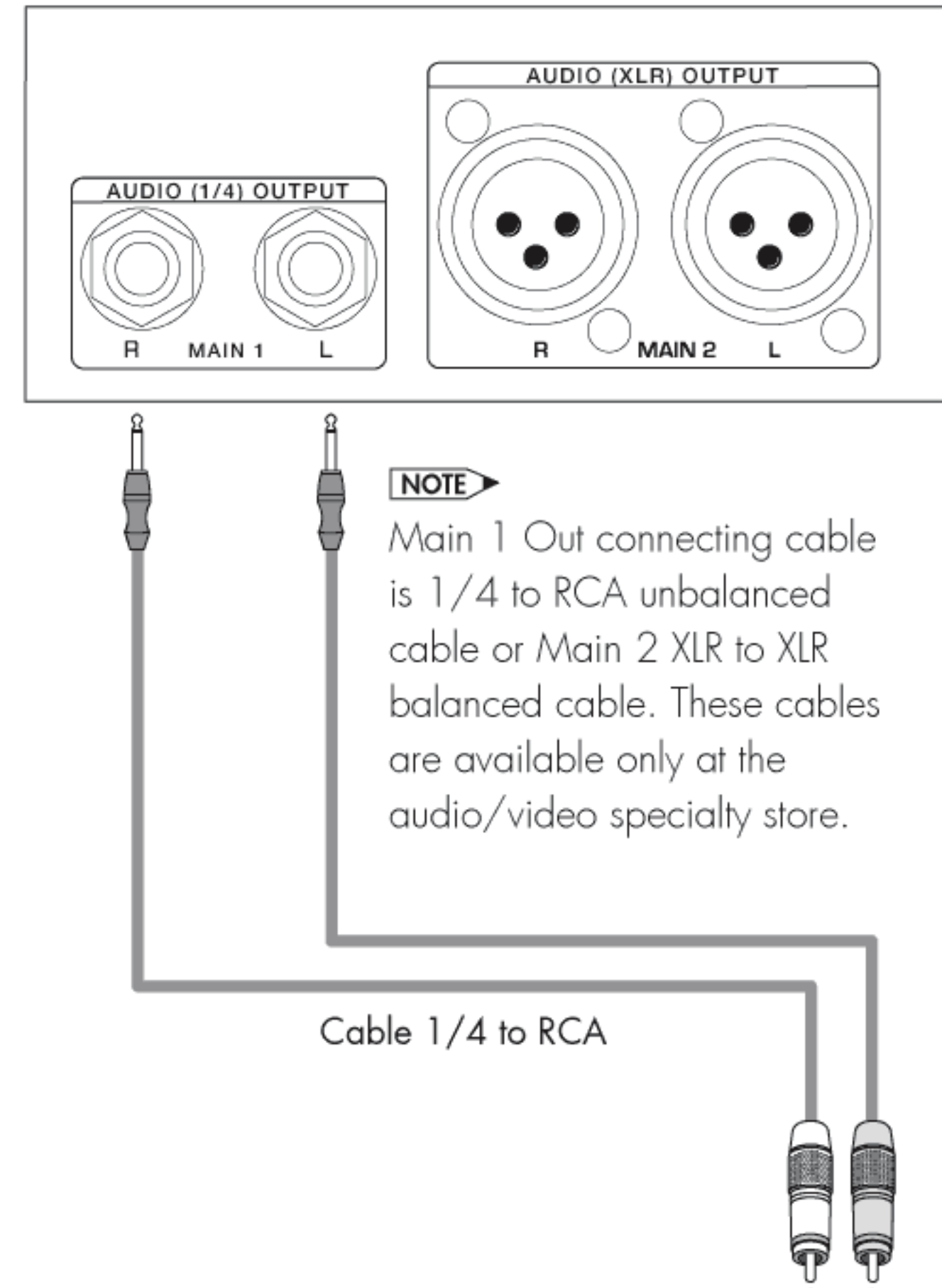

NOTE
Main 1 Out connecting cable is 1/4 to RCA unbalanced cable or Main 2 XLR to XLR balanced cable. These cables are available only at the audio/video specialty store.

When you connect the Karaoke mixer to the home theater receiver, you must connect it to MAIN 1 (1/4 Out) and MAIN 2 (XLR Balanced). To connect the home theater receiver to any terminal, you may use a special cable for connection. Please refer to the following diagrams.

When you connect the mixer (from MAIN 1) out to any of the input terminals in the home theater receiver, you must make sure that you also select the right input source (such as DVD, AUX, and CDG, etc.) at the front panel. For example, when you connect the MAIN 1 from the mixer to the "DVD" (terminal input on the back) of the home theater receiver, you must also select the "DVD" at the front panel of home theater receiver.

When you connect the power subwoofer to the home theater receiver, you must first turn off all sound effect selections (such as DTS, THX and AC-3, etc.) from the home theater receiver. Those sound effects are intended for movie playing, but not for music and Karaoke singing because Karaoke singing requires a normal signal. Any singing effects must be produced from the Karaoke mixer.

HOME THEATER RECEIVER REAR VIEW

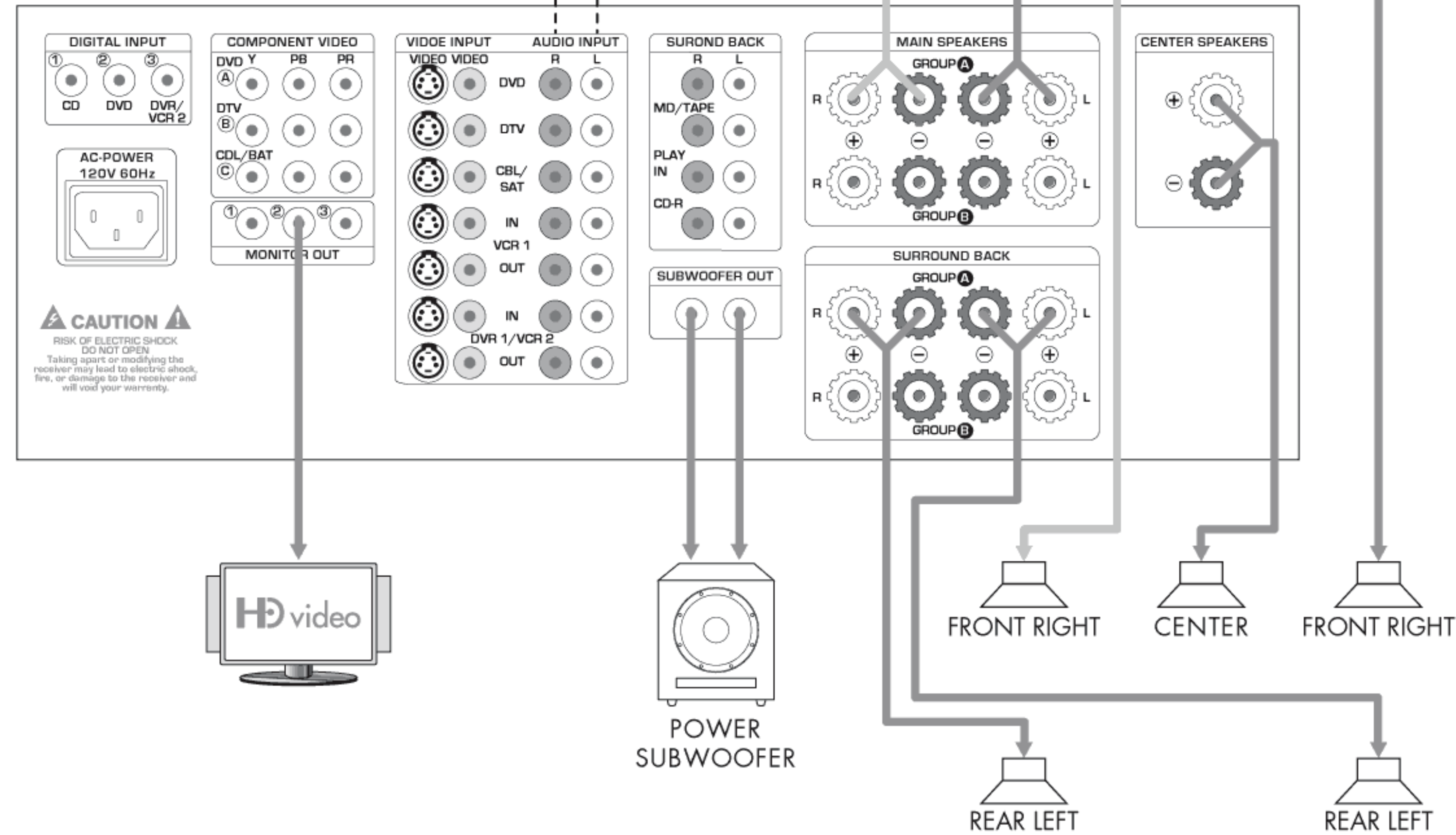

3. ROOM SIZE FROM 1,000 TO 2,000 SQUARE FEET

A mixer and a power amplifier (rated at least 1,000 watts) are connected to a pair of Karaoke speakers or a five-channel Karaoke system. Our DX-3000 mixer is great for business use such as coffee shops, restaurants or even a big living room up to 2,000 square feet. You may choose our power amplifier (DX-1500 PRO) with five speakers.

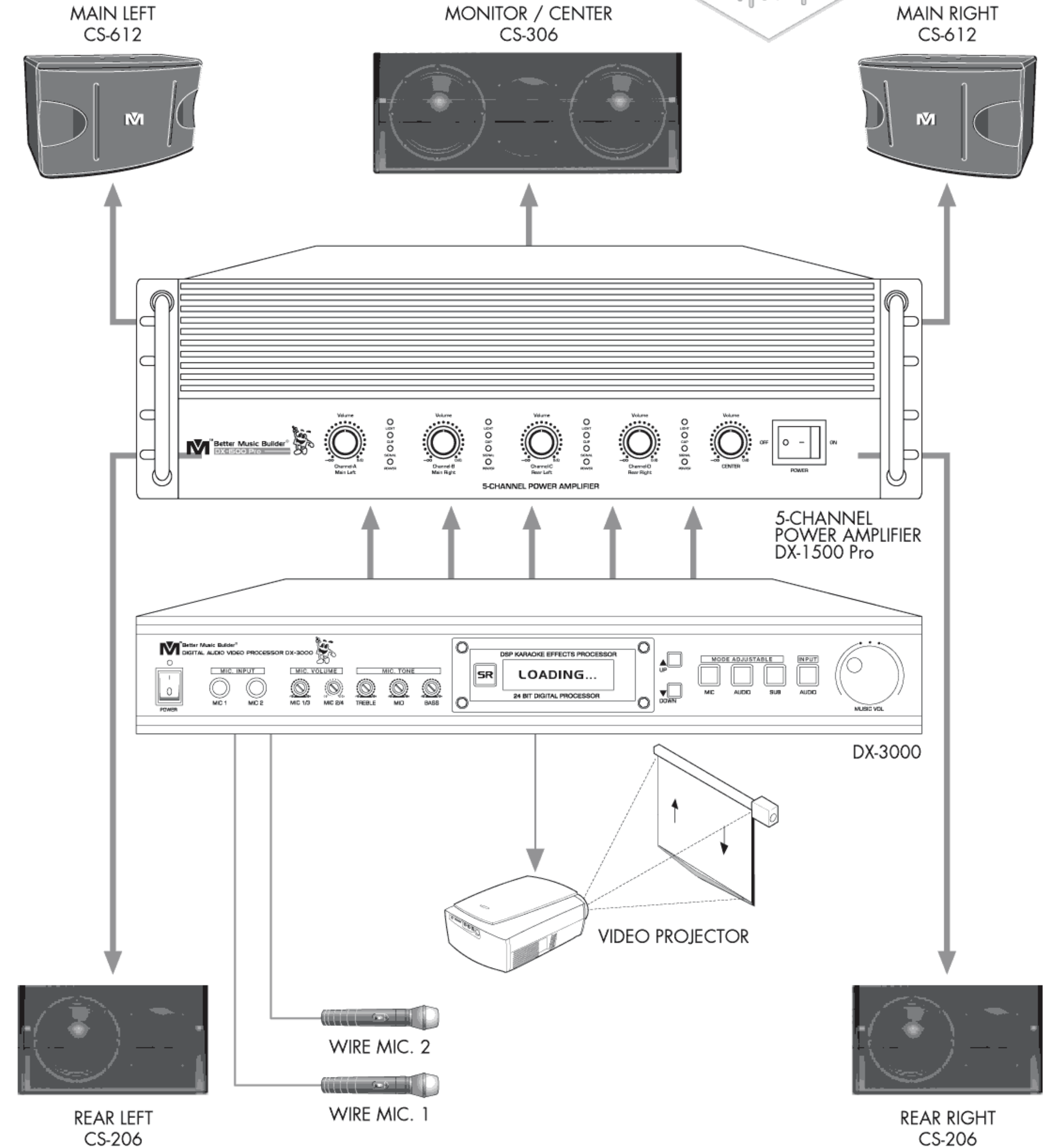
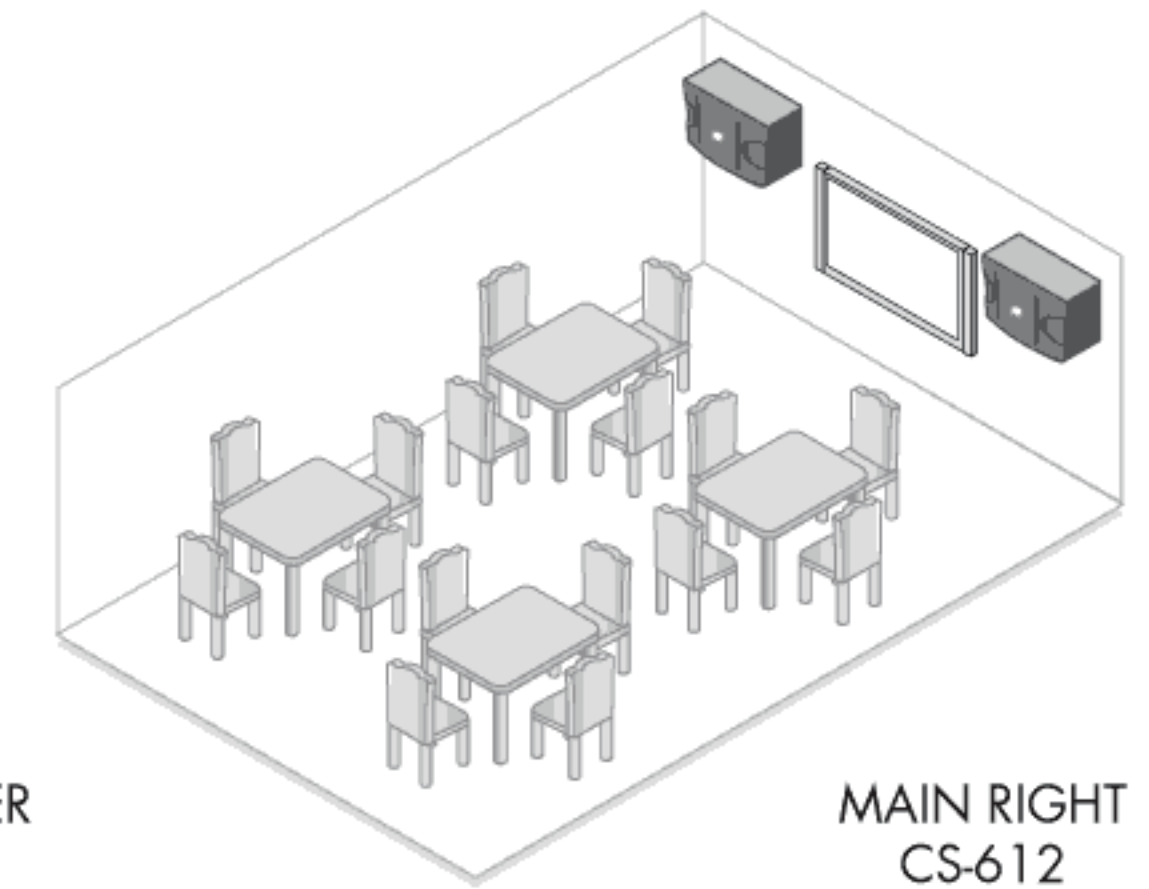

4. ROOM SIZE FROM 2,000 TO 3,000 SQUARE FEET

A mixer and three power amplifiers are connected to three pairs of Karaoke speakers.

When you use three pairs of Karaoke speakers, you need three power amplifiers (at least 1,000 watts per amplifier) for connection. Please make sure that amplifiers and speakers are at the same ohms (i.e. 8 ohms) to match each other, or it would damage your audio equipment.

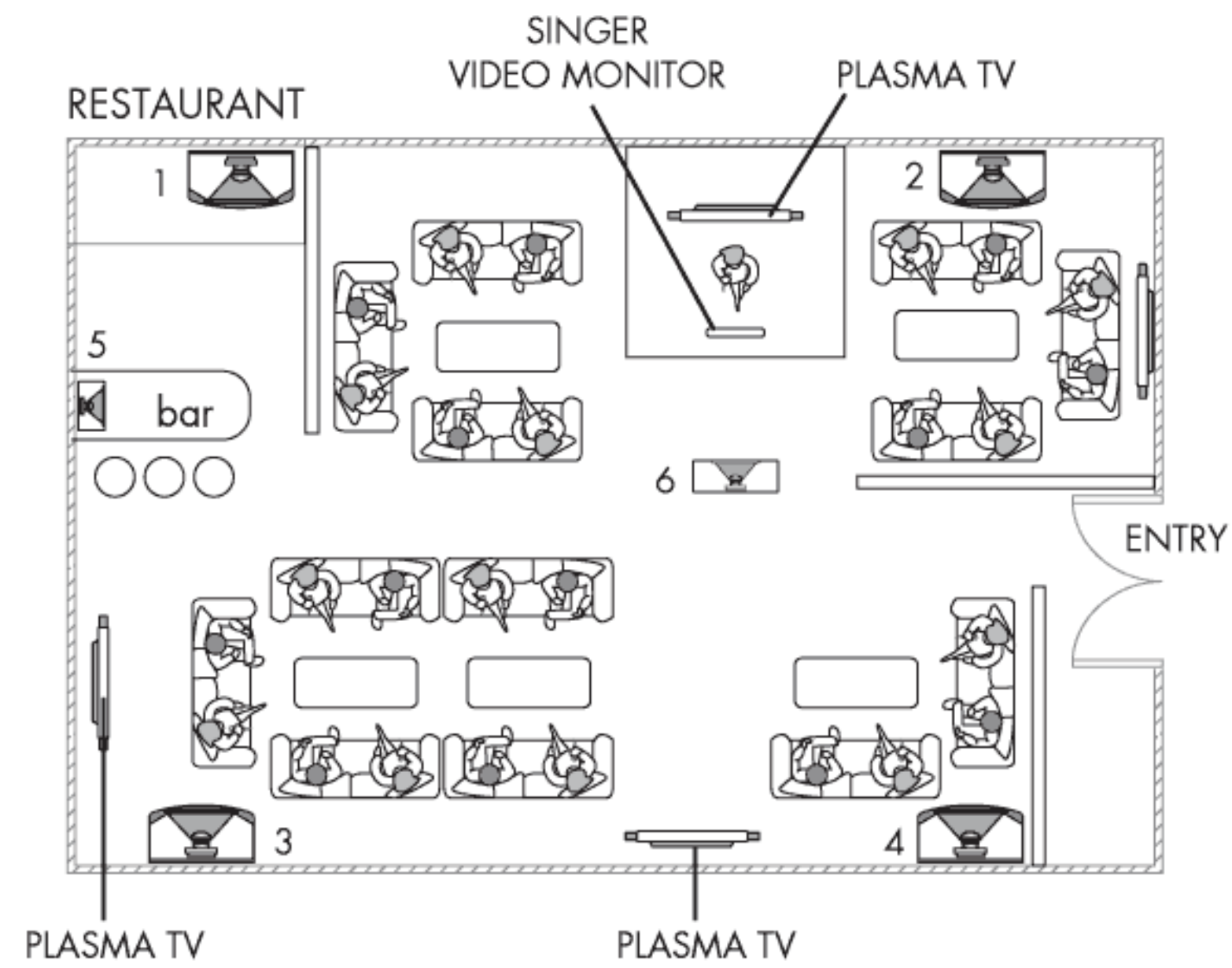

DX-3000 REAR PANEL

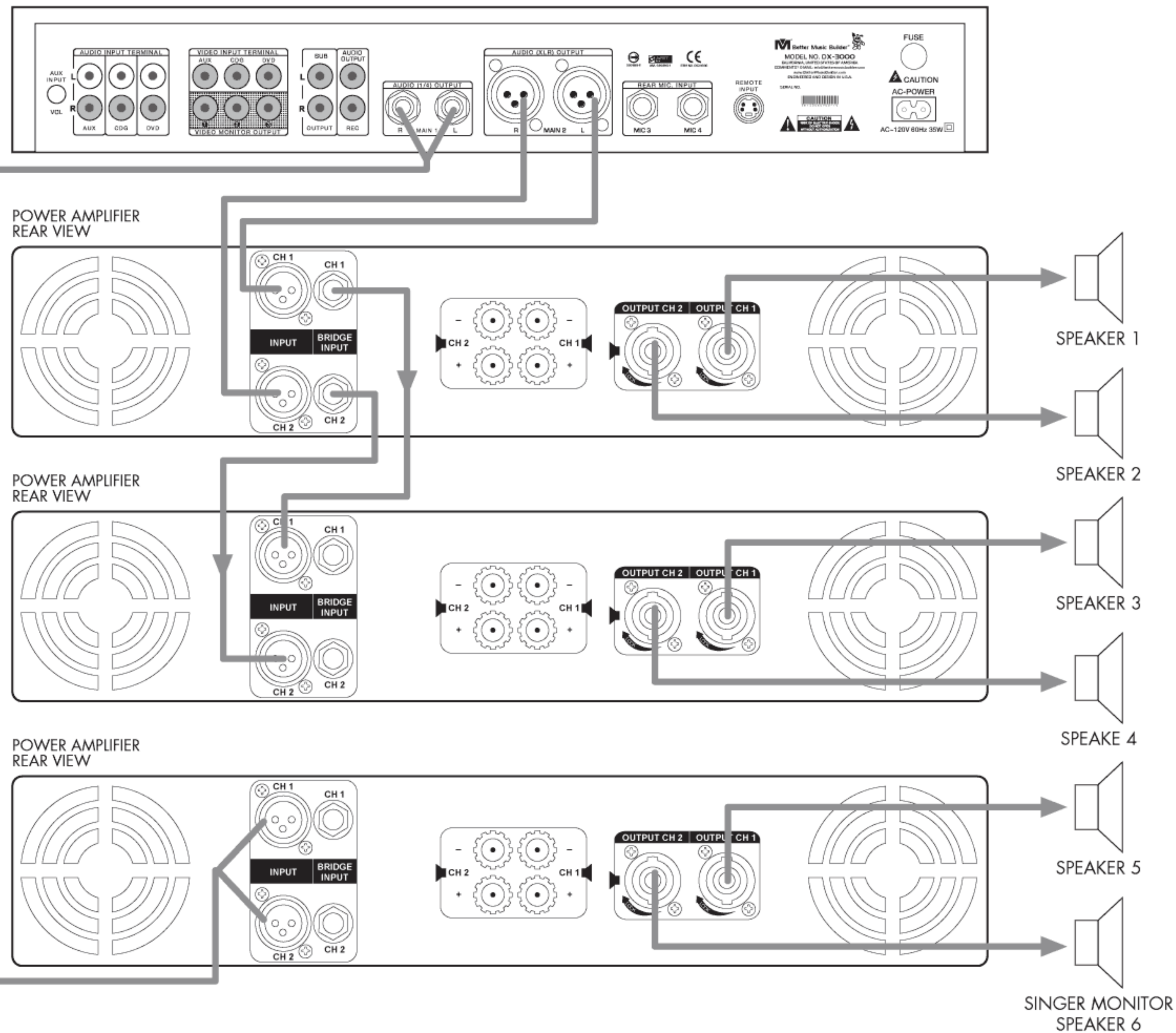

5. ROOM SIZE FROM 3,000 TO 5,000 SQUARE FEET

A mixer and six power amplifiers are connected to six pairs of Karaoke speakers.

NOTE Please refer to page 32 for different setups.

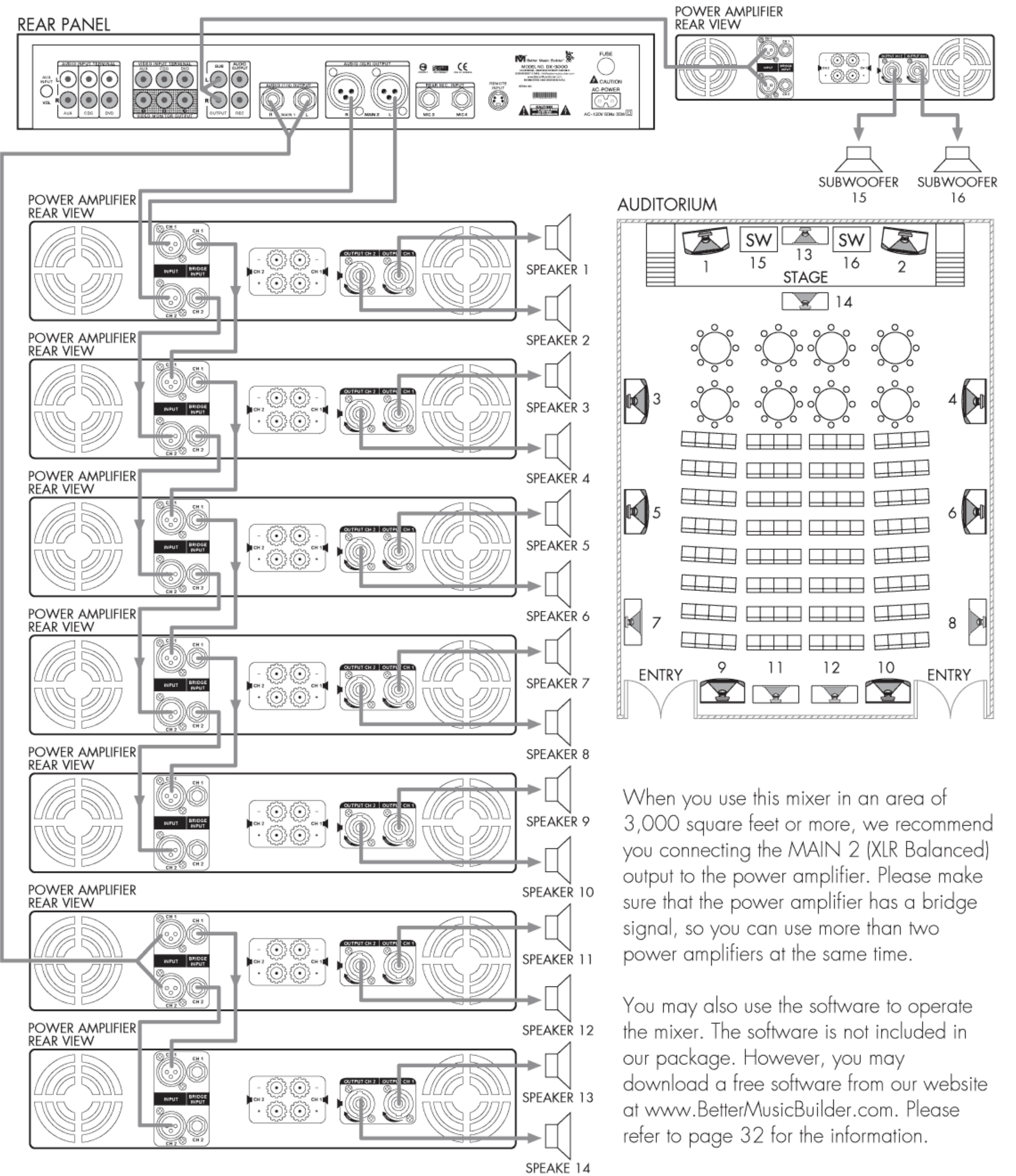

When you use this mixer in an area of 3,000 square feet or more, we recommend you connecting the MAIN 2 (XLR Balanced) output to the power amplifier. Please make sure that the power amplifier has a bridge signal, so you can use more than two power amplifiers at the same time.

You may also use the software to operate the mixer. The software is not included in our package. However, you may download a free software from our website at www.BetterMusicBuilder.com. Please refer to page 32 for the information.

5-CHANNEL CONNECTION DIAGRAM

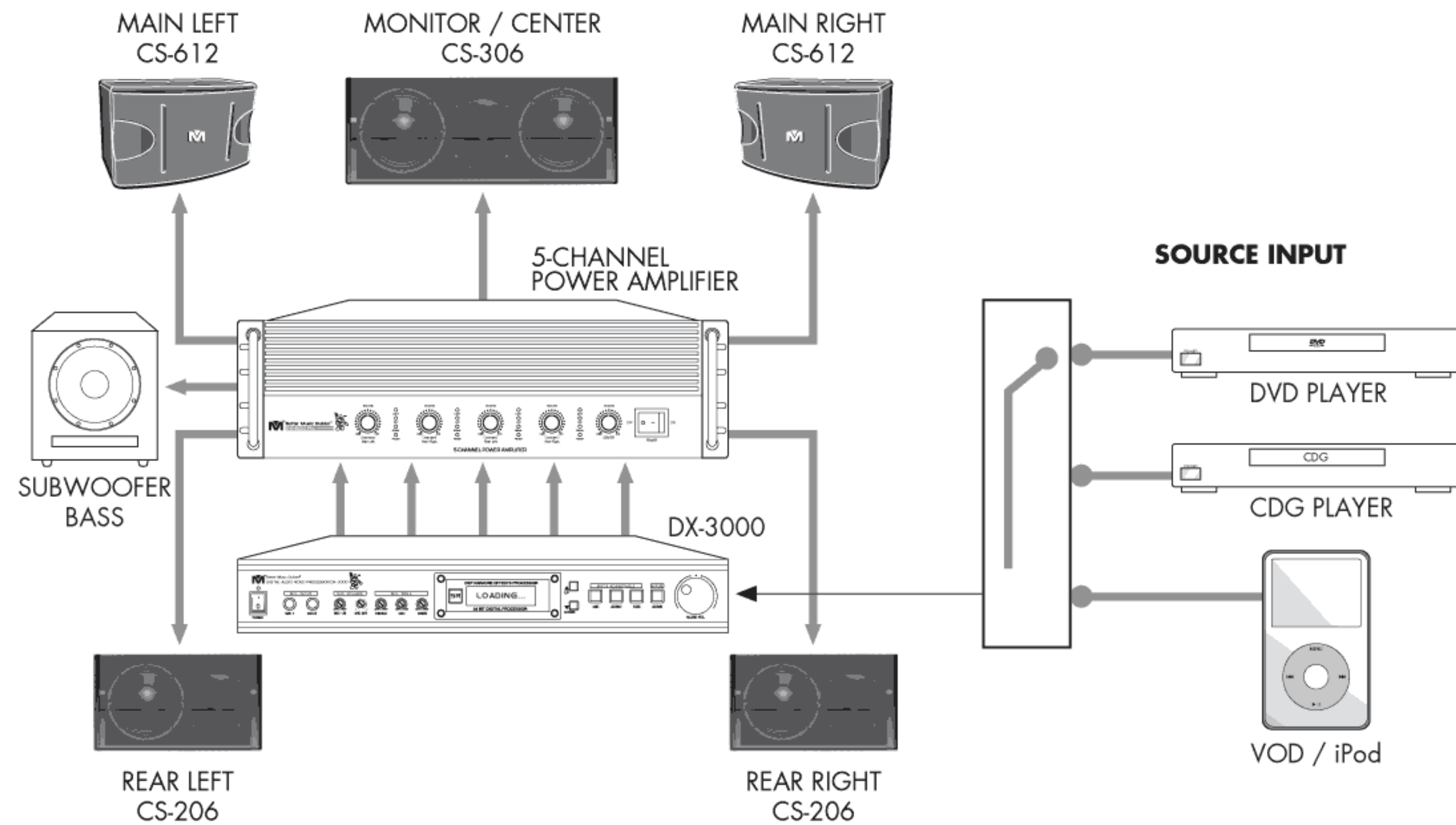

DX-3000 is a Central Processing Unit (CPU)-controlled machine with five channels to maximize the sound quality and effects. It is compatible with iPod source, so it is excellent for equipment rental. DX-3000 can also be used as a pre-amp.

DX-3000 is the second generation CPU audio/video processor with five-channel sound effects to produce the following special features.

- ❖ Five channels (pre-amp) including main speakers (right and left), center speakers, rear speakers (right and left) and subwoofer.
- ❖ Vocal from only the center speaker or from the main, rear and center speakers for singing and talking.
- ❖ Special effect adjustments (Delay, Repeat and Echo) and microphone tone adjustments to affect the output to the front, center and rear speakers. This would give you new audio experience.
- ❖ Built-in software programming with RS-232 connector to allow an external computer to operate easily.
- ❖ Three DSP factory preset vocal effects.
- ❖ Four microphone inputs.
- ❖ Special adjustment and customization for digital music key.
- ❖ Both bypassing and non-bypassing XLR balanced paths for audio signals.
- ❖ High resolution video compatible with HD Television.

DX-3000 is suitable for PA use by church, school, company conference, and café. It is excellent for Karaoke use and equipment rental.

5-CHANNEL CPU PROCESSOR

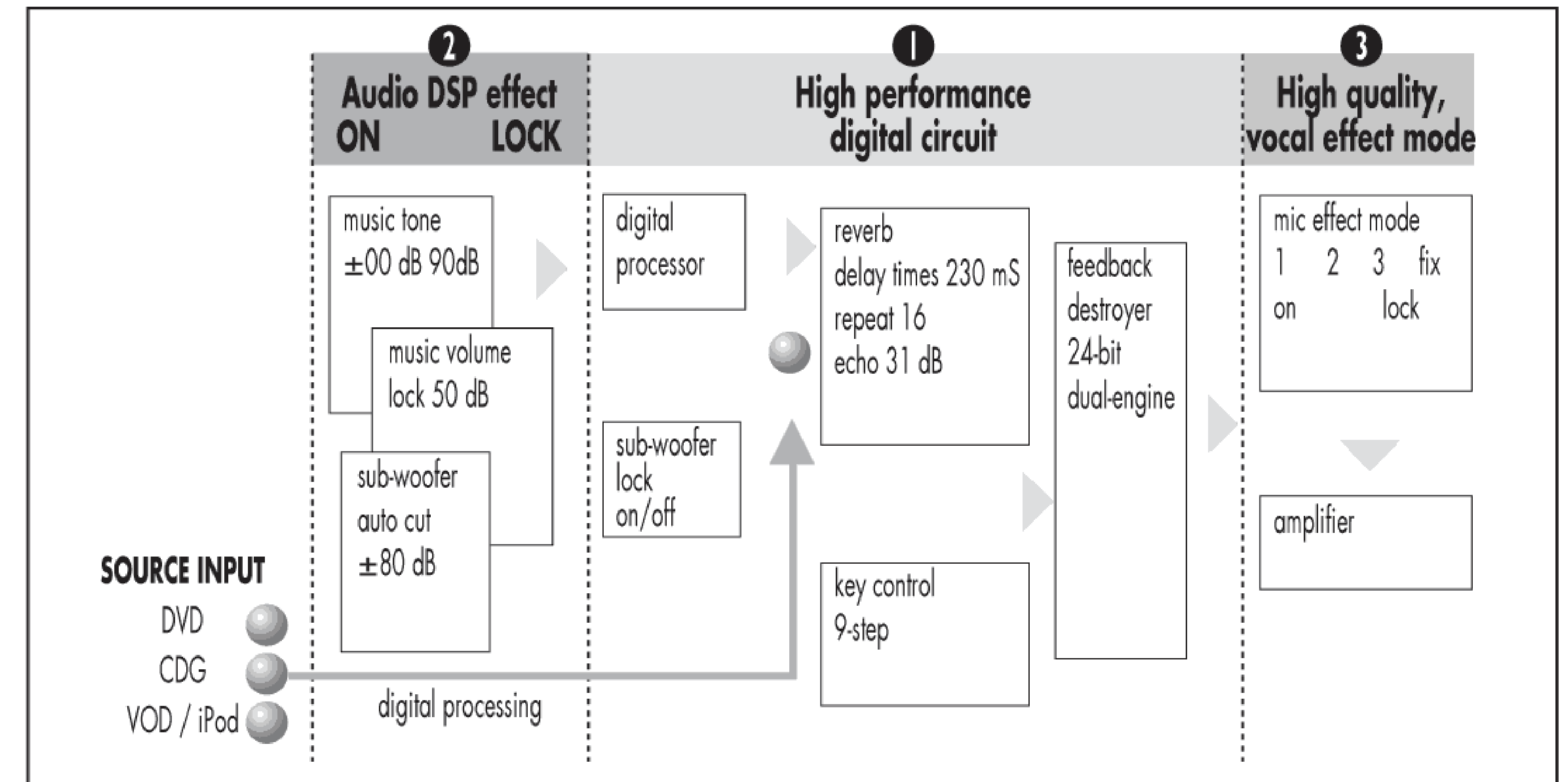

2-CHANNEL STEREO CPU PROCESSOR CONNECTION DIAGRAM

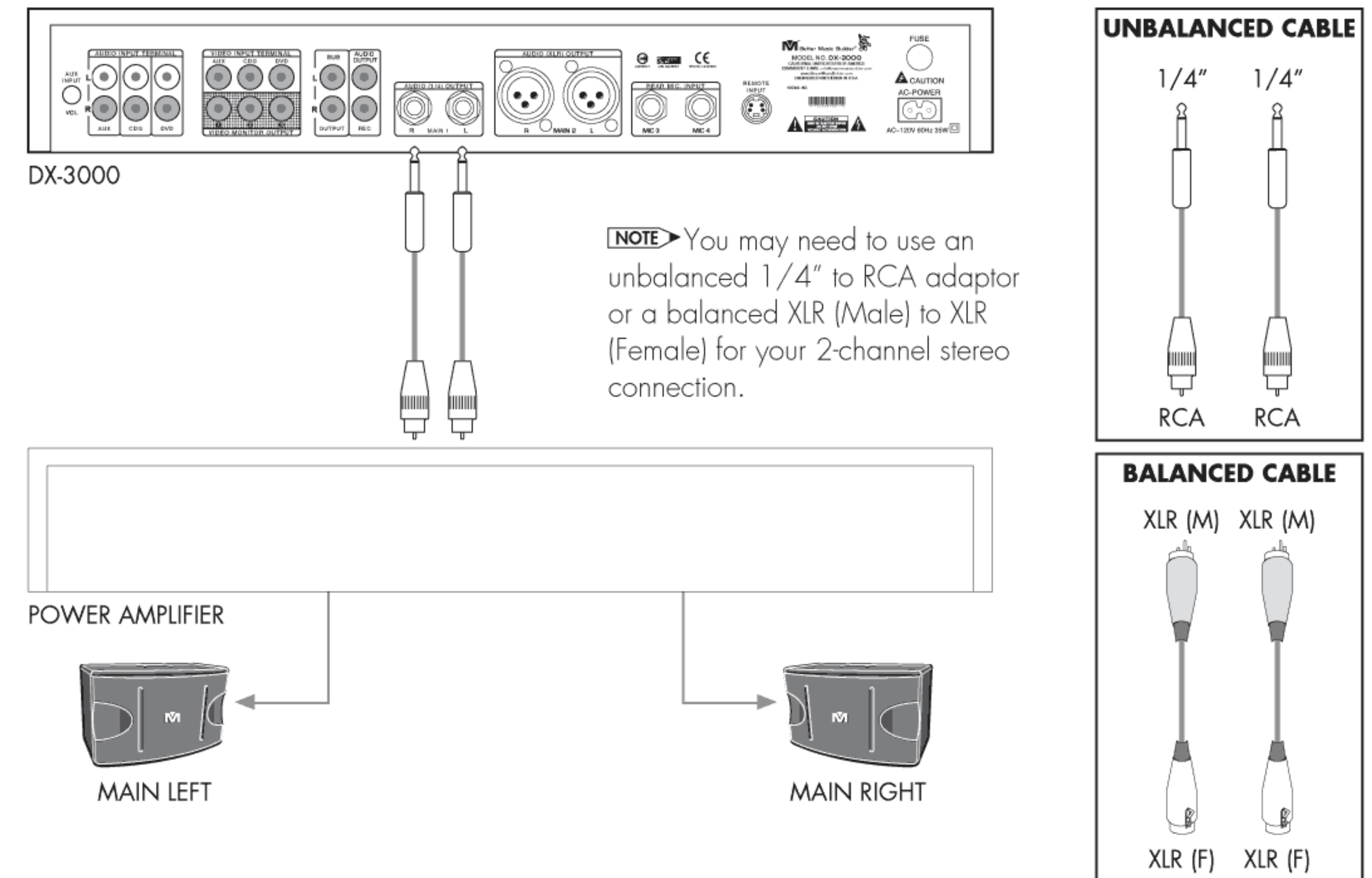

EASY INSTALLATION FOR BUSINESS

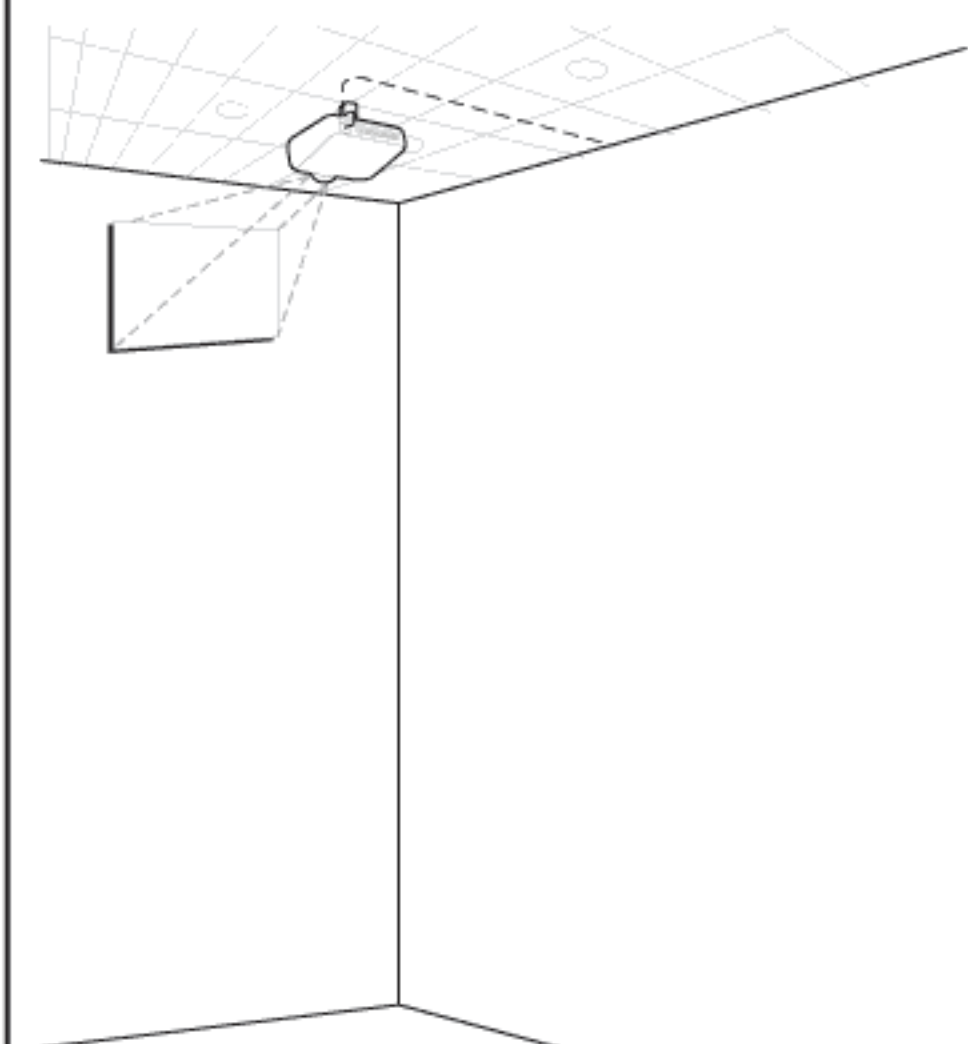

DX-3000 is a high-end audio/video processor. It can be easily installed for PA use such as church, business, café, bar, restaurant, Karaoke club, community center and nightclub, etc. because DX-3000 is a CPU-controlled pre-amp, so it is compatible with computer and iPod input.

PORTABLE

DX-3000 is a portable product, so it is excellent for equipment rental. You can mount it to a flying rack case and carry it to any place for use. DX-3000 is compatible with DVD player, CDG player, and VOD ,MP3, or iPod>. Since DX-3000 is a pre-amplifier, you may choose to use a 2-channel power amplifier or a 5-channel power amplifier. We recommend you to use our CS-306 full-range loud speakers when using a subwoofer. It would be an excellent match.

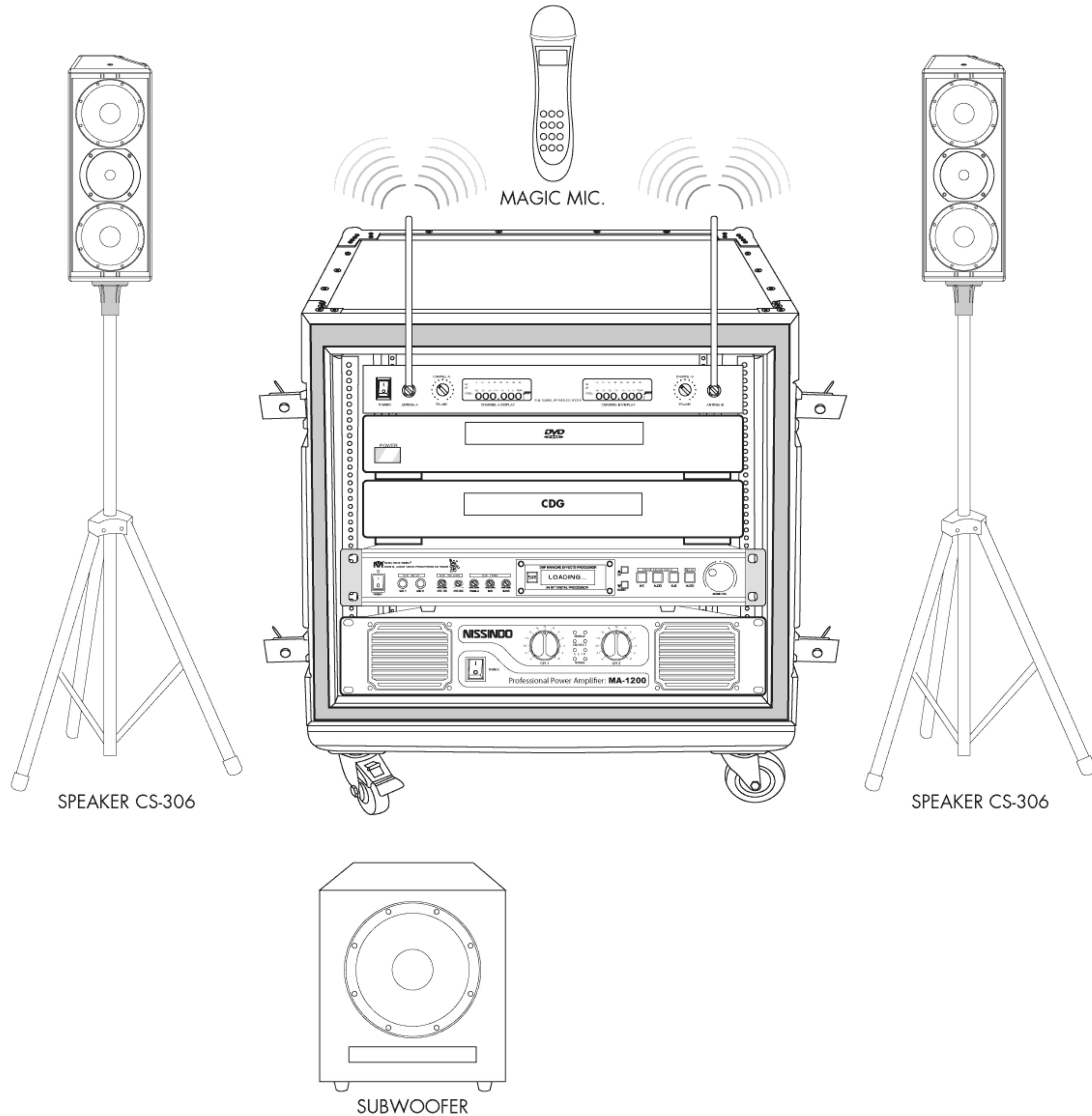

HOW TO CONNECT RECORDER & SUB WOOFER

AUX 1 and AUX 2: These two audio-outs bypass the circuit for music and mic. tones. Any adjustment on toning would not affect the original signal for recording.

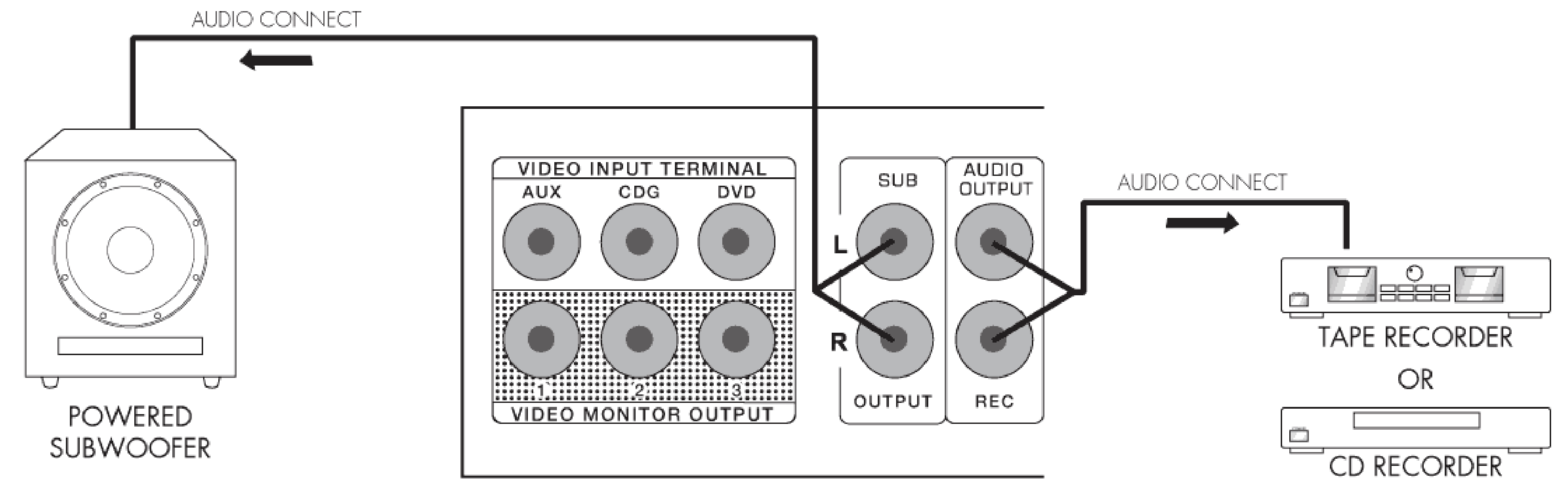

HOW TO CONNECT MUSIC A.V. SOURCE AND VIDEO MONITOR

Before you connect the source (i.e. DVD, CDG and AUX Karaoke), you should turn off the power for all machine, so it would protect you from electric shock and prevent the equipment from damage. To connect the AV source, the first thing to do is to connect the audio source to the amplifier input. Then, you can connect the video source. Please refer to the following diagram. To ensure high quality sound and video, we recommend using high quality cables. To learn more about high quality cable, please refer to page 32.

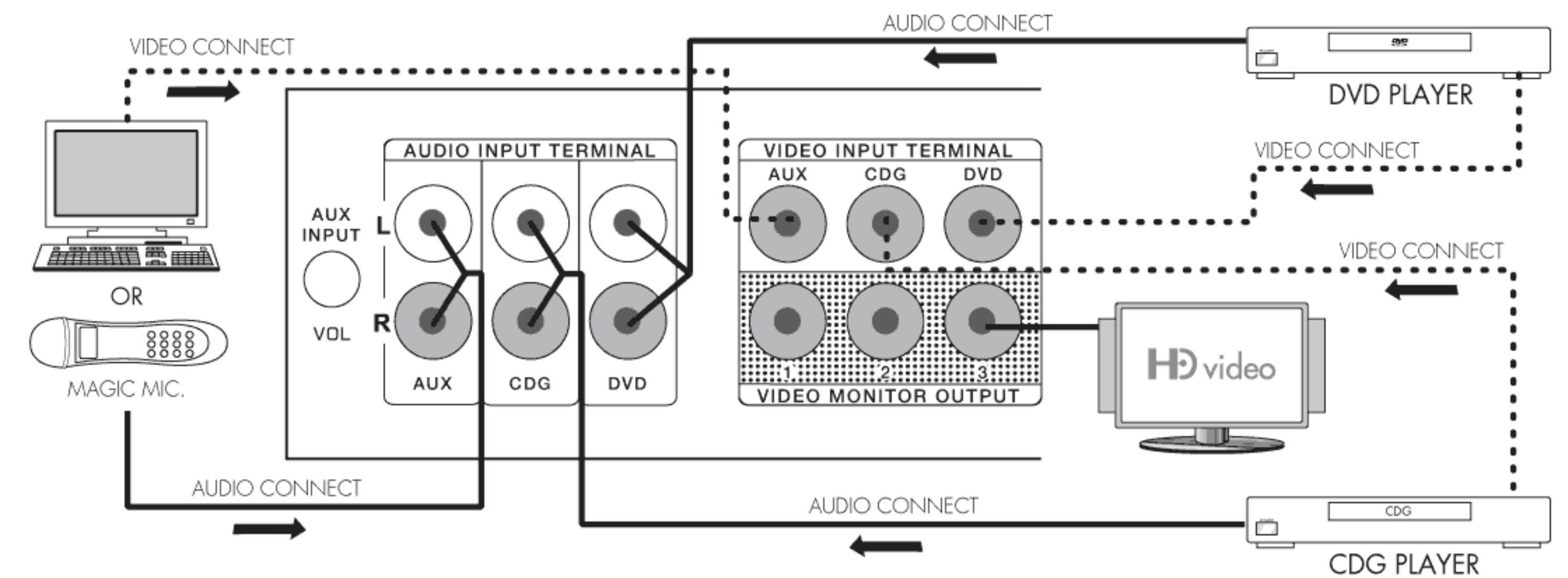

Y-VIDEO ADAPTER



NOTE If you need more than two Video-Out, you may need a Y-adaptor for connection. However, it may lose the video signal if it extends over 12 feet. In this case, we recommend you to use a video signal amplifier to maintain good video quality.

HOW TO CONNECT TO AN AMPLIFIER for 2-CHANNEL STEREO

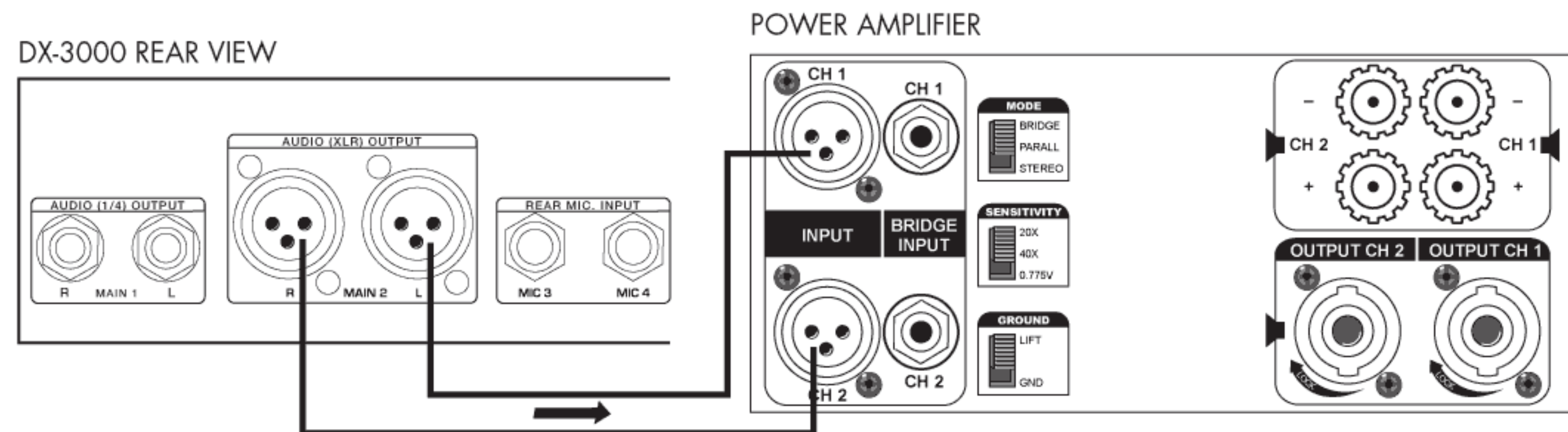

High quality connection uses XLR cable to connect

HOW TO CONNECT TO AN AMPLIFIER for 5-CHANNEL OUTPUT

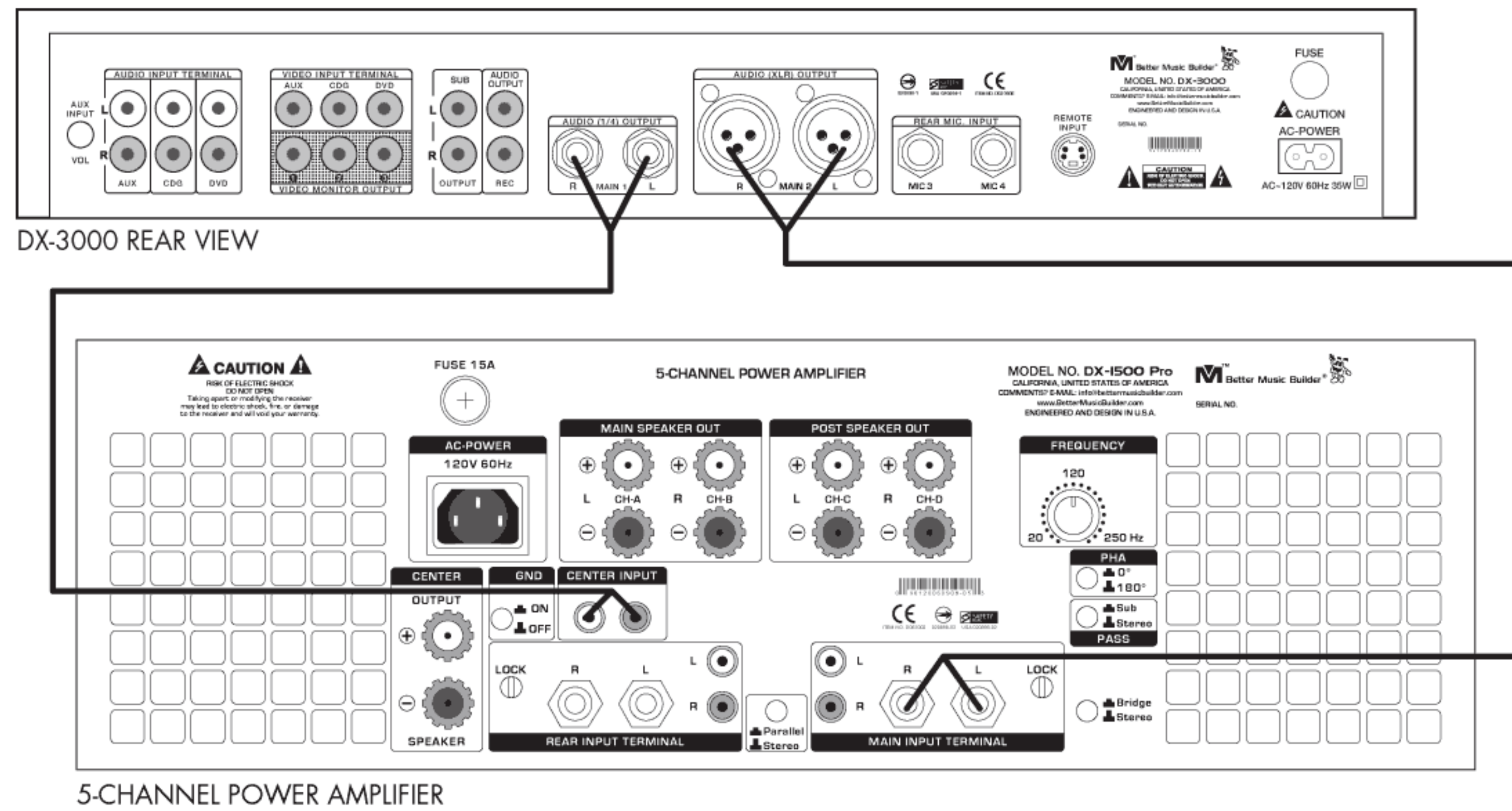

HOW TO CONNECT HIGH DEFINITION VIDEO

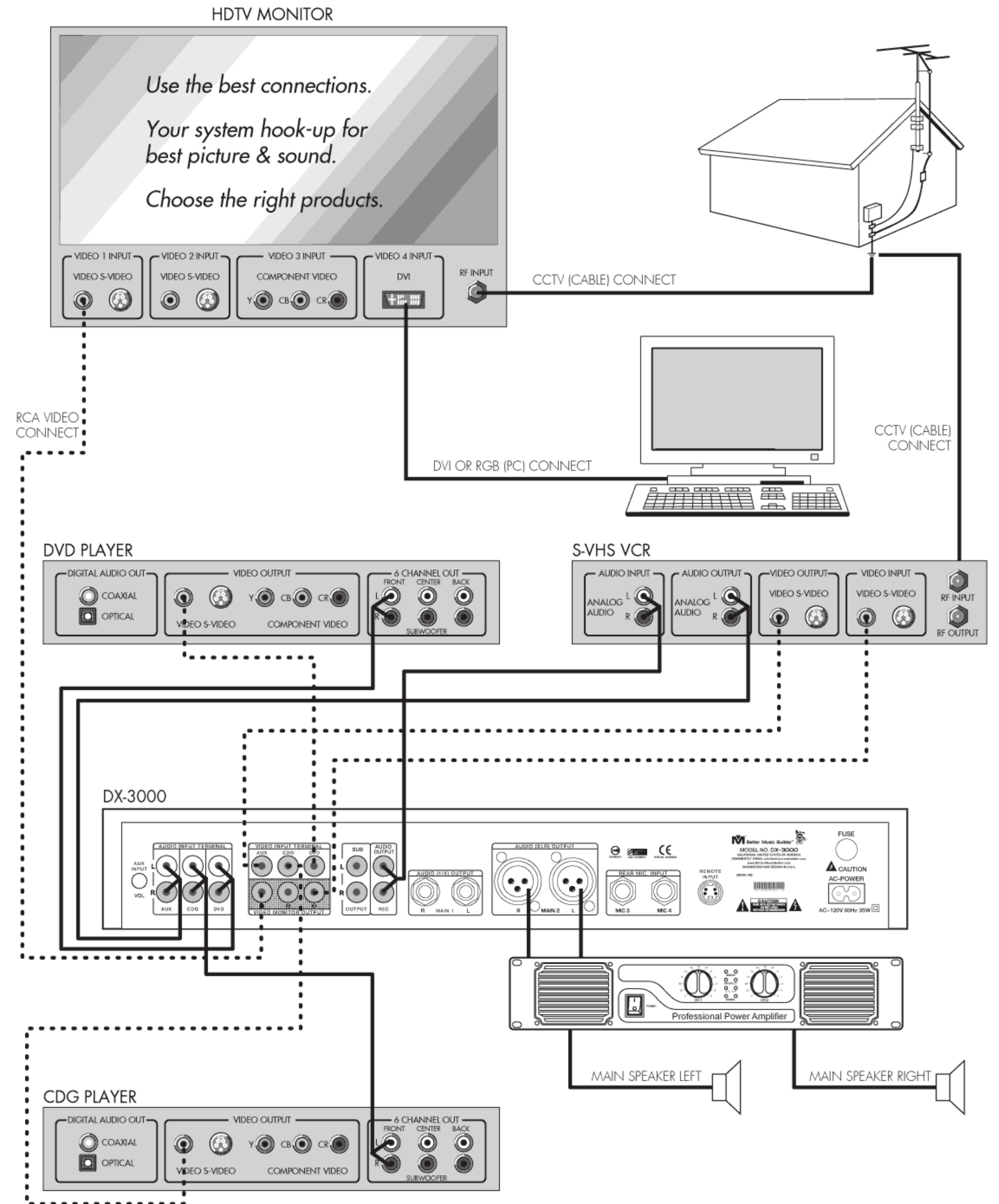

HOW TO CONNECT HDTV

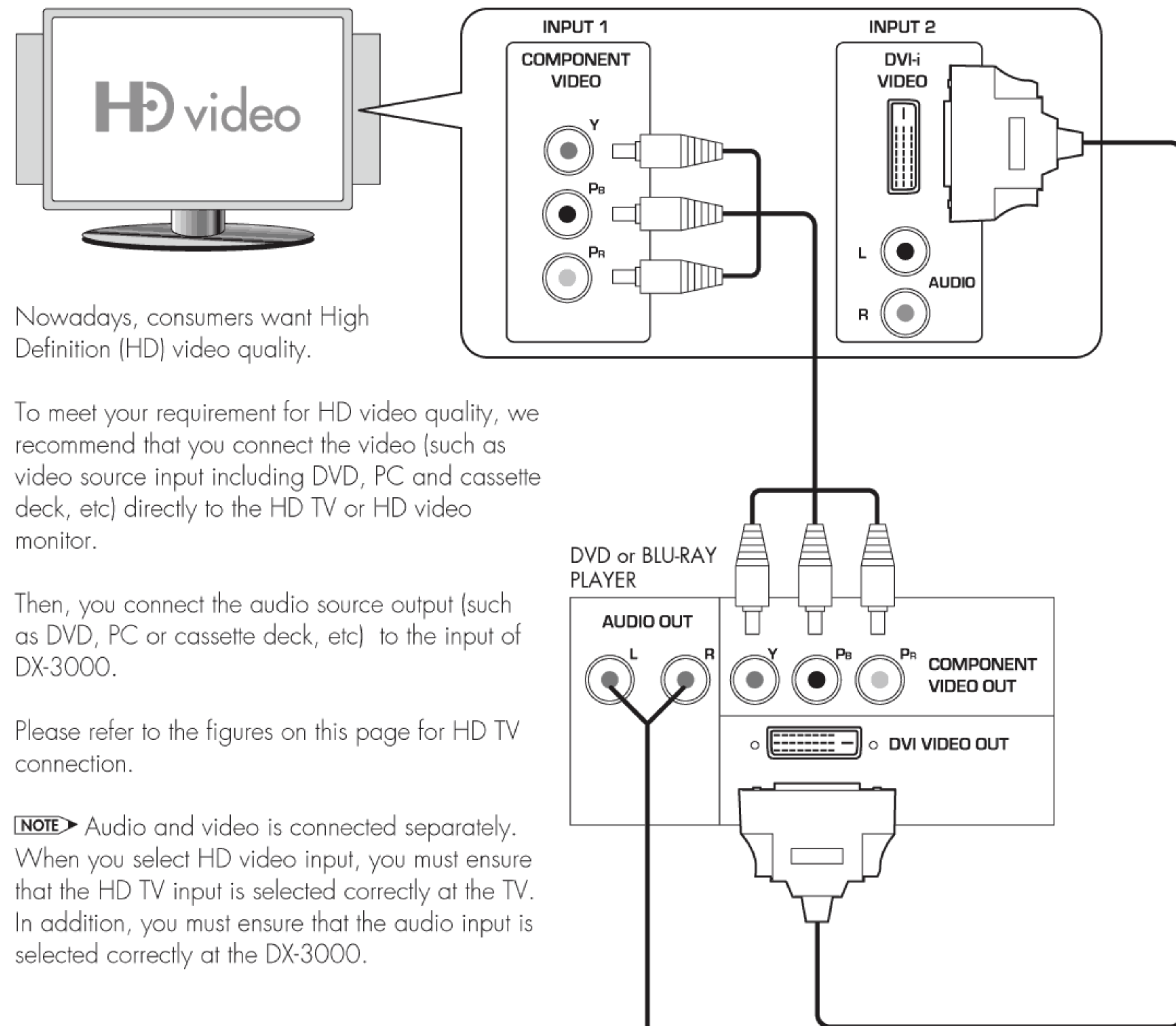

Nowadays, consumers want High Definition (HD) video quality.

To meet your requirement for HD video quality, we recommend that you connect the video (such as video source input including DVD, PC and cassette deck, etc) directly to the HD TV or HD video monitor.

Then, you connect the audio source output (such as DVD, PC or cassette deck, etc) to the input of DX-3000.

Please refer to the figures on this page for HD TV connection.

NOTE Audio and video is connected separately. When you select HD video input, you must ensure that the HD TV input is selected correctly at the TV. In addition, you must ensure that the audio input is selected correctly at the DX-3000.

DX-3000 REAR VIEW

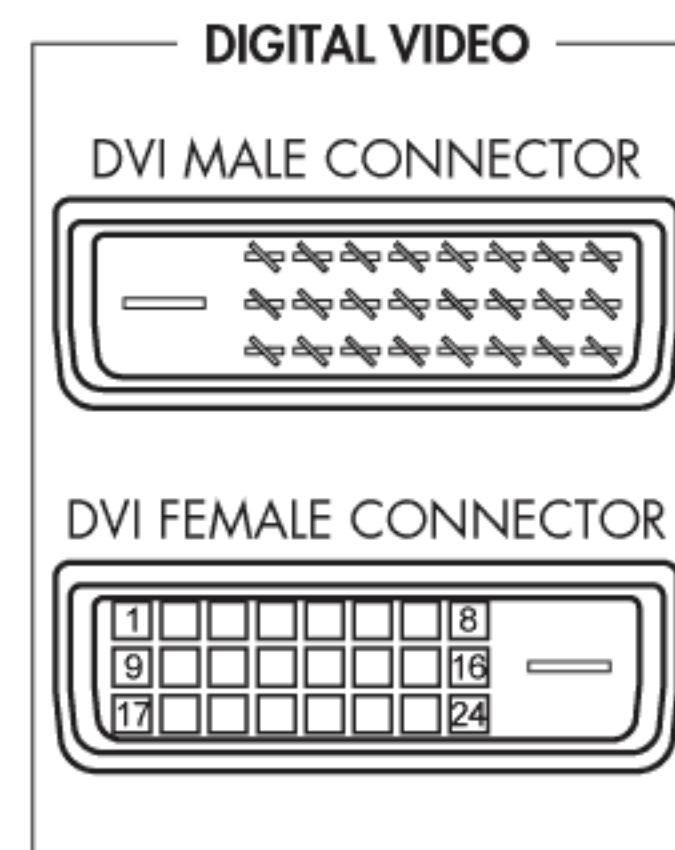
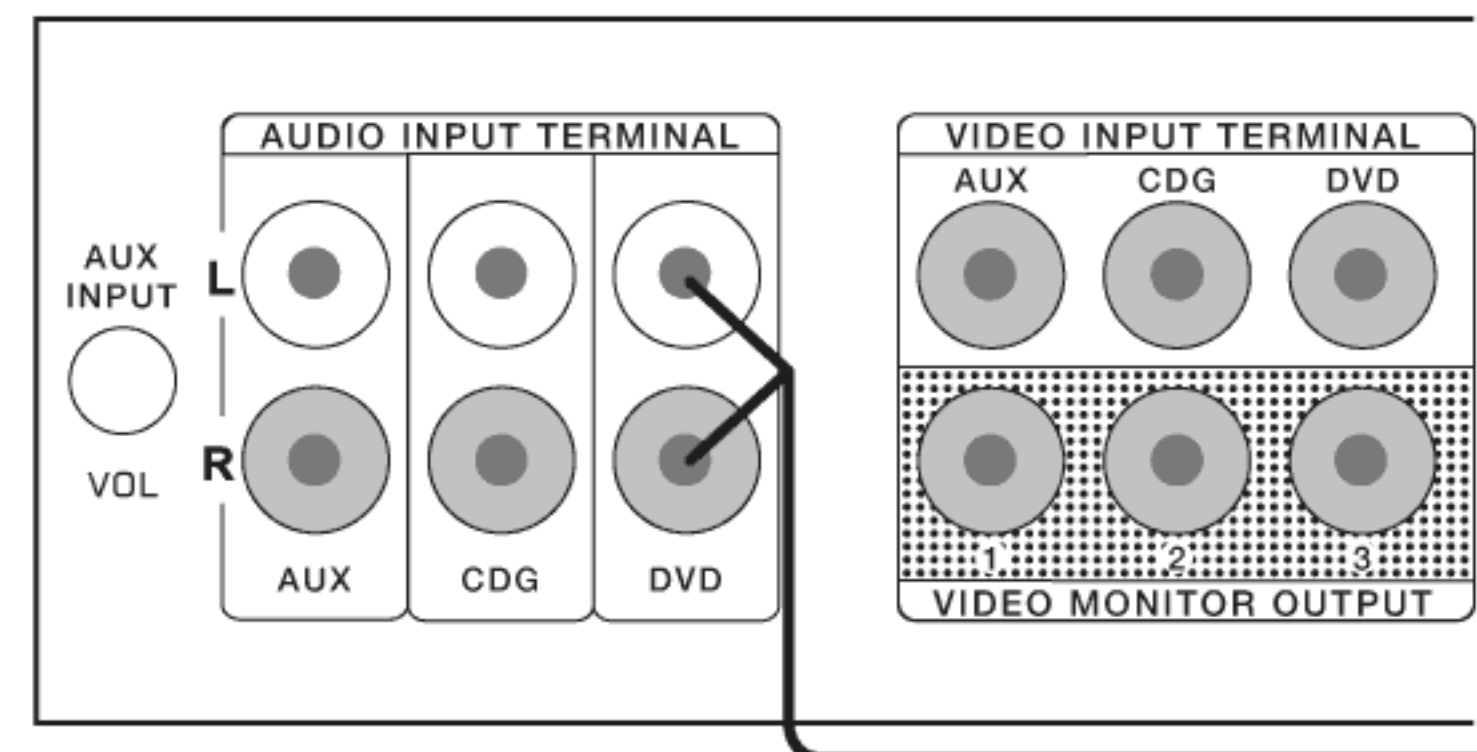

DVI and HDMI connection

Digital Video for high performance, ideal for connecting digital video signal source to digital signal processing distribution and display.

HOW TO CONNECT MICROPHONE

FRONT PANEL

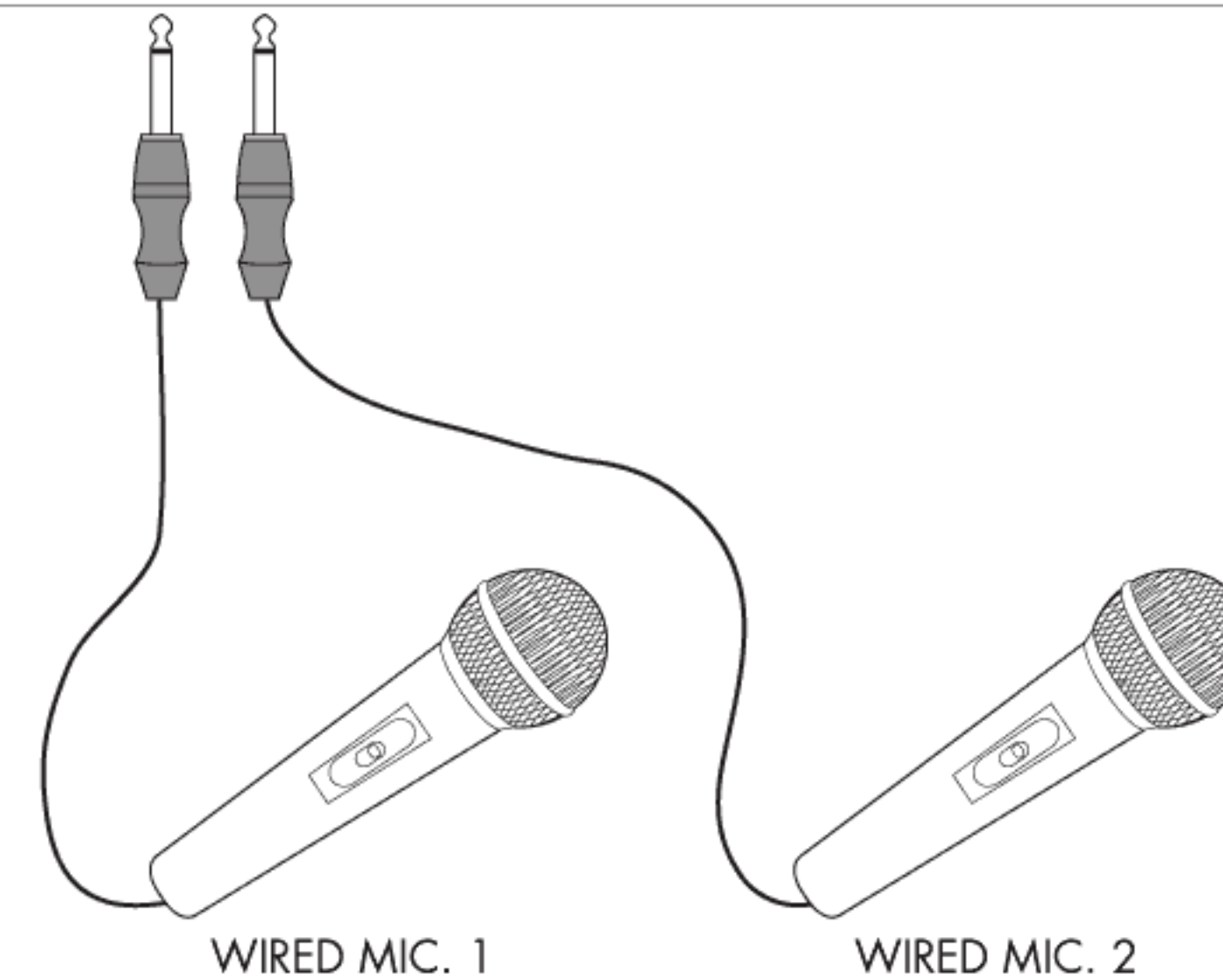
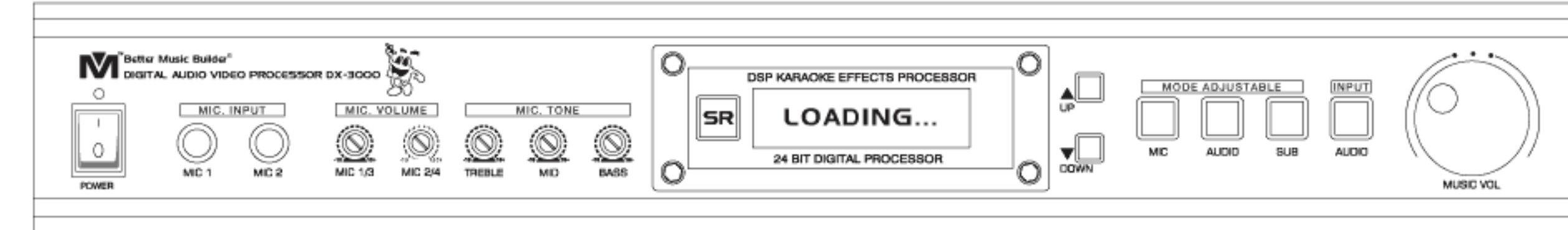

NOTE

Adjust Mic Master Volume to 0 dB before inserting 1/4" microphone plugs into mic inputs to avoid unpleasant noise and protect your equipment from damage.

REAR PANEL

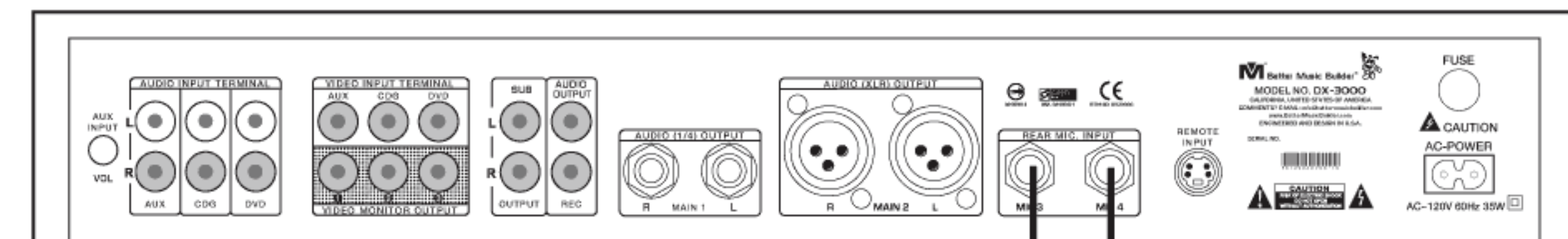

WIRELESS MICROPHONE RECEIVER

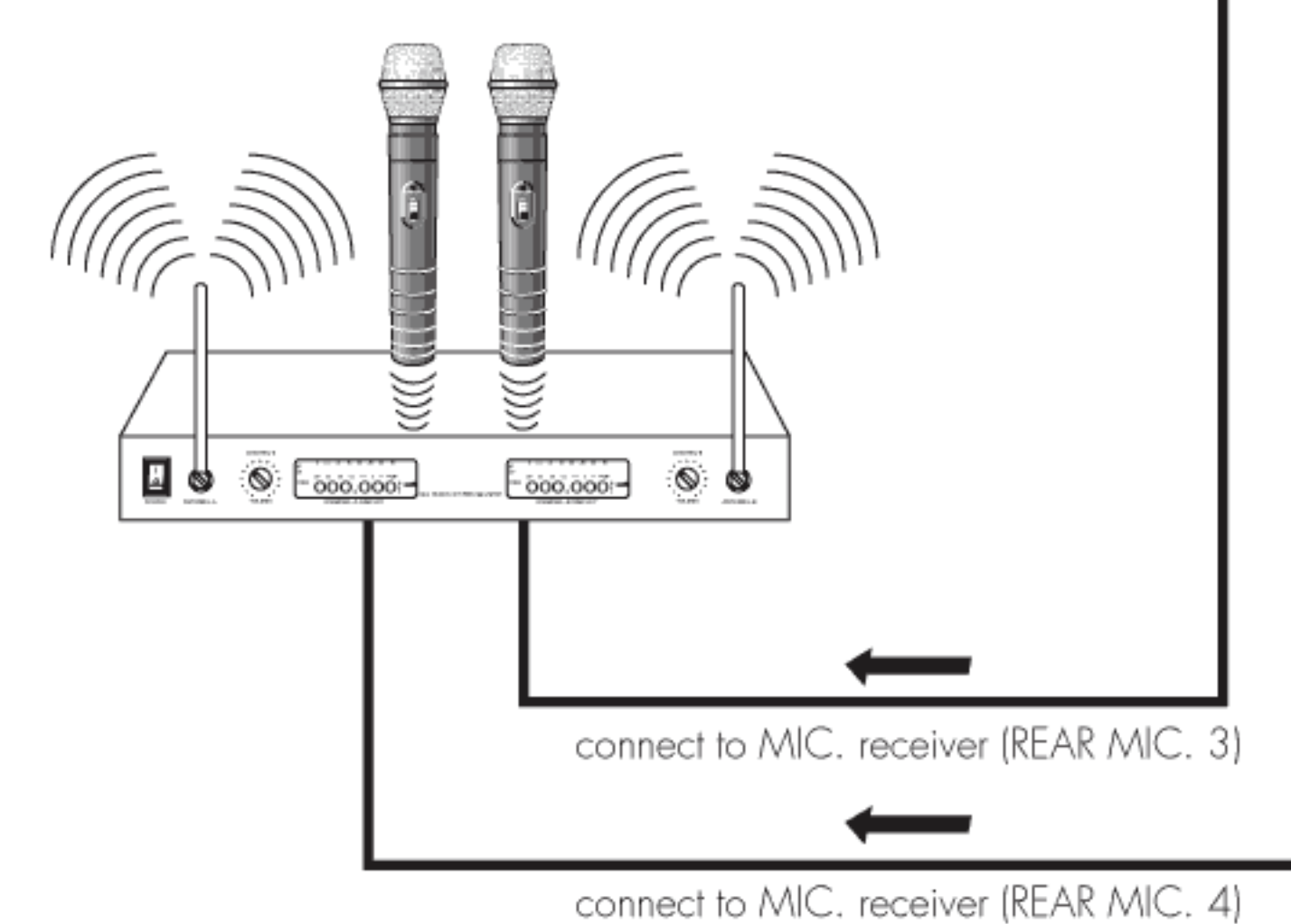

connect to MIC. receiver (REAR MIC. 3)

connect to MIC. receiver (REAR MIC. 4)

OPERATING INSTRUCTIONS

1. Turn on the DX-3000 by flipping the power switch to the ON (I) position.

2. After turning the machine on, it takes about 40 seconds to boot it up for operation.

3. After the machine has been booted up, the Digital Display (VFD) would appear as follows:

MUSIC INPUT

4. Press the AUDIO INPUT button to select the source as follows:

This machine is specially designed for Karaoke business and in such a way that DVD has the first priority for input selection. When nobody is singing Karaoke in the room, the machine would turn to commercial advertising. When someone wants to sing, the machine would return to DVD (Karaoke mode with the first priority).

For input selection, press the INPUT/SELECT button to move the arrow to select the source: DVD, AUX or CDG. DVD has the first priority; AUX and CDG have the second and the lowest priorities respectively. That's why the machine always chooses DVD after power is up. If you want to select CDG you have to turn off the source connected to DVD. For example, in a karaoke bar, CDG can be used to play background music while DVD is connected to the main mixer where the microphones are plugged in. When the DJ makes an announcement through the microphone, the built-in CPU will automatically select DVD and you will not hear the background music. Instead, you will only hear the DJ's voice or whatever signal source (for example, commercial advertising) is plugged into the main mixer. You may learn more on DVD from page 32 under "DVD Connection for Home" and 33 under "DVD Connection for Commercial."

5. Memory

Press the memory button to save your favorite settings for SUB, AUDIO and MIC modes and MUSIC VOLUME. You must press it immediately after you make adjustment to each and every said setting if you want to store it in memory. When you make an adjustment and press memory the screen will display as below:

DATA STORE
Processing...OK!

MODE ADJUSTABLE (MIC, AUDIO, SUB)

6. Selectable Modes

There are three different modes: SUB (Subwoofer), AUDIO and MIC (microphone). Press the SUB, AUDIO or MIC button to select the mode you want.

SUB Mode:

❖ Adjust subwoofer mode by pressing the SUB button.

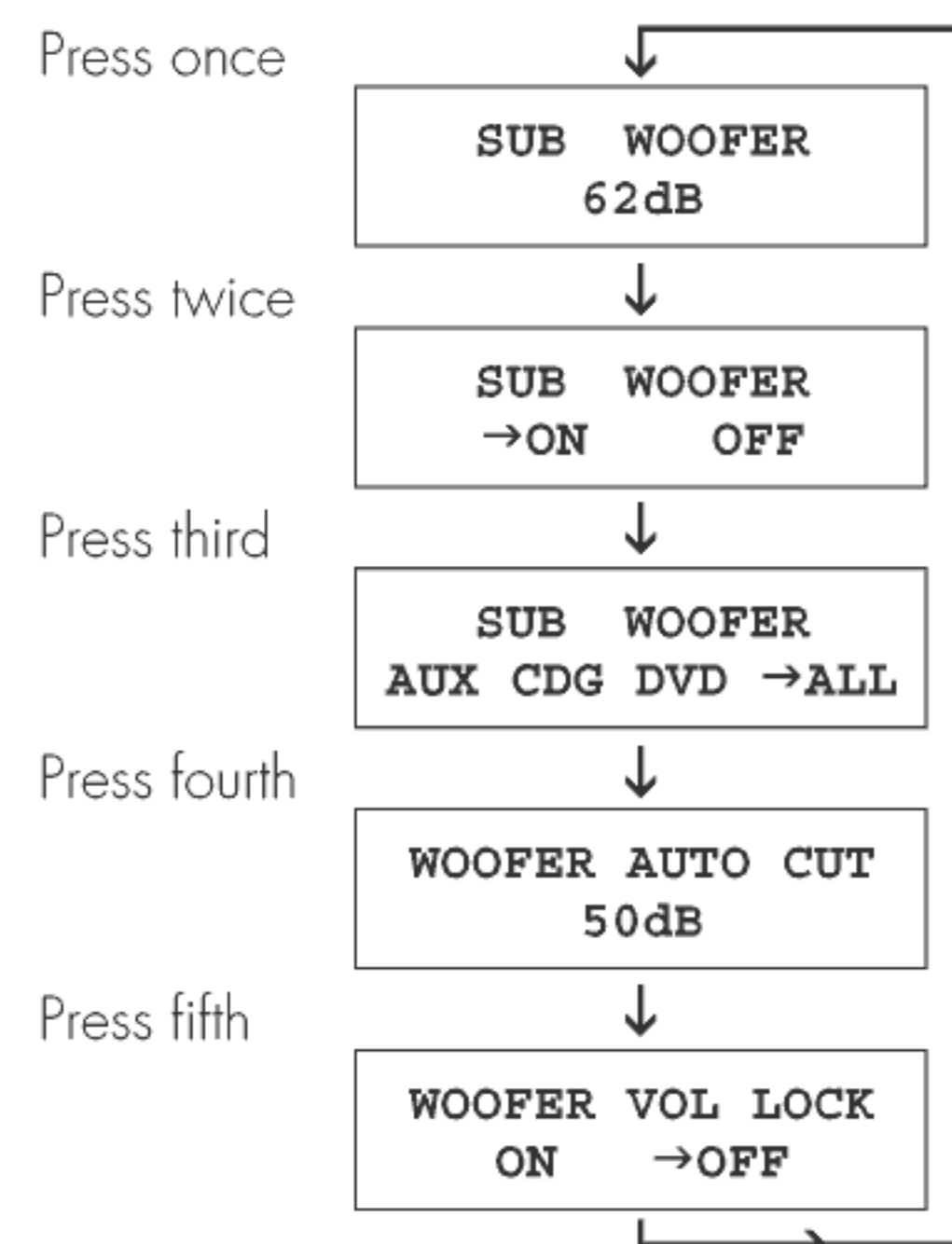

A. Press the SUB button for the first time, the Digital Display would appear as follows:

SUB WOOFER
80dB

NOTE Press the UP/DOWN button to adjust the subwoofer volume. Range: 00dB to 80dB.

B. Press the SUB button the second time, the Digital Display would appear as follows:

SUB WOOFER
→ON OFF

NOTE Press the UP/DOWN button to move the arrow to select ON or OFF. (The subwoofer will be deactivated in off position).

C. Press the SUB button the third time, the Digital Display would appear as follows:

SUB WOOFER
AUX CDG DVD →ALL

NOTE Press the UP/DOWN button to move the arrow to select AUX, CDG, DVD or ALL. (The subwoofer will be activated for the selected input source only)

D. Press the SUB button the fourth time, the Digital Display would appear as follows:

WOOFER AUTO CUT
80dB

NOTE Press the UP/DOWN button to limit the subwoofer at a designated level. You may select from 00dB up to maximum 80dB.

E. Press the SUB button the fifth time, the Digital Display would appear as follows:

WOOFER VOL LOCK
ON →OFF

NOTE Press the UP/DOWN button to move the arrow to select ON or OFF. Once you have selected ON, all SUB mode settings can't be changed.

AUDIO Mode:

❖ Select the audio mode by pressing the AUDIO button.

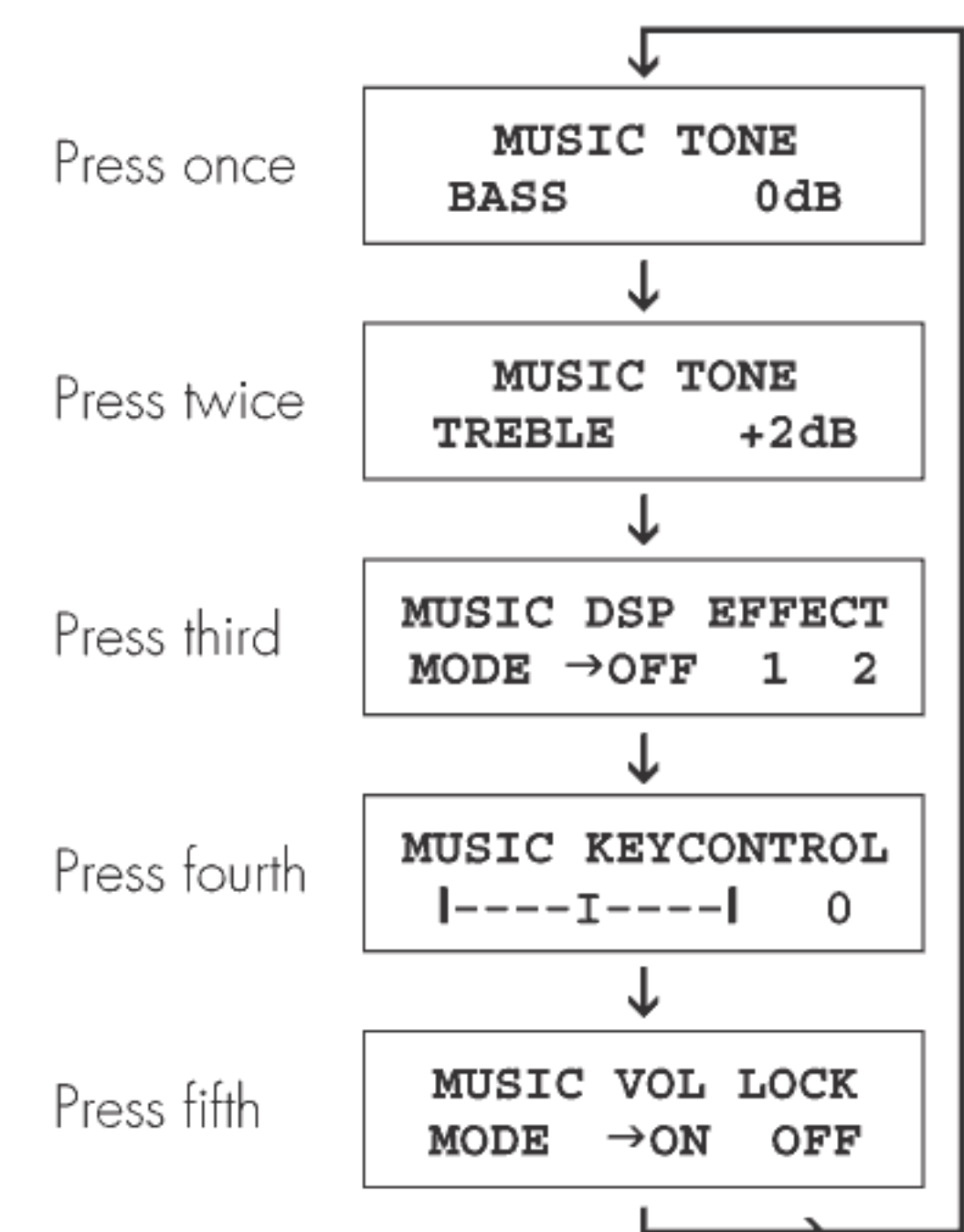

A. Press the AUDIO button for the first time, the Digital Display would appear as follows:

MUSIC TONE
BASS 0dB

NOTE Press the UP/DOWN button to adjust the bass. Range: -10dB to +10dB.

B. Press the AUDIO button for the second time, the Digital Display would appear as follows:

MUSIC TONE
TREBLE +2dB

NOTE Press the UP/DOWN button to adjust the treble. Range: -10dB to +10dB.

C. Press the AUDIO button for the third time, the Digital Display would appear as follows:

MUSIC DSP EFFECT
MODE →OFF 1 2

NOTE Press the UP/DOWN button to move the arrow to select the mode: OFF, 1 or 2. "1" is to simulate disco; "2" is to simulate hall.

D. Press the AUDIO button for the fourth time, the Digital Display would appear as follows:

MUSIC KEYCONTROL
|----I----| 0

NOTE Press the UP/DOWN button to adjust the 9-step key level.

E. Press the AUDIO button for the fifth time, the Digital Display would appear as follows:

MUSIC VOL LOCK
MODE →ON OFF

NOTE Press the UP/DOWN button to turn the music volume lock on or off. When ON audio settings can't be changed.

MIC Mode:

❖ Select the microphone mode by pressing the MIC button.

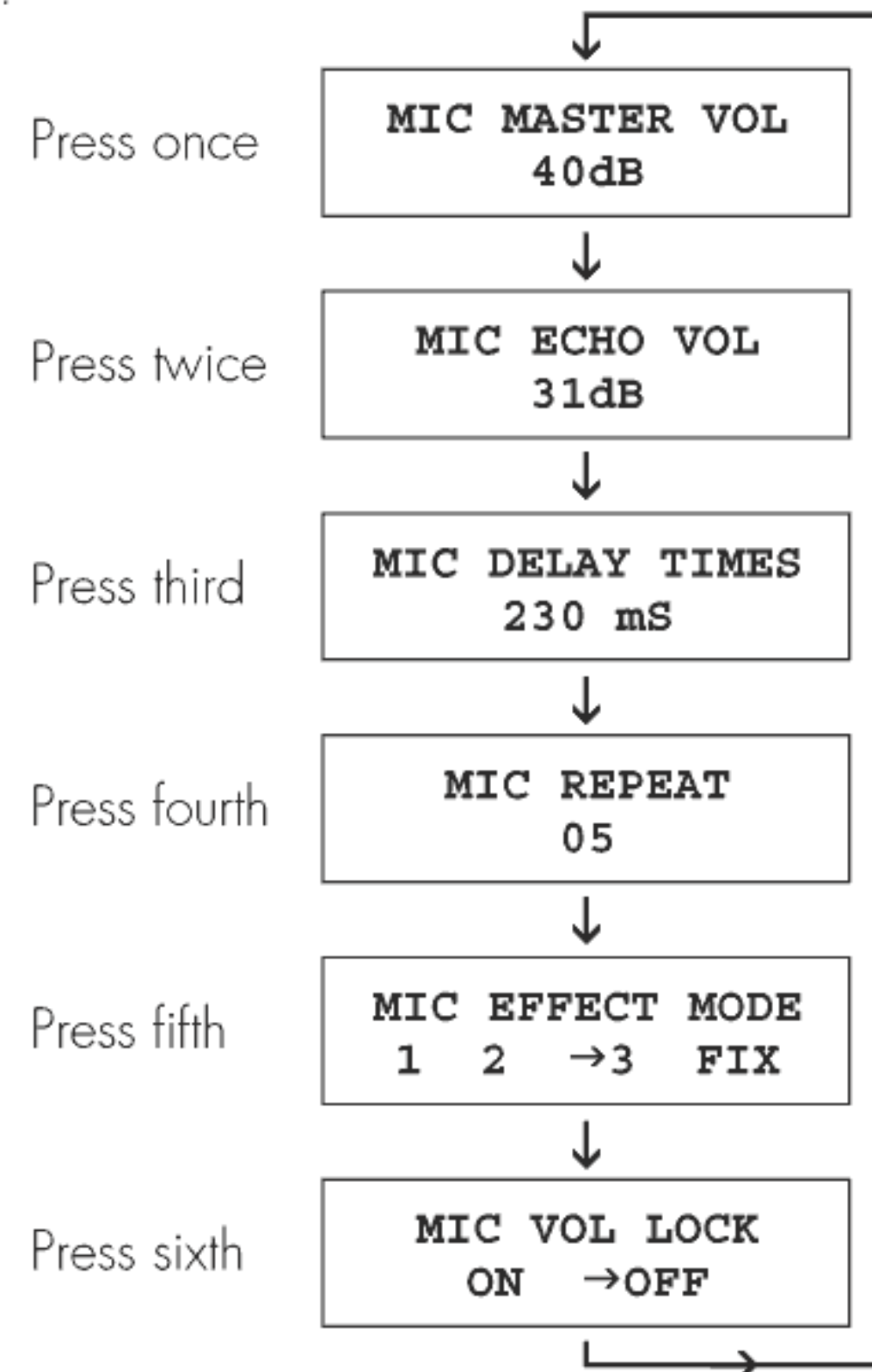

A. Press the **MIC** button for the first time, the Digital Display would appear as follows:

MIC MASTER VOL
40dB

NOTE Press the **UP/DOWN** button to adjust the Mic. volume. Range: 00dB to the maximum 40dB.

ECHO EFFECTS SETTINGS (ECHO, DELAY & REPEAT)

B. Press the **MIC** button for the second time, the Digital Display would appear as follows:

MIC ECHO VOL
31dB

NOTE Press the **UP/DOWN** button to adjust the echo volume. Range: 00dB to 31dB.

C. Press the **MIC** button for the third time, the Digital Display would appear as follows:

MIC DELAY TIMES
230 mS

NOTE Press the **UP/DOWN** button to adjust the delay time. Range: 40 mS to 230 mS

D. Press the **MIC** button for the fourth time, the Digital Display would appear as follows:

MIC REPEAT
16

NOTE Press the **UP/DOWN** button to adjust the Repeat. Range: 00 to 16.

E. Press the **MIC** button for the fifth time, the Digital Display would appear as follows:

MIC EFFECT MODE
1 2 →3 FIX

NOTE Press the **UP/DOWN** button to move the arrow to select the microphone effect modes: 1, 2, 3, or Fix. Mic Effect 1, 2 and 3 are factory preset. Fix is to lock up the user's favorite microphone effect settings. Once fix is selected all microphone effect adjustments (REPEAT, DELAY, and ECHO VOLUME) can't be changed.

F. Press the **MIC** button for the sixth time, the Digital Display would appear as follows:

MIC VOL LOCK
ON →OFF

NOTE Press the **UP/DOWN** button to move the arrow to select **ON** or **OFF** for microphone volume lock. Once you have selected **ON**, the Mic Volume and all MIC mode settings will be locked until you set it off.

❖ Feedback prevention for microphone:

A. Do not use the minimum 40mS for **MIC DELAY TIMES**. We recommend setting **MIC DELAY TIMES** to at least 220 mS.

B. We recommend setting **MIC ECHO VOLUME** level to 12dB, great for singing and karaoke.

C. We recommend setting **MIC REPEAT** to 5 ~16.

D. For wireless microphone, please set the volume of the receiver to a 10 ~12 o'clock position in order to reduce feedback.

MIC TONE EFFECTS (TREBLE, MID & BASS)

7. Adjusting the microphone tone

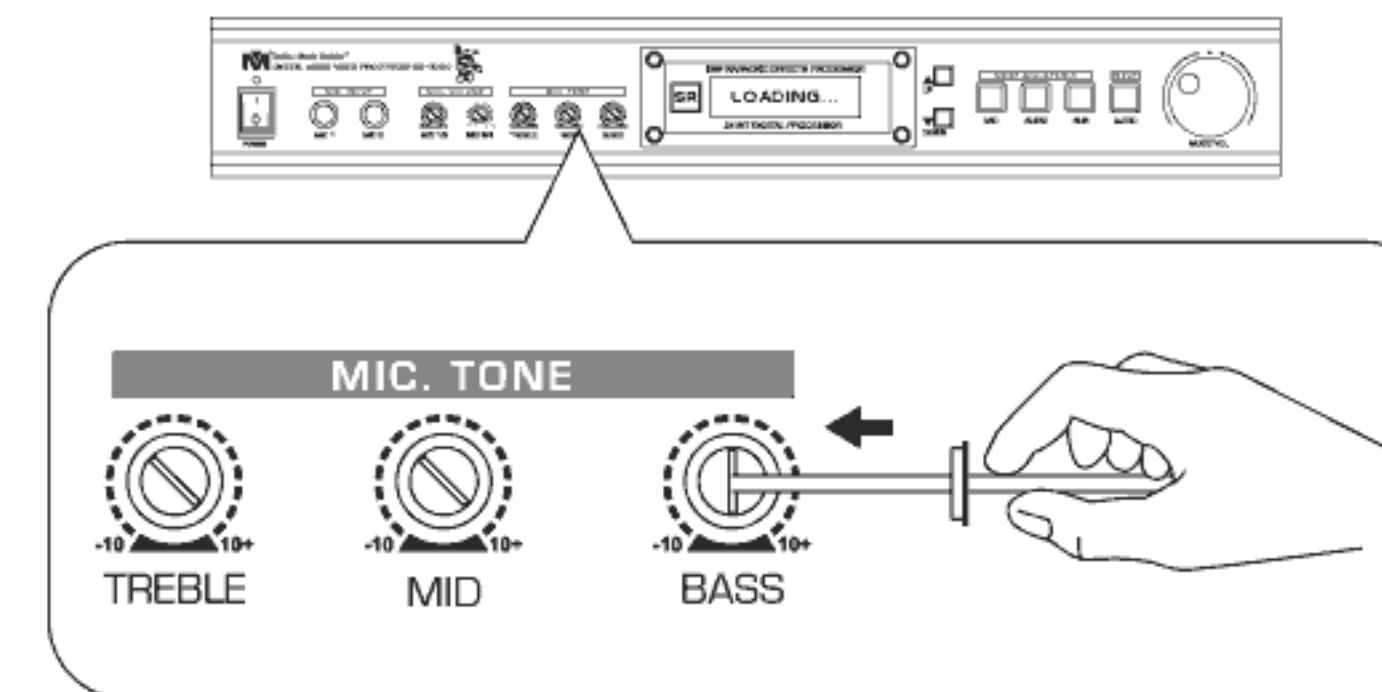

A. There are three knobs under the **MIC TONE**: (1) **BASS** (2) **MID** (3) **TREBLE**

B. **BASS**: Slowly turn the knob clockwise to increase and counter clockwise to decrease the bass output for the microphones.

C. **MID**: Slowly turn the knob clockwise to increase and counter clockwise to decrease the midrange output for the microphones.

D. **TREBLE**: Slowly turn the knob clockwise to increase and counter clockwise to decrease the treble output for the microphones.

8. Adjusting the microphone volume

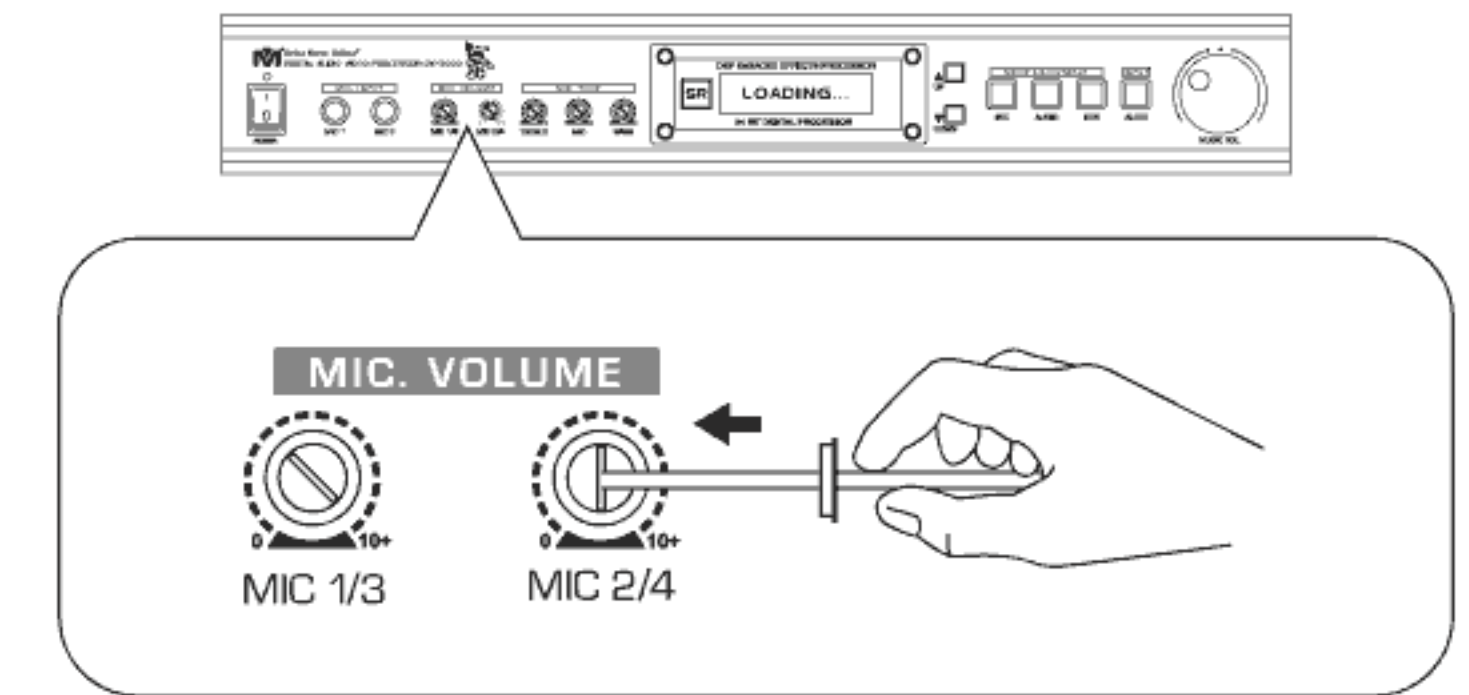

A. There are two knobs under **MIC VOL**: (1) **MIC 1/3** (2) **MIC 2/4**

B. The **MIC 1/3** knob controls the volume for microphone 1 (in front panel) and microphone 3 (in rear panel)

C. The **MIC 2/4** knob controls the volume for microphone 2 (in front panel) and microphone 4 (in rear panel)

9. Microphone Input

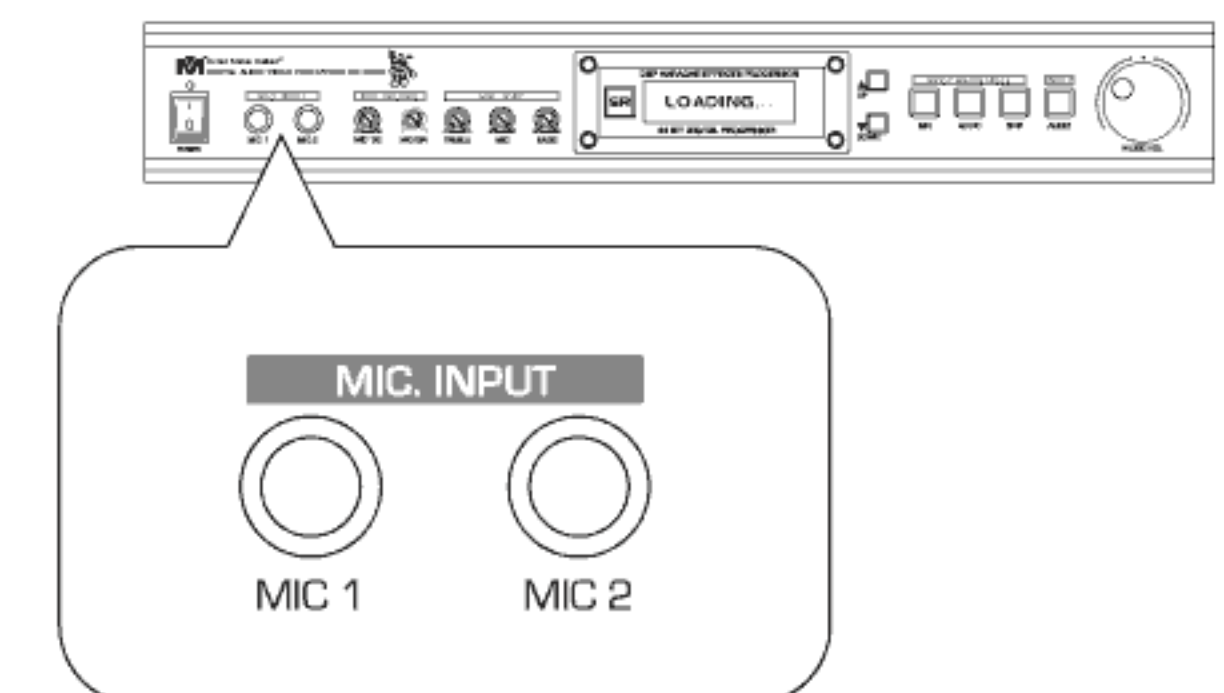

There are two microphone inputs jacks (1/4" unbalanced) in the front panel.

There are two microphone inputs jacks (1/4" unbalanced) in the rear panel.

TROUBLESHOOTING

1. Mode Adjustments Frozen

Symptom: mode adjustments for AUDIO, MIC or SUB frozen.

Probable cause: "MUSIC VOL LOCK" is on, "MIC VOL LOCK" or "WOOFER VOL LOCK" is on.

Remedy: turn off the corresponding volume lock. Please refer to page 27, 28 and 29.

To turn off music lock press audio button 7 times until LCD displays as below, press the up or down button to turn off lock.

MUSIC VOL LOCK
ON → OFF

To turn off subwoofer lock press SUB button 5 times until LCD displays as below, press the up or down button to turn off lock.

WOOFER VOL LOCK
ON → OFF

2. Echo Setting Problems

Symptom: microphone echo, repeat and delay cannot be adjusted.

Probable cause: mic effect mode is set to "FIX" or "MIC VOL LOCK" is on.

Remedy: Select a mic effect mode other than "FIX" or turn "MIC VOL LOCK" off. Please refer to page 29.

MIC VOL LOCK
ON → OFF

Mic effect 1, 2 and 3 are three different manufacturer set effects for the mic digital reverb special effect which can not be changed. Fix is to lock your personal echo settings.

MIC EFFECT MODE
1 2 → 3 FIX

3. No Sound From Subwoofer

Probable cause: SUB is turn off.

Remedy:

- ❖ Please refer to page 26 under topic B to turn on the SUB.
- ❖ Be sure to adjust the SUB volume to a high enough value.
- ❖ Check to make sure subwoofer is turned on
- ❖ Select SUB for all inputs. Please refer to page 26 under topic C.

4. No Sound From Microphone

Remedy:

- ❖ Be sure mic is turned on.
- ❖ Mic cable is connected properly.
- ❖ Check the mic volume

5. Bad Audio or Microphone Sounds

Remedy:

- ❖ Check the source of your audio (CD, DVD) to see if it's scratched.
- ❖ Check your audio cables or microphone cables.
- ❖ Use a better audio cable or 3pin XLR mic cable.

6. Video Problems

Symptom: video is flickering.

Remedy:

- ❖ Check to see if the AV cable is damaged or not.
- ❖ Use a better AV cable.
- ❖ We recommend you to connect videos to the TV or monitor directly for best results.

7. There Is No Picture

Remedy:

- ❖ Check to see if your video sources are selected accordingly.
- ❖ Check to see if you plugged in the video cables.
- ❖ Check your TV or display monitor.

8. Video Signal Out Recommendations

If you have more than 2 RCA output to the display, we recommend you use a signal amplifier. The signal amplifier will stabilize your video quality. If you have a HDTV (Plasma, or LCD) video we recommend you directly connect your source to the video display.

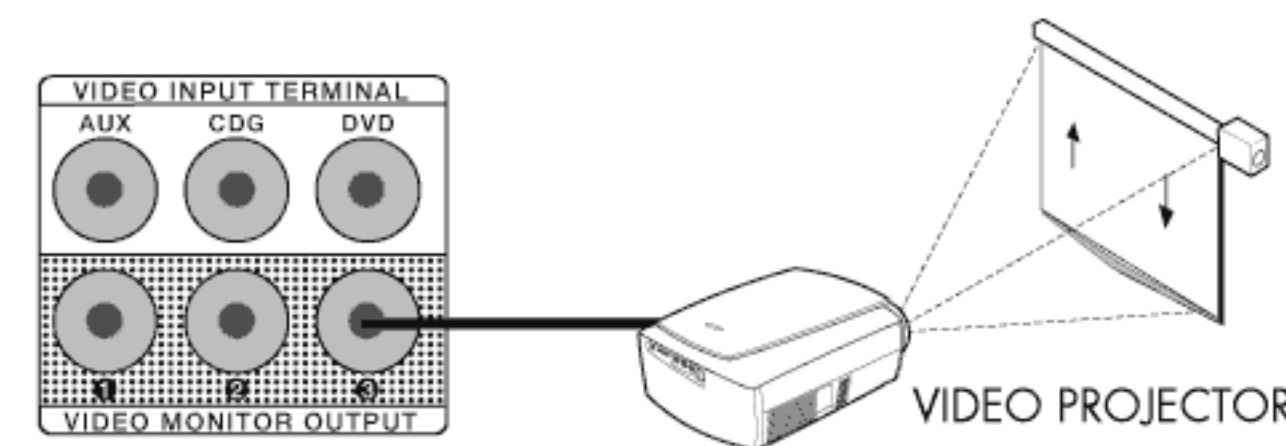

9. Other Problems

If power can not be turned on:

- ❖ Check to see if your unit is plugged in properly.
- ❖ Check your power cable.

10. Microphone No Effect

Symptom: When using microphones (including Front and Rear Input), no change in vocal effect while adjusting "REAR MICROPHONE MODE" (Delay, Repeat and Echo) in the rear panel.

Remedy: In "MIC EFFECT MODE," select "OUTSIDE." Please refer to page 11 under topic 37. REAR OUTPUT TERMINAL.

PHYSICAL

Height	3 inches/ 7.6 cm
Width	17 inches/43.2 cm
Depth	13 inches/ 33 cm
Net Weight	11 lbs/ 5 Kg

Front view

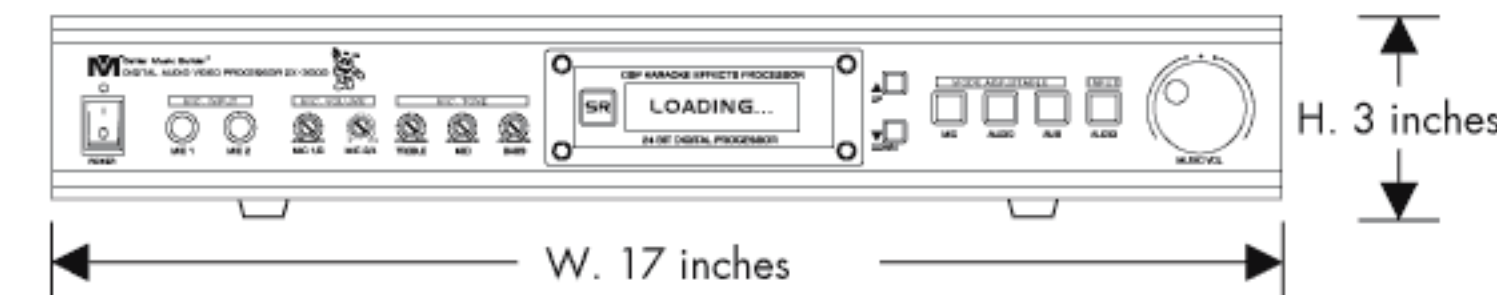

Side view

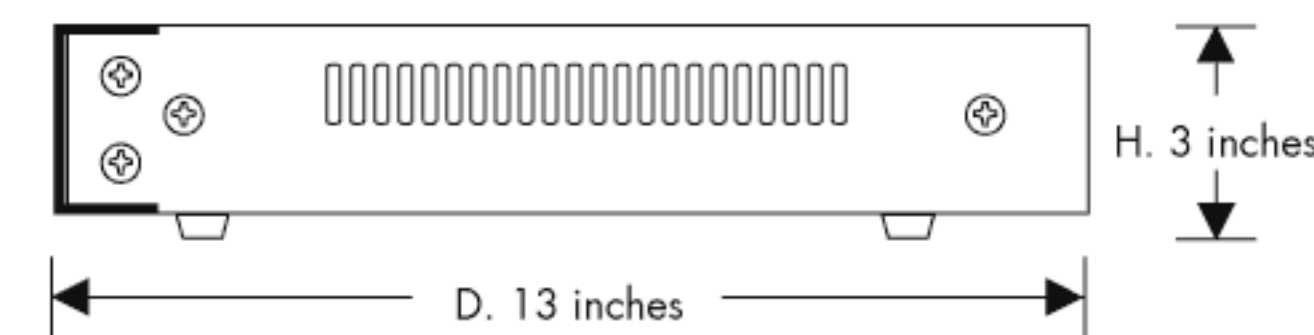

Top view

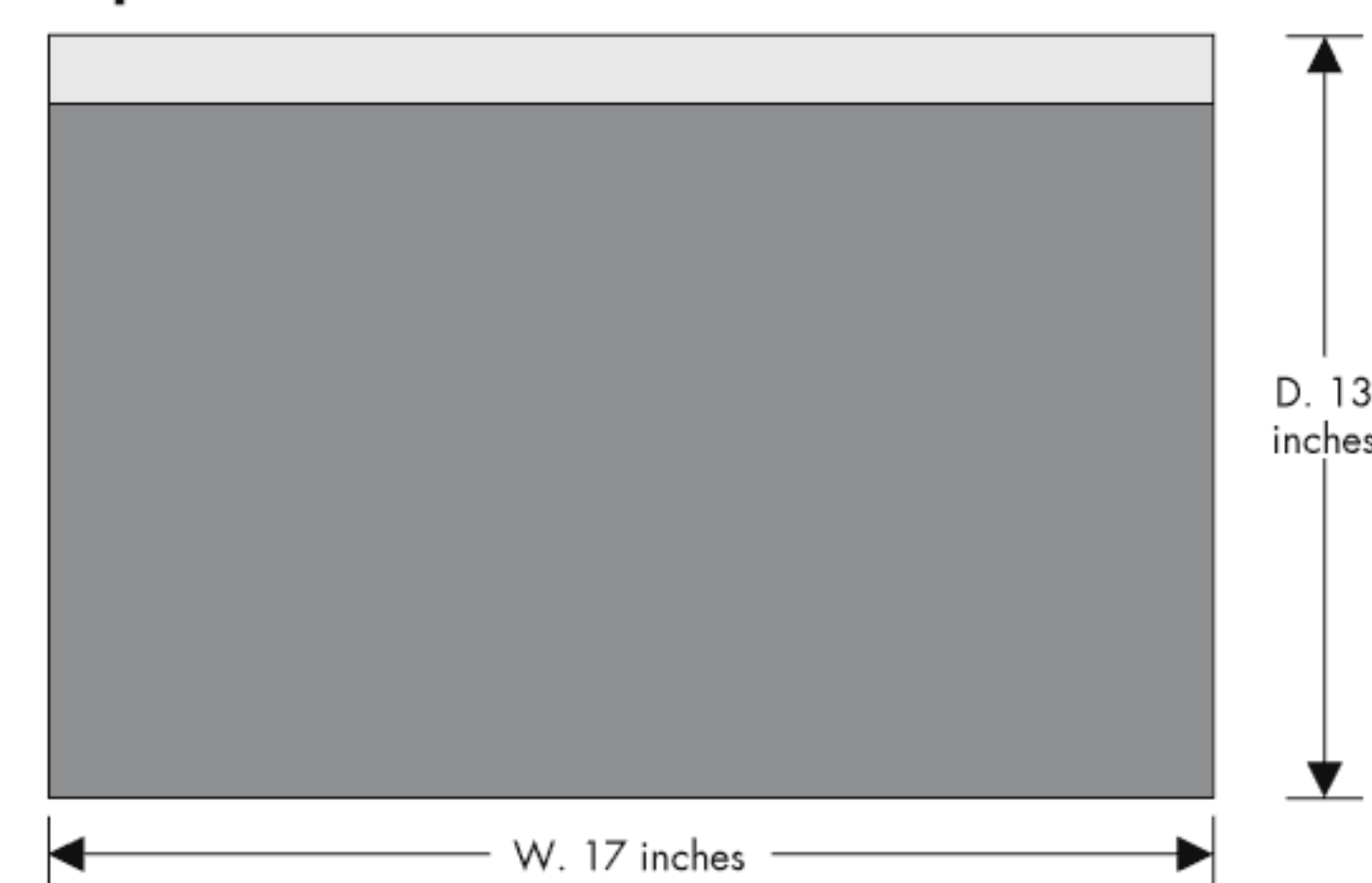

Optional for 19" rack mount kit

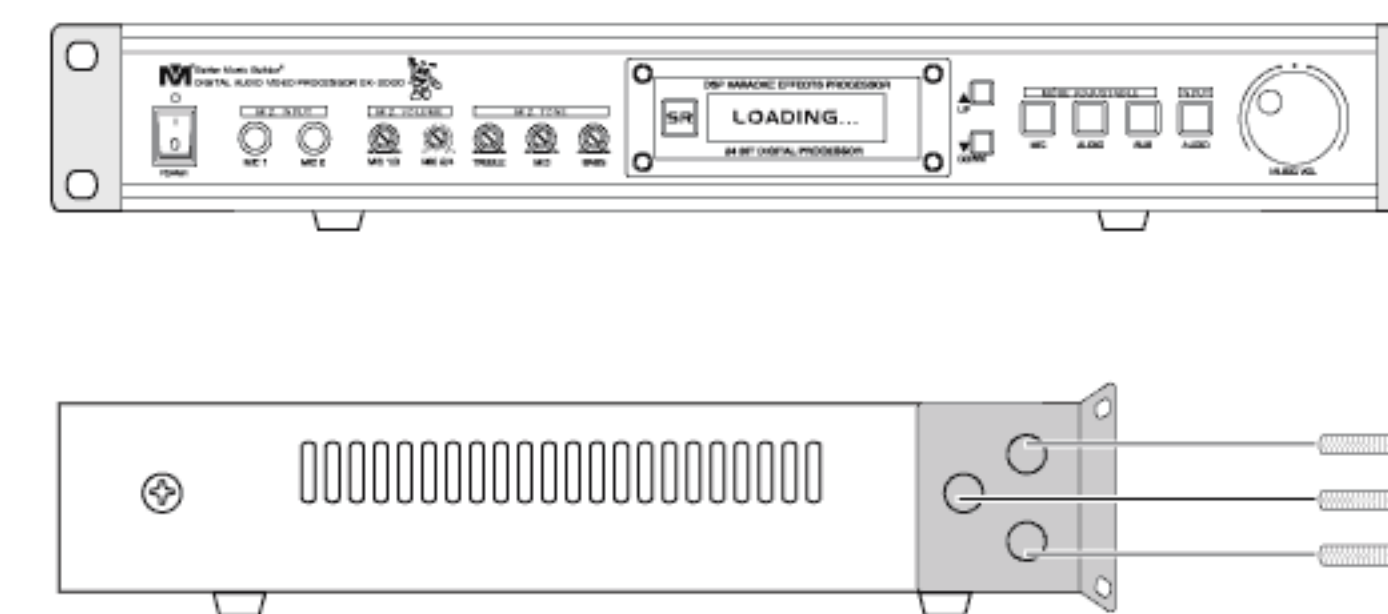

The standard kit is optional. Please make sure that you get the right kit for the size you want. Then, you can put the processor into the rack. The rack is used to protect the processor. If you have such portable equipment, you can have party at home anytime or use it for Karaoke rental business.

The Bracket in figure 1 is used to hold your audio/video equipment firmly in place, but not for transportation. If you need to transport the equipment, we recommend you using the heavy duty clamping rack shelf (optional) as illustrated in figure 2. You should place the heavy duty clamping rack shelf into the portable case. This would protect your equipment. There are different sizes of the heavy duty clamping rack shelves to suit your specific needs. Please note that the bracket, rack shelf and case are not included in the package. They are optional items and sold separately.

Processor Front Bracket for 19" Rack

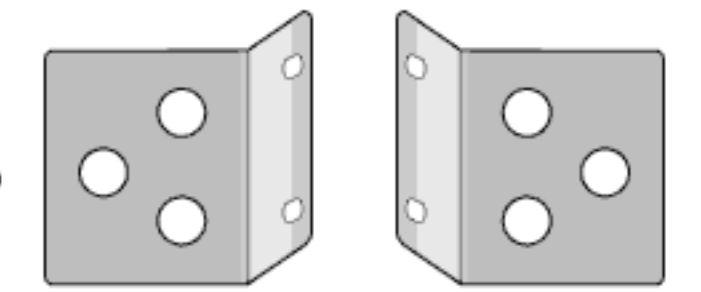

Figure 1

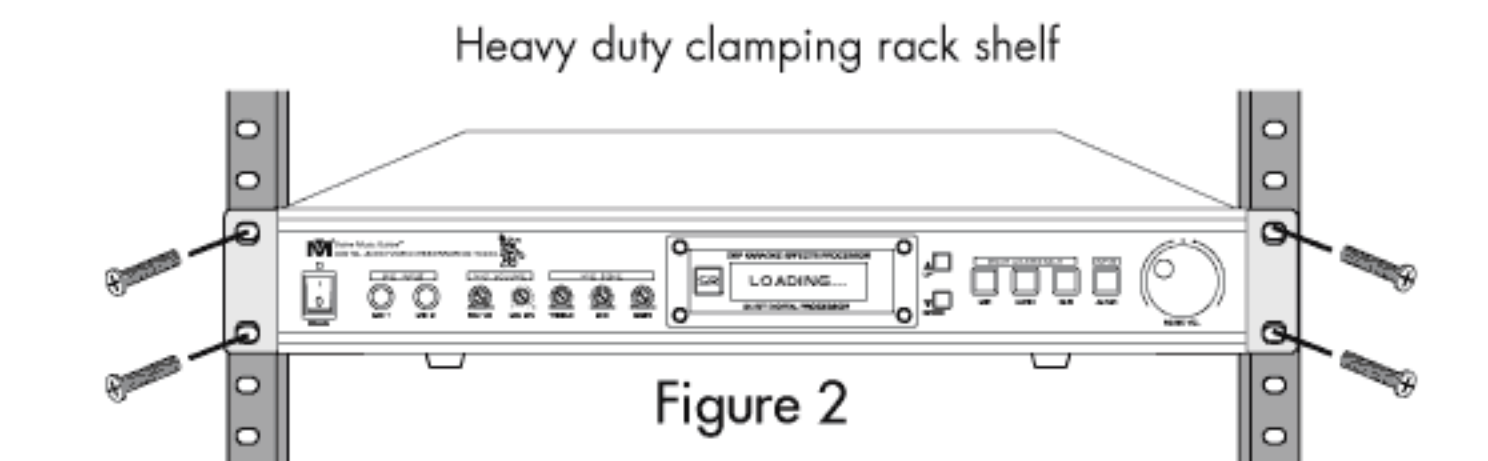
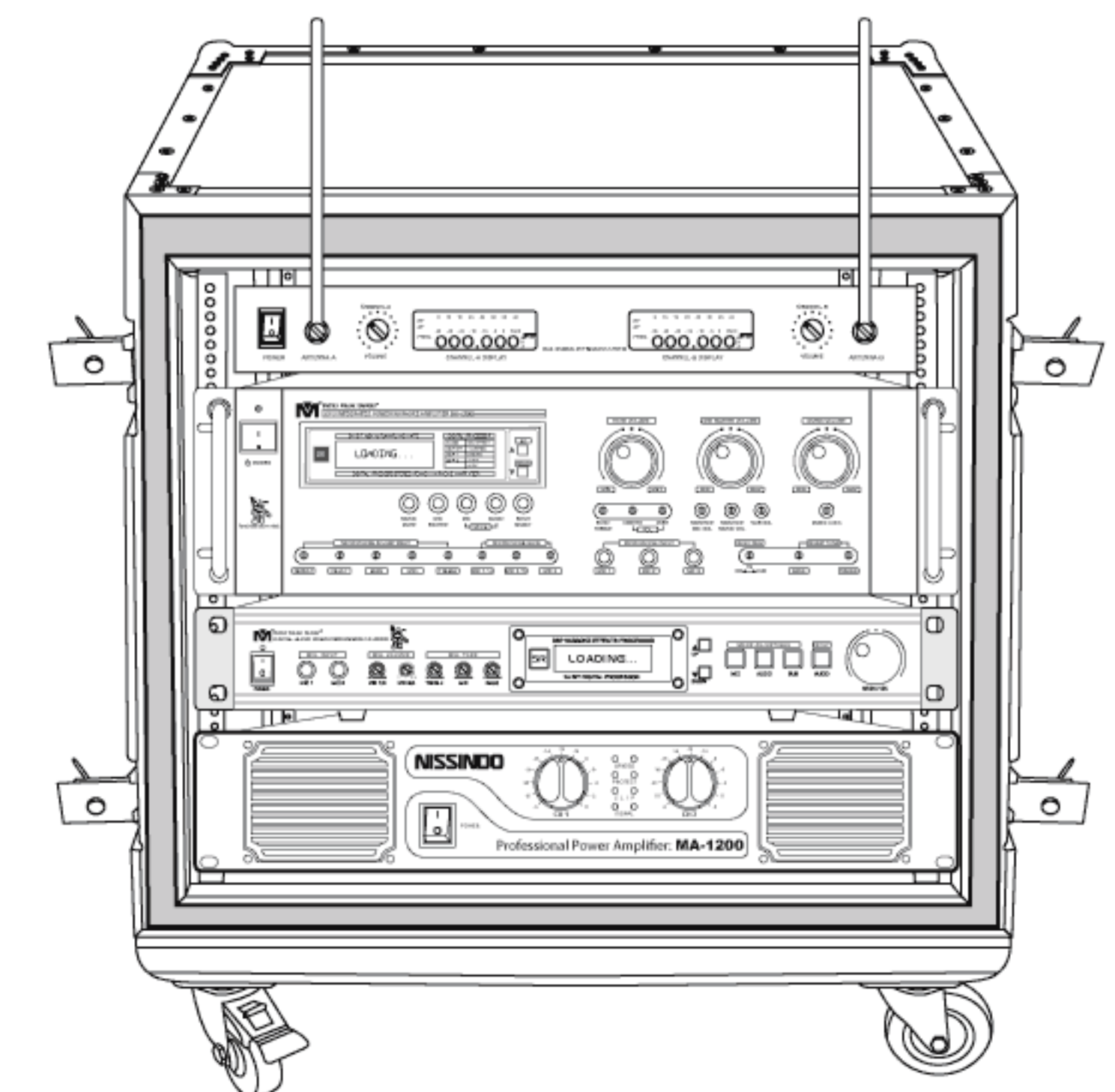

Figure 2



FINAL WORDS TO USER

The engineering team of Better Music Builder has many years of experience in audio equipment design. The team constantly develops new audio technologies, designs innovative audio and Karaoke equipment to suit your specific needs and provides you great ideas for home entertainment. For example, we offer you the great idea to modify your bedroom or basement to become an entertainment place for home theater and Karaoke, so you can have great party with your friends at home.

Our engineering team also designs audio equipment for commercial use by restaurants, coffee shops, churches, and school auditoriums, etc. If the commercial area for audio equipment installation exceeds 2,000 square feet, we highly recommend you to hire audio professionals to handle the installation for you in order to avoid risks in breaking the equipment with improper installation and protecting your own safety.

We also provide you free education and technical information on audio equipment and technologies. For example, we provide free installation diagrams to make it easier for you to connect the system. In addition, to get best connections for the sharpest image and good sound quality, we give you the hot tip for choosing the high quality type of A/V cable for connections. You can download the free information on audio equipment and technologies from our website www.BetterMusicBuilder.com.

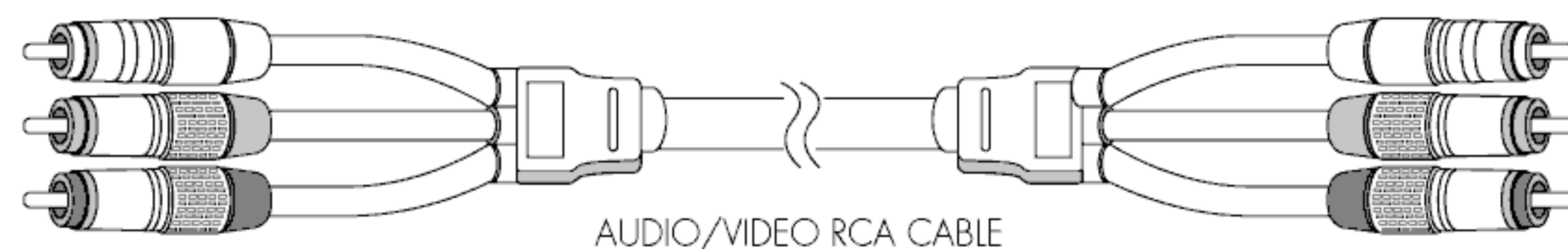
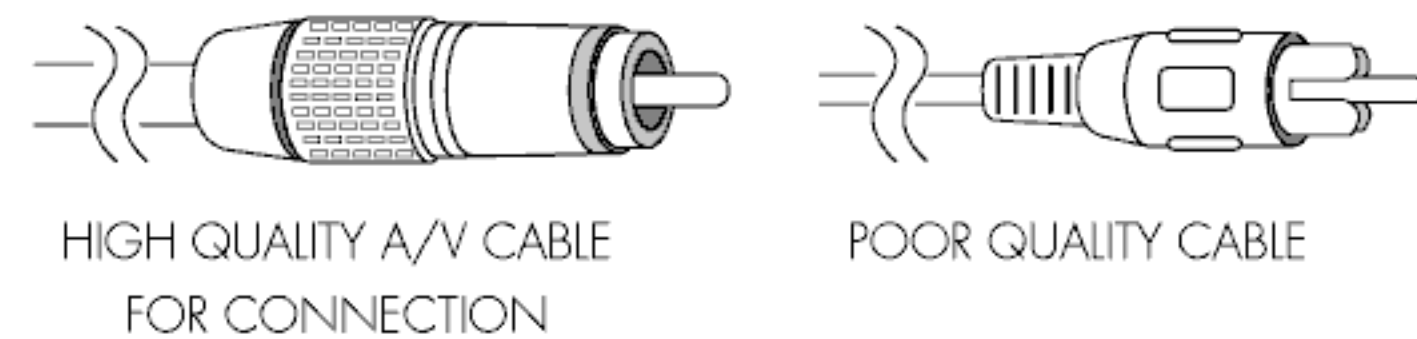

Please do not remove the "Yellow Label" in the rear of your machine, otherwise, the warranty will become void automatically. We design it to protect your own safety. If you need repair and maintenance service, you may contact us directly or hire a professional technician to repair your machine. To learn more about the technical aspects, you can visit our website www.BetterMusicBuilder.com and download the relevant information for review.



NOTE

Before you hook up the system, you must turn off the AC powers on all machines including audio/video equipment and TV. Otherwise, it may damage your equipment, especially on the HDTV in which a spot appeared in the TV screen. After you have hooked up the system, you must double check the audio/video connections to ensure that they are connected correctly.

Sometimes the cable of poor quality would affect the microphone effects, picture quality, or even cause the machine to shut down suddenly.

Again, we must thank you for choosing Better Music Builder product. We hope you can make the best use of the machine and enjoy it for fun. If you have any questions regarding your machine, please feel free to contact us at www.BetterMusicBuilder.com.

WARRANTY

One-year Limited Warranty for Home Use Equipment

Our one-year warranty applies to speakers, amplifiers, mixers and microphones for home use only. It covers both parts and labors. The warranty becomes effective from the date of your purchase for one year.

Our warranty only covers defects due to product defectiveness with free of defects in materials or workmanship. However, our warranty does not cover defects due to normal wears, damage in transit, improper use, abuse or failure to follow the proper instructions for maintenance. This warranty is void in the event of unauthorized repairs, alternations, modifications and removing of the product label.

Please also note that our warranty does not cover any shipping cost for the return of defective products to us for inspection, repair and maintenance. Our warranty for Better Music Builder products can only be executed in North America.

NOTE Our warranty does not cover the battery for wireless remote control.

90-day Limited Warranty for Public and Commercial Use Equipment

Our 90-day warranty applies to speakers, amplifiers, mixers and microphones for both public and commercial use such as restaurant, coffee shop, KTV nightclub, church and school, etc. It covers both parts and labors. The warranty becomes effective from the date of your purchase for 90 days.

Our warranty only covers defects due to product defectiveness with free of defects in materials or workmanship. However, our warranty does not cover defects due to normal wears, damage in transit, improper use, abuse or failure to follow the proper instructions for maintenance. This warranty is void in the event of unauthorized repairs, alternations, modifications and removing of the product label.

Please also note that our warranty does not cover any shipping cost for the return of defective products to us for inspection, repair and maintenance. Our warranty for Better Music Builder products can only be executed in North America.

NOTE Our warranty does not cover the battery for wireless remote control.

To Register Your Warranty

Please fill out the warranty card that came with your unit, download or submit online warranty form. However, we need the invoice for your purchase in order to process this warranty. You may also register your warranty online.

Please visit our website at www.bettermusicbuilder.com.



Passionate about Music
www.BetterMusicBuilder.com