

Better Music Builder® is a leader in the Audio and Karaoke equipment industry. We are committed to offering you high quality audio products. Unlike any others brand, we deliver the best cost and value to you directly. For the latest update information including operation manuals, installation instructions, hook-up diagram and other new technologies updates etc. please visit us at our website www.BetterMusicBuilder.com.

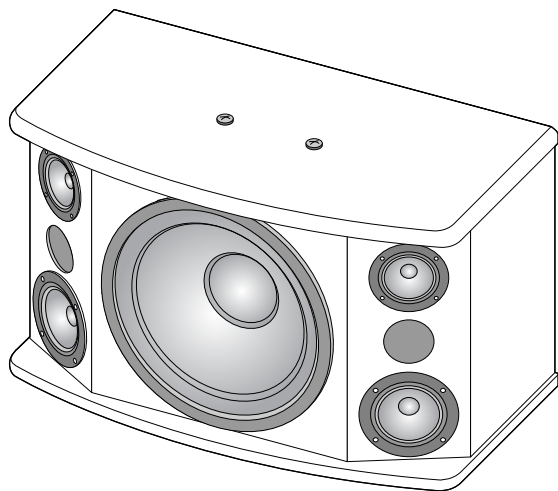

CS-612 G3 (PVC PLYWOOD)

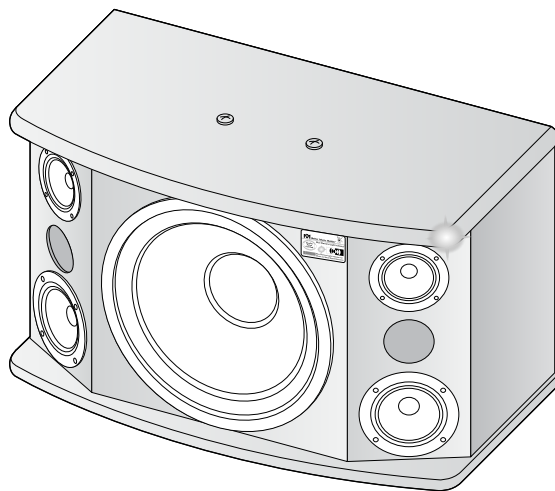

ELEGANT FINISH
CS-812 G3 (BLACK COLOR PIANO WOOD)

OWNER'S MANUAL

CLASSIC SERIES PRO-Line Loudspeaker



110421

3-Way Loudspeaker

PREMIUM GRADE

CS-600 G3 10-inch WOOFER

3-Way Loudspeaker

SUPERIOR GRADE

CS-612 G3 12-inch WOOFER

CS-812 G3 12-inch WOOFER

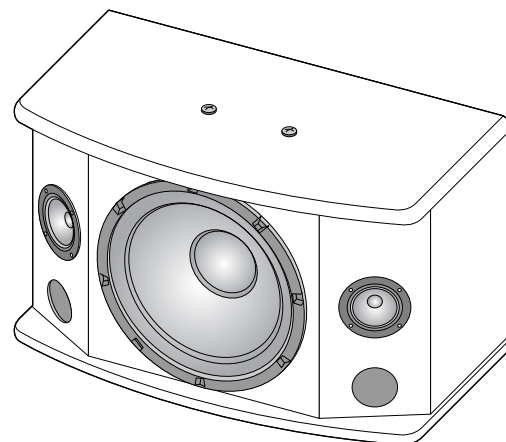















CS-600 G3 (PIANO WOOD)



Thank you for purchasing this unit. To make full and effective use of this unit, please read this Owner's Manual carefully before operating it. Please retain this manual for future reference.

www.BetterMusicBuilder.com

CONTENTS

	INTRODUCTION.....	3
	SYSTEM FEATURES.....	3
	SAFETY INSTRUCTIONS.....	4~5
	SYSTEM APPLICATIONS.....	6
	• Methods of Speaker Connection.....	6
	• Connecting the Speaker.....	6
	• Connecting the Speaker with 3-D Positional Audio (Premium Format).....	7
	• Connecting the Speaker with 5-D Pro Audio (Superior Format).....	8
	CONTROLS AND FUNCTIONS.....	9
	• Front & Rear Panel Features for 3-Way Full Range Speaker Model CS-600 G3.....	9
	• Front & Rear Panel Features for 3-Way Full Range Speaker Model CS-612 G3 / CS-812 G3.....	9
	SYSTEM SETUP GUIDELINES.....	10
	• Installation Setup.....	10
	1. Mounting the Speaker to the Ceiling.....	10
	2. Mounting the Speaker to the Wall.....	11
	3. Placing the Speaker on the Floor to Monitor Singing.....	12
	4. Placing the Speaker on the Portable Stand.....	12
	• Recommended Tools.....	13
	• Logo Rotation.....	13
	PHYSICAL DIMENSIONS.....	14~15
	SPECIFICATIONS.....	15
	TROUBLESHOOTING.....	16~17
	FINAL WORDS TO USER.....	17
	WARRANTY.....	18
	AGENCY REGULATORY NOTICES.....	19
	NEW PRODUCTS (MUSIC SOURCE).....	20~21
	CONTACT INFORMATION.....	22



INTRODUCTION

Better Music Builder is excited to introduce the next generation of the Classic Series speaker, the CS-812 G3.

The high performance speaker uses dynamic audio computer simulation design technology. It enables the speaker to produce high quality sound, precise clarity and strong reliability. These speakers are made using high temperature treated magnesium diaphragm, voice coil with copper cladding aluminum wire, and compression cavity designed with linear phase technology. Its featured magnetic circuit tweeter generates high magnetic energy, low distortion, excellent ventilation function, and high strength plywood that can absorb unwanted noise for high performance.

Unchanged since it was first introduced is its elegant design. Its cabinet is designed with glossy piano wood to provide a stronger foundation for both structure and sound. The material is utilized based on the principle that softer wood provides smoother and clearer sound, just like a grand piano.

Utilizing the added mid frequency tweeter, the 3-way speaker delivers a new dimension to its dynamic sound. The midrange driver is a very significant part of the audio sound spectrum as it creates sounds which are most familiar to the human ear such as musical instruments and human voice.

A new feature on the CS-812 G3 is its iconic blue LED light. The blue diamond light acts as an indicator for music signal detection. This allows the users for accurate detection of their speaker sounds enabling them to control the music and vocal more effectively.

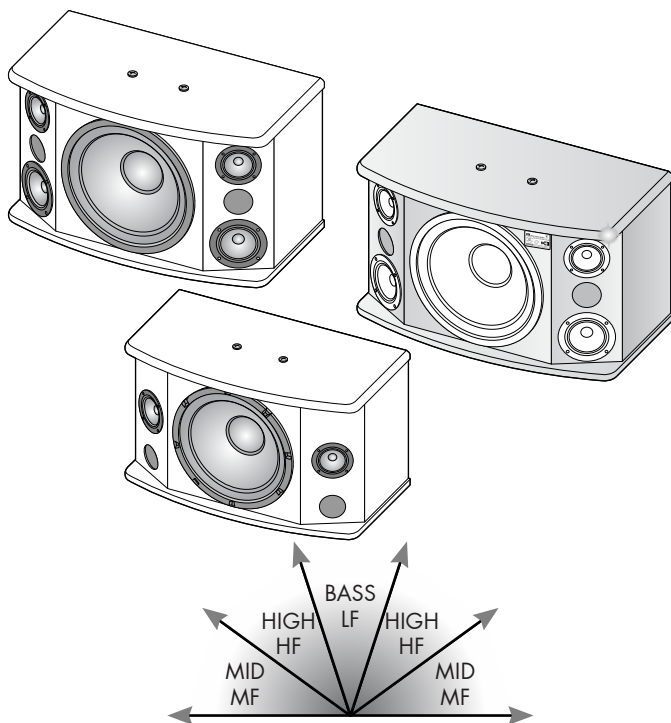

SYSTEM FEATURES

CS-600 G3 (Premium Grade)

- 3-Way Full Range Piano Wood Speaker
- 3"x1 tweeters [paper cone high frequency drivers]
- 3"x1 tweeters [paper cone middle frequency drivers]
- 10"x1 woofer [low frequency woofer]
- High output SPL and sensitivity
- Copper wired voice coil
- Speaker input terminal (banana plug or insert type)
- Frequency response 40Hz~18kHz
- Sensitivity 91dB
- Front grill adjustable 180 degrees
- Cabinet design for FOH use
- Flexible and easy-to install configurations (wall, ceiling, under balcony)

CS-612 G3 (Superior Grade)

- 3-Way Full Range PVC/Plywood Speaker
- 3"x2 tweeters [paper cone high frequency drivers]
- 4"x2 tweeters [paper cone middle frequency drivers]
- 12"x1 woofer [low frequency woofer]
- High output SPL and sensitivity
- Copper wired voice coil
- Speaker input terminal (banana plug or insert type)
- Frequency response 25Hz~18kHz
- Sensitivity 93dB
- Front grill adjustable 180 degrees
- Cabinet design for FOH use
- Flexible and easy-to install configurations (wall, ceiling, under balcony)

CS-812 G3 (Superior Grade)

- Blue diamond light indicator for music signal detection.
- 3-Way Full Range Piano Wood Speaker
- 3"x2 tweeters [paper cone high frequency drivers]
- 4"x2 tweeters [paper cone middle frequency drivers]
- 12"x1 woofer [low frequency woofer]
- High output SPL and sensitivity
- Copper wired voice coil
- Speaker input terminal (banana plug or insert type)
- Frequency response 25Hz~18kHz
- Sensitivity 93dB
- Front grill adjustable 180 degrees
- Cabinet design for FOH use
- Flexible and easy-to install configurations (wall, ceiling, under balcony)

CLASSIC SERIES
PRO-Line Loudspeaker





SAFETY INSTRUCTIONS

We will not notify you any errors or changes in this manual in advance. If there are any errors and changes in this manual, we will make the corrections in a timely manner. The corrections and changes will be on our website. Therefore, please visit our website at BetterMusicBuilder.com frequently to find out the most updated information, corrections on errors and changes in this manual. You may also contact us at toll free at 1-800-318-2218.

 CAUTION RISK OF ELECTRIC SHOCK DO NOT OPEN 
CAUTION: TO REDUCE THE RISK OF ELECTRIC SHOCK DO NOT REMOVE COVER (OR BACK) NO USER-SERVICEABLE PARTS INSIDE REFER SERVICING TO QUALIFIED PERSONNEL

CAUTIONS FOR INSTALLATION

POWER SUPPLY / POWER CORD

- Only use the voltage specified as correct for the device. The required voltage is printed on the name plate of the device.
- Use only the included power cord.
- Do not place the power cord near heat sources such as heaters or radiators, and do not excessively bend or otherwise damage the cord, place heavy objects on it, or place it in a position where anyone could walk on, trip over, or roll anything over it.
- Remove the electric plug from the outlet when the device is not to be used for extended periods of time, or during electrical storms.
- When removing the electric plug from the device or an outlet, always hold the plug itself and not the cord. Pulling by the cord can damage it.

DO NOT OPEN

- Do not open the device or attempt to disassemble the internal parts or modify them in any way. The device contains no user-serviceable parts. If it should appear to be malfunctioning, discontinue use immediately and have it inspected by qualified Better Music Builder service personnel.

WATER WARNING

- Do not expose the device to rain, use it near water or in damp or wet conditions, or place containers on it containing liquids which might spill into an openings.
- Never insert or remove an electric plug with wet hands.

ABNORMALITY

- If the power cord or plug becomes frayed or damaged, or if there is a sudden loss of sound during use of the device, or if any unusual smells or smoke should appear to be caused by it, immediately turn off the power switch, disconnect the electric plug from the outlet, and have the device inspected by qualified Better Music Builder service personnel.
- If this device should be dropped or damaged, immediately turn off the power switch, disconnect the electric plug from the outlet, and have the device inspected by qualified Better Music Builder service personnel.

LOCATION

- Always consult qualified Better Music Builder service personnel if the device installation requires construction work, and make sure to observe the following precautions.
- Choose mounting hardware and an installation location that can support the weight of the device.
- Avoid locations that are exposed to constant vibration.

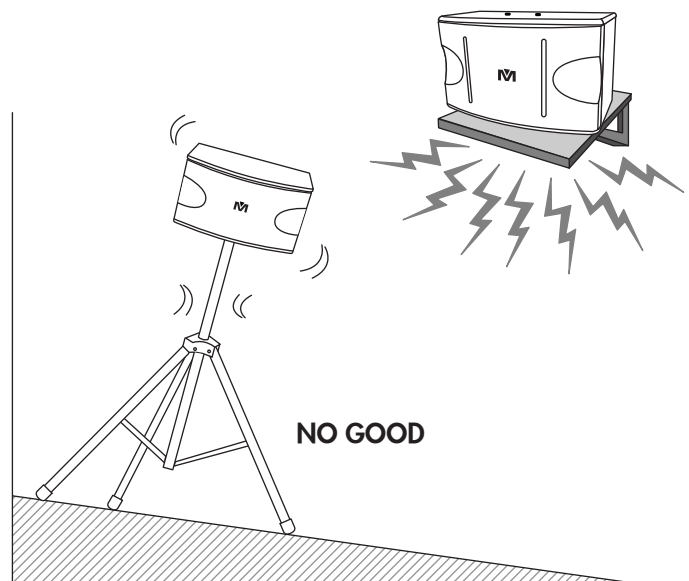

- Inspect the device periodically.
- When transporting or moving the device, always use two or more person. Attempting to lift the device by yourself may damage your back, result in other injury, or cause damage to the device itself.
- Before moving the device, remove all connected cables.
- Do not use the device in a confined, poorly-ventilated location. If this device is to be used in a small space other than an EIA-standard rack, make sure that there is adequate space between the device and surrounding walls or other devices: at least 30cm at the sides, 30cm behind and 30cm above. Inadequate ventilation can result in overheating, possibly causing damage to the device(s), or even fire.

- Do not use the speaker's handles for suspended installation. Doing so can result in damage or injury.
- Do not expose the device to excessive dust or vibrations, or extreme cold or heat (such as in direct sunlight, near a heater, or in a car during the day) to prevent the possibility of panel disfiguration or damage to the internal components.
- Do not place the device in an unstable position where it might accidentally fall over.

CONNECTIONS

- Before connecting the device to other devices, turn off the power for all devices. Before turning the power on or off for all devices, set all volume levels to minimum.

CAUTION

- When turning on the AC power in your audio system, always turn on the device LAST, to avoid speaker damage. When turning the power off, the device should be turned off FIRST for the same reason.
- Do not insert your fingers or hands in any gaps or openings on the device (ports, etc.).
- Avoid inserting or dropping foreign objects (paper, plastic, metal, etc.) into any gaps or openings on the device (ports, etc.). If this happens, turn off the power immediately and unplug the power cord from the AC outlet. Then have the device inspected by qualified Better Music Builder service personnel.
- Do not use the device for a long period of time at a high or uncomfortable volume level, since this can cause permanent hearing loss. If you experience any hearing loss or ringing in the ears, consult a physician.
- Do not operate the device if the sound is distorting. Prolonged use in this condition could cause overheating and result in fire.
- Do not rest your weight on the device or place heavy objects on it, and avoid using excessive force on the buttons, switches or connectors.

GETTING STARTED

WIRING

IMPORTANT: Make sure all equipments are turned off before making any connections.

For speaker connections, use a high-quality speaker wire with polarity coding. The side of the wire with a ridge or other coding is usually considered positive polarity.

NOTE If desired, consult Better Music Builder technical support for speaker wire and connection options.

The speakers have coded terminals that accept a variety of wire connectors.

To ensure proper polarity, connect each + terminal on the back of the amplifier or receiver to the respective + (red) terminal on each speaker. Connect the - (black) terminals in a similar way. See the owner's guides that were included with your amplifier, receiver and television to confirm connection procedures.

IMPORTANT: Do not reverse polarities (i.e., + to - or - to +) when making connections. Doing so will cause poor imaging and diminished bass response.

ADJUSTING

Check the speakers for playback, first by setting the system volume control to a minimum level, and then by applying power to your audio system. Play a favorite music or video segment and increase the system volume control to a comfortable level.

NOTE You should hear balanced audio reproduction across the entire frequency spectrum. If not, check all wiring connections or consult the authorized dealer from whom you purchased the system for more help.

The amount of bass you hear and the stereo-image quality will be affected by a number of different factors, including the room's size and shape, the construction materials used to build the room, the listener's position relative to the speakers, and the position of the speakers in the room.

Listen to a variety of music selections and note the bass level. If there is too much bass, move the speakers away from nearby walls. Conversely, if you place the speakers closer to the walls, there will be more bass output.

CARING

Each enclosure has a finish that does not require any routine maintenance. When needed, use a soft cloth to remove any fingerprints or dust from the enclosure or grille.



SYSTEM APPLICATIONS

CONNECTING THE SPEAKERS

HOW TO CONNECT THE SPEAKER TO AMPLIFIER

We at Better Music Builder always provide you the technical support and relevant information to help you make the best use of your audio equipment. To avoid damages in connection mistakes please refer to the following three diagrams showing our recommended connections for the different speaker impedance.

NOTE Please turn off amplifier power prior to connection.

PARALLEL WIRING

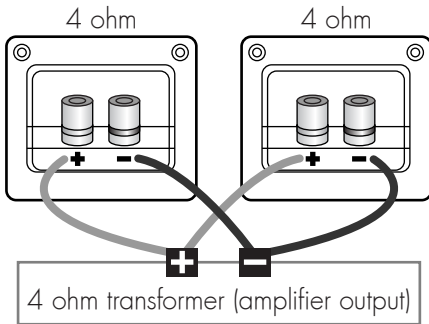

SERIES WIRING

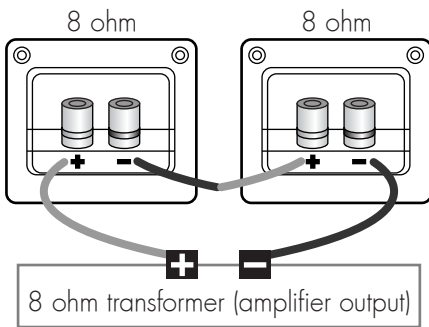

SERIES / PARALLEL WIRING

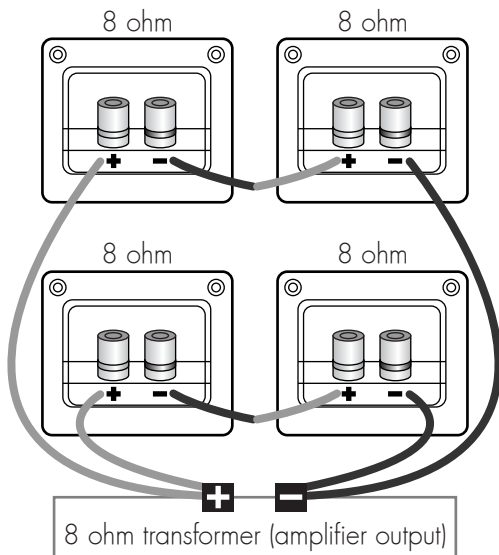

METHODS OF SPEAKER CONNECTION

1. Insert Type (Standard Connection)

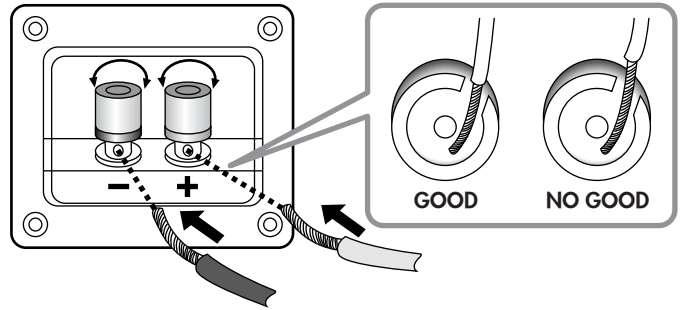

2. Single Banana Plug Type (Better Connection)

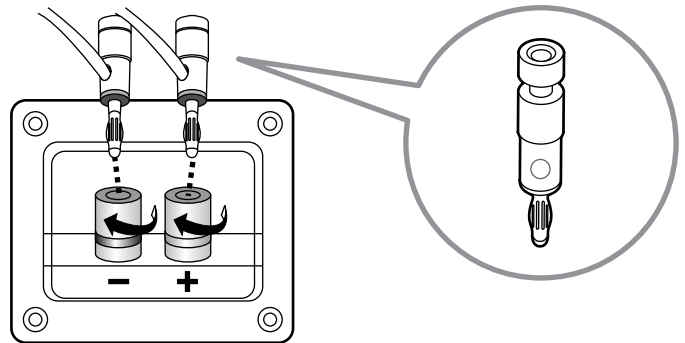

3. Double Banana Plug Type (Best Connection)

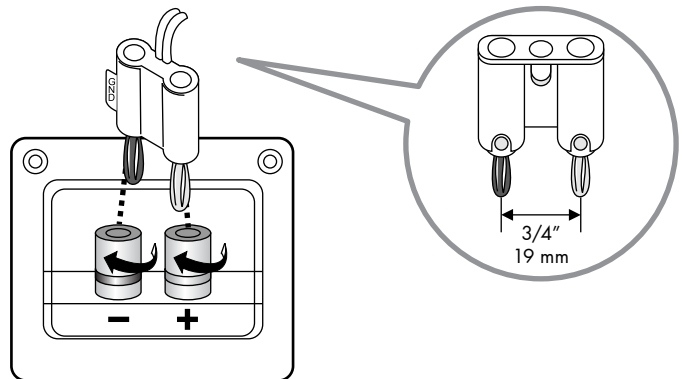

Either banana plug or insert type can be used to connect the unit to speakers. Be sure to connect red (+) to red (+) and black (-) to black (-). Otherwise, the sound output would be 180° out of phase and distorted.

Follow these steps if you are inserting the wire directly into the speaker terminal.

1. Strip off the vinyl covering and twist the tip of the wire core.
2. Loosen the knob and insert the wire core into the terminal hole.
3. Tighten the knob to fix the wire core in place.

Do not allow the wire core to protrude or touch other terminals or wires. If the cores of differing wires touch, damage may result to your components.

CONNECTING THE SPEAKER WITH 3-D POSITIONAL AUDIO (PREMIUM FORMAT)

Please refer to the diagram on the right for connecting the speakers to the 3-D Positional Audio system designed by the Better Music Builder engineering team.

With 3-D Positional Audio technology, user can actually experience the following effects:

- Live music and sound effects.
- Clear sounds at low volume.
- Superior dialog clarity.
- Reveals natural depth and details.
- Music is natural and brilliant with strong bass.

Model: DX-222 G2 3-D Positional Audio

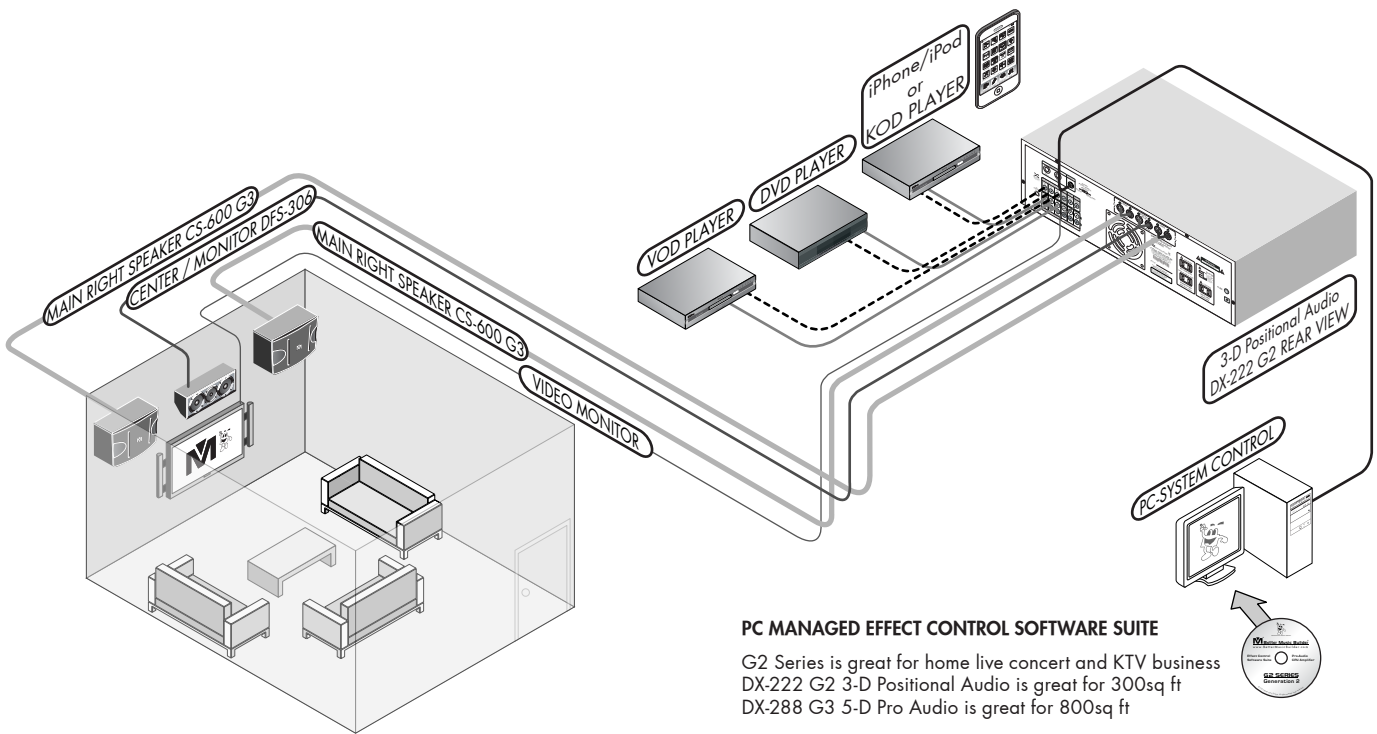
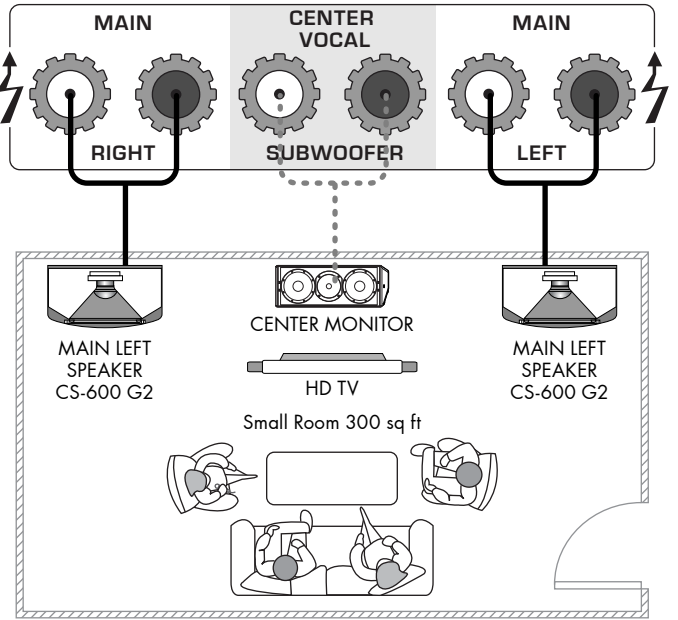

PC MANAGED EFFECT CONTROL SOFTWARE SUITE
 G2 Series is great for home live concert and KTV business
 DX-222 G2 3-D Positional Audio is great for 300sq ft
 DX-288 G3 5-D Pro Audio is great for 800sq ft

CONNECTING THE SPEAKER WITH 5-D PRO AUDIO (SUPERIOR FORMAT)

Please refer to the diagram on the right for connecting the speakers to the 5-D Pro Audio system designed by the Better Music Builder engineering team.

Model: DX-288 G3 5-D PRO Audio

The concept of 5-D Pro Audio technology is the same as that of the 3-D Positional Audio technology. The 5-D Pro Audio technology factors in the echo and reverb generated by the size and shape of the room as well as the materials used in the construction of the room into the Digital Signal Processing equation. The control feedback can easily be done from the front panel as with the adjustment of vocal and music effects between the center and main speakers.

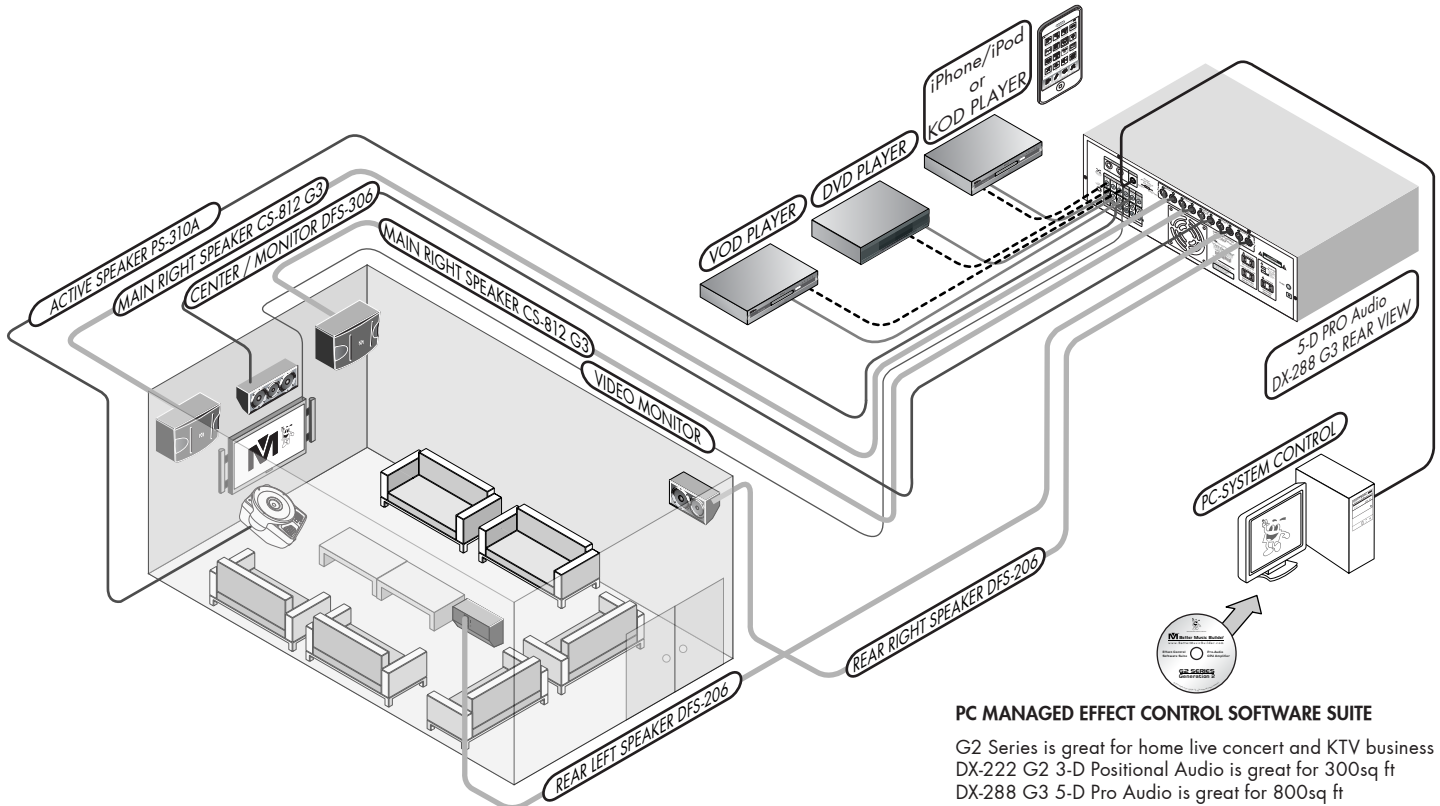
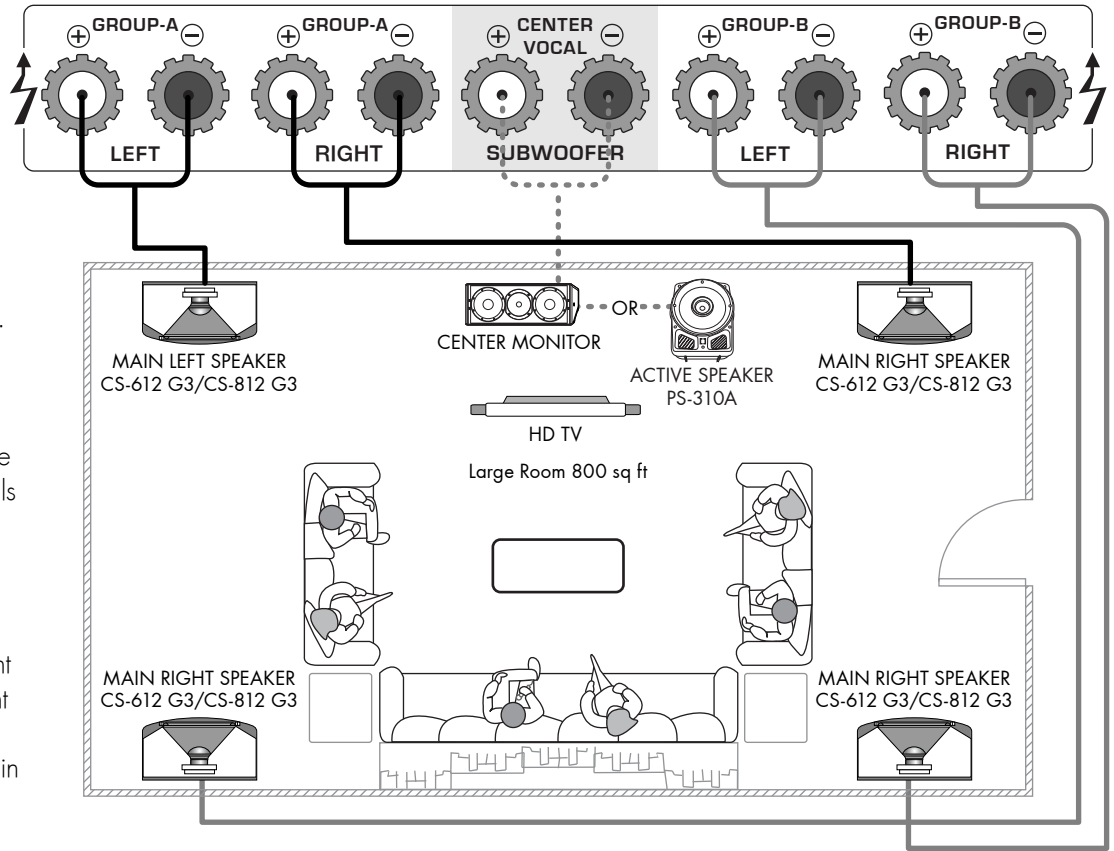

PC MANAGED EFFECT CONTROL SOFTWARE SUITE
 G2 Series is great for home live concert and KTV business
 DX-222 G2 3-D Positional Audio is great for 300sq ft
 DX-288 G3 5-D Pro Audio is great for 800sq ft



CONTROLS AND FUNCTIONS

FRONT & REAR PANEL: features are available for model CS-600 G3

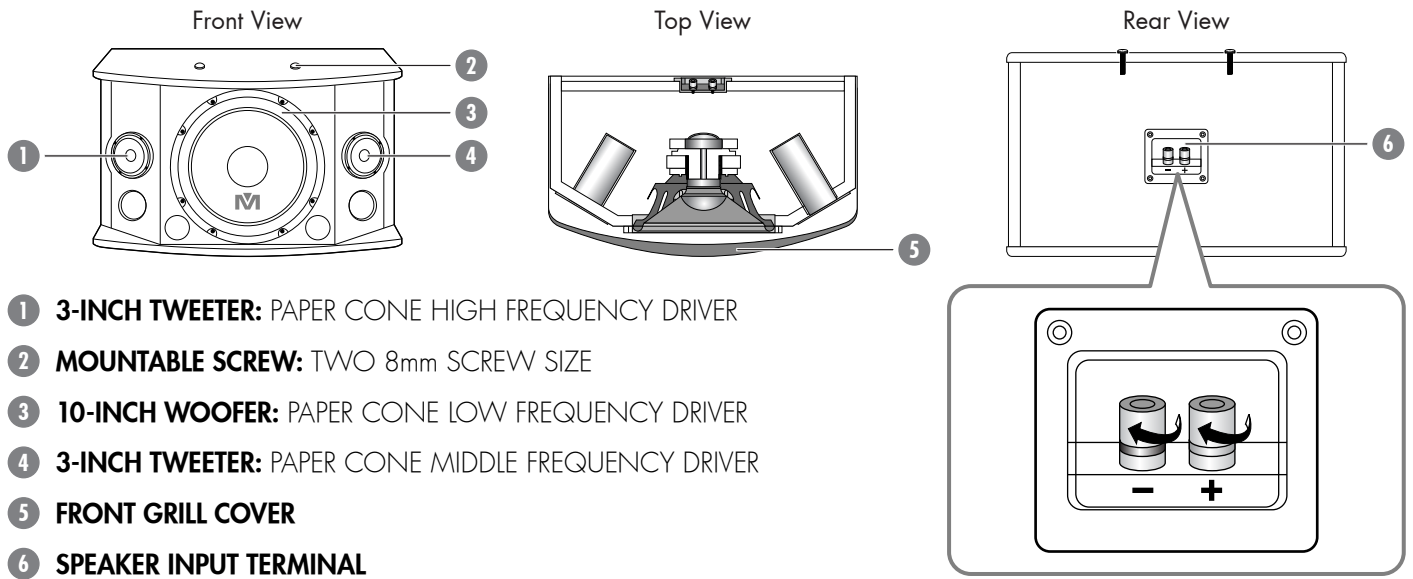

- 1 **3-INCH TWEETER:** PAPER CONE HIGH FREQUENCY DRIVER
- 2 **MOUNTABLE SCREW:** TWO 8mm SCREW SIZE
- 3 **10-INCH WOOFER:** PAPER CONE LOW FREQUENCY DRIVER
- 4 **3-INCH TWEETER:** PAPER CONE MIDDLE FREQUENCY DRIVER
- 5 **FRONT GRILL COVER**
- 6 **SPEAKER INPUT TERMINAL**

FRONT & REAR PANEL: features are available for model CS-612 G3/CS-812 G3

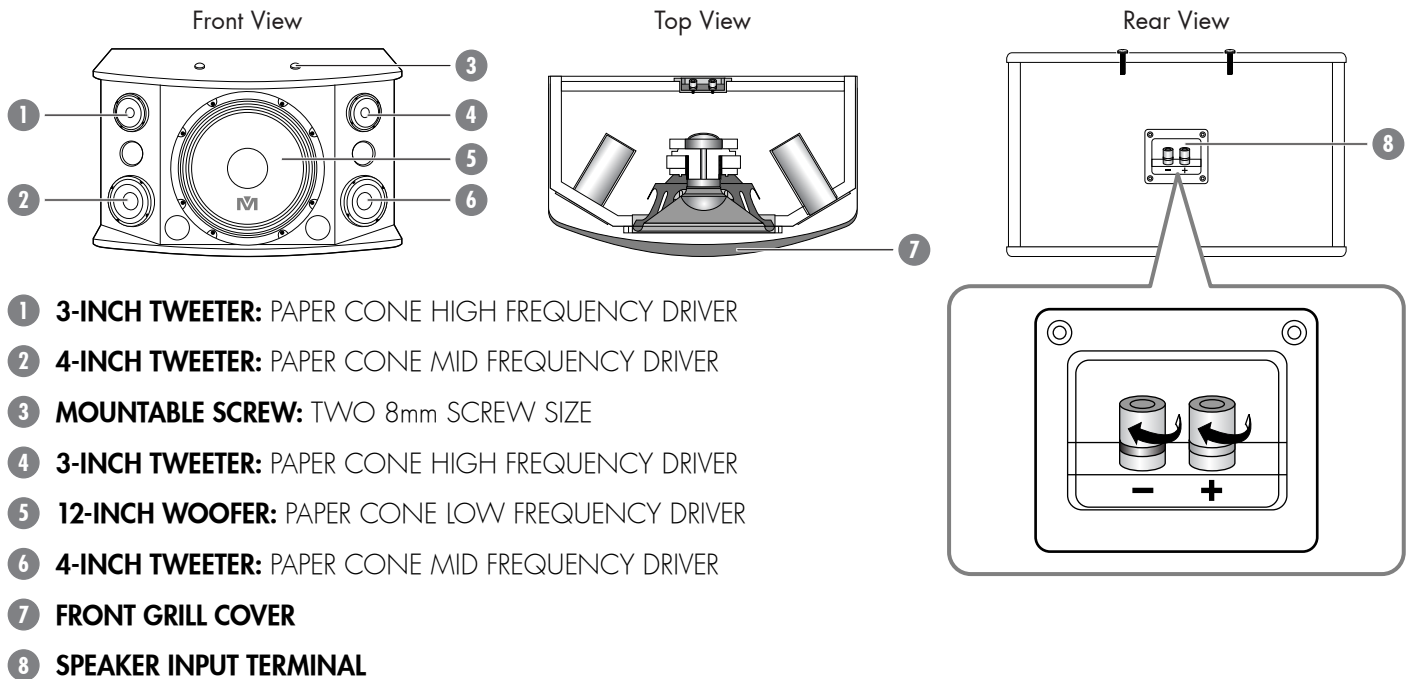

- 1 **3-INCH TWEETER:** PAPER CONE HIGH FREQUENCY DRIVER
- 2 **4-INCH TWEETER:** PAPER CONE MID FREQUENCY DRIVER
- 3 **MOUNTABLE SCREW:** TWO 8mm SCREW SIZE
- 4 **3-INCH TWEETER:** PAPER CONE HIGH FREQUENCY DRIVER
- 5 **12-INCH WOOFER:** PAPER CONE LOW FREQUENCY DRIVER
- 6 **4-INCH TWEETER:** PAPER CONE MID FREQUENCY DRIVER
- 7 **FRONT GRILL COVER**
- 8 **SPEAKER INPUT TERMINAL**

- 9 **BLUE DIAMOND LIGHT INDICATOR** (Available on CS-812 G3 only):
BLUE DIAMOND LIGHT INDICATOR FOR MUSIC AND VOCAL SIGNAL DETECTION

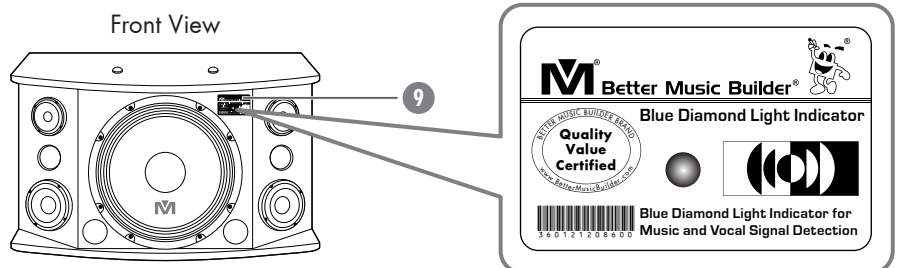

CS-600 G3

CS-612 G3/CS-812 G3



SYSTEM SETUP GUIDELINES

INSTALLATION SETUP

1. MOUNTING THE SPEAKER TO THE CEILING

STEP 1: Place the wall mount panel on the top of the speaker cabinet and use two screws to fasten it.

STEP 2: Then, use four screws to hold the speaker firmly into the wall.

NOTE The structure of the ceiling must be strong enough to hold at least 50 pounds.

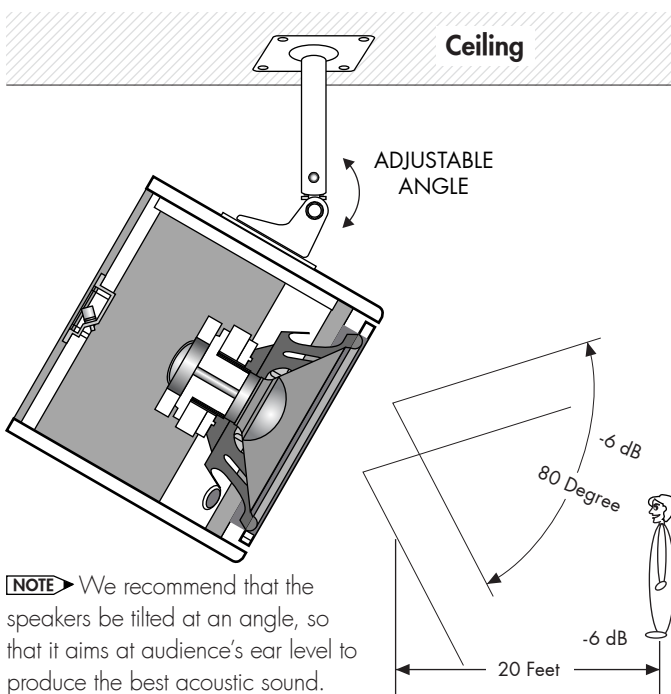
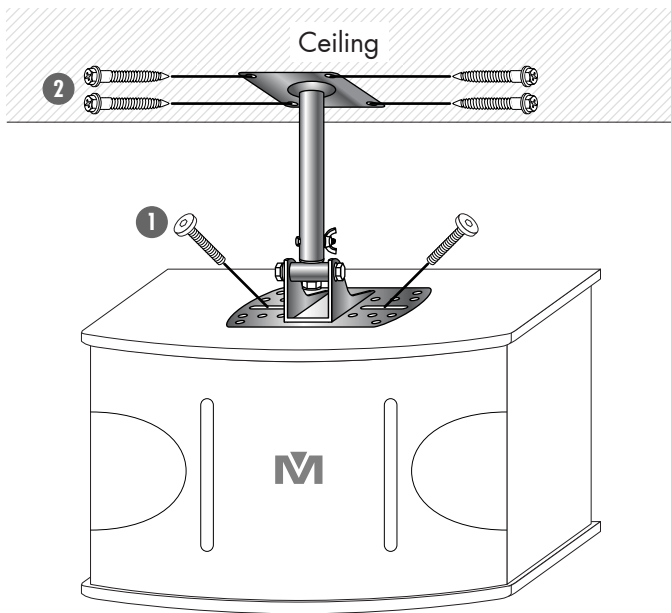

NOTE We recommend that the speakers be tilted at an angle, so that it aims at audience's ear level to produce the best acoustic sound.

Adjusting the Ceiling Mount (NB-901)

Precise Angle

The Ceiling Mount allows swing adjustment, slightly loosen a screw to make an adjustment, then re-tighten. Once you have set up the right position, then you can use the screw to tight it up.

Extended Ceiling Mount

The length of the arm for the wall/ceiling mount is 7.5 inches without any extension. With full extension, the maximum length of the arm is 12.5 inches. Since there are 5 drops on the extension and each drop is 1 inch.

Part Number: NB-901 (Optional) for ceiling mount.

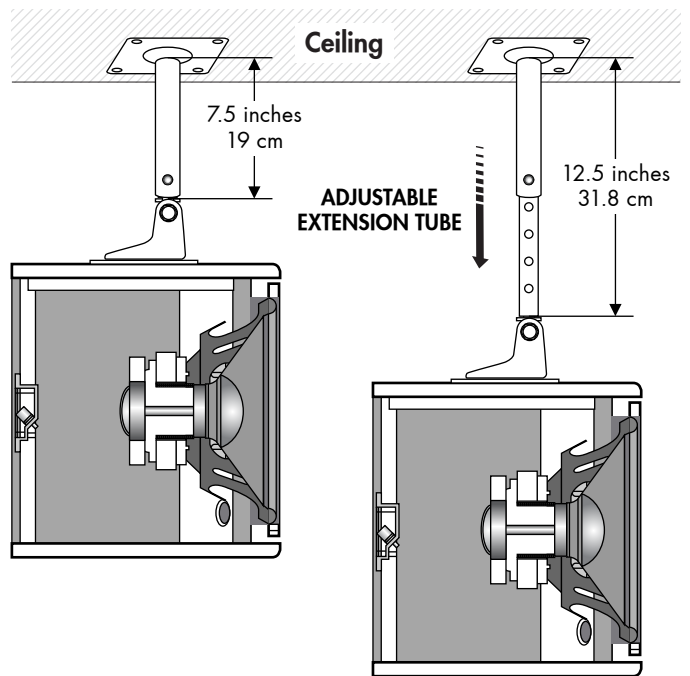

Dimensions: Wall Mount (NB-901)

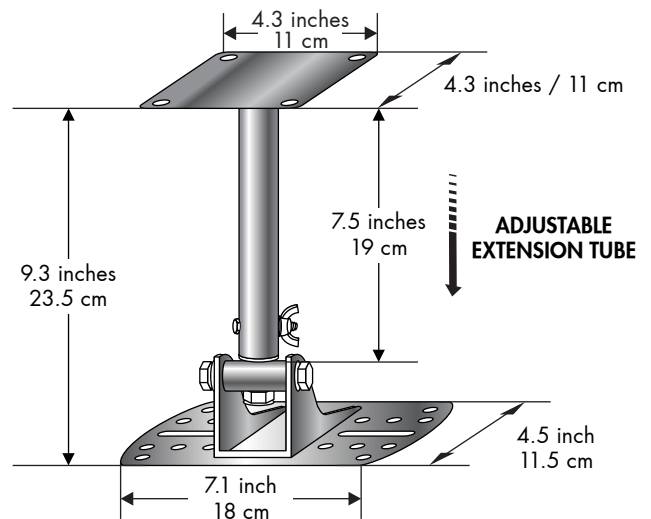

2. MOUNTING THE SPEAKER TO THE WALL

STEP 1: Place the wall mount panel on the top of the speaker cabinet and use two screws to fasten it.

STEP 2: Then, use four screws to hold the speaker firmly into the wall.

NOTE The structure of the ceiling must be strong enough to hold at least 50 pounds.

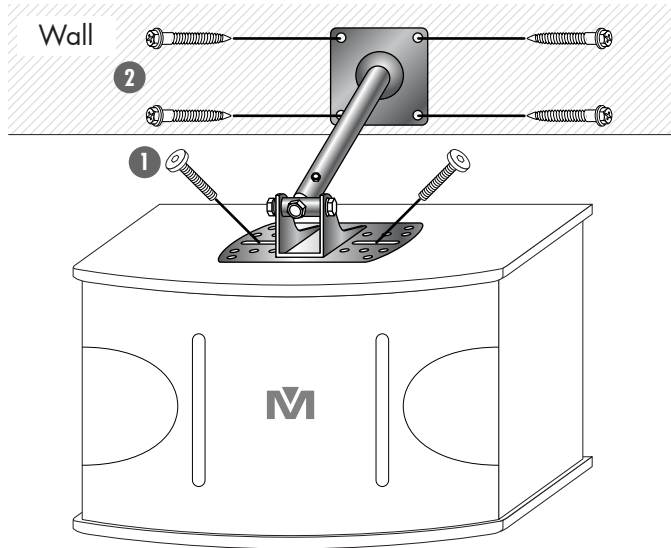

Mounting to Solid Wood or Wood Studs

In North America, most of the houses have 2"x4" wood studs inside the panel walls. You may use stud finder to locate the wood studs. Then, you can drive the screw into the wood stud to mount the speaker bracket and hold it firmly.

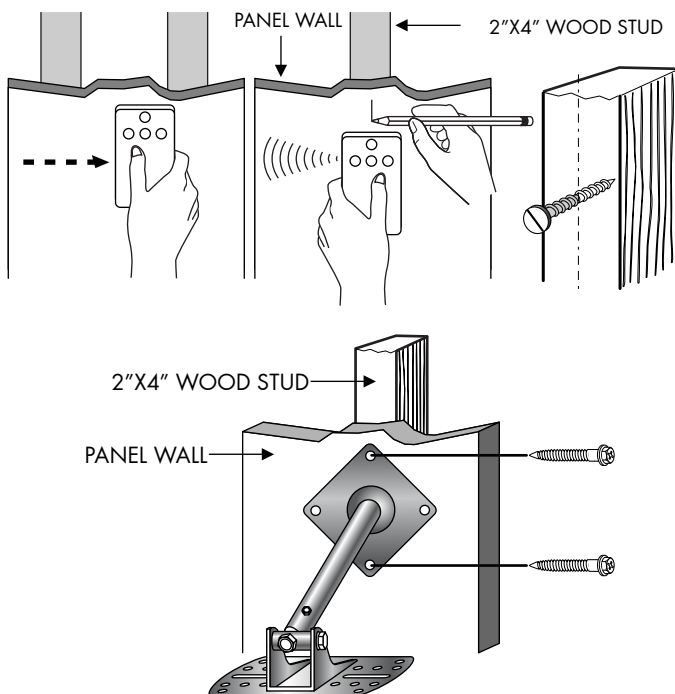

Adjusting the Wall Mount (NB-901)

Precise Angle

The Wall Mount allows swing adjustment, slightly loosen a screw to make an adjustment, then re-tighten. Once you have set up the right position, then you can use the screw to tight it up.

Extended Wall Mount

The length of the arm for the wall/ceiling mount is 7.5 inches without any extension. With full extension, the maximum length of the arm is 12.5 inches. Since there are 5 drops on the extension and each drop is 1 inch.

Part Number: NB-901 (Optional) for wall mount.

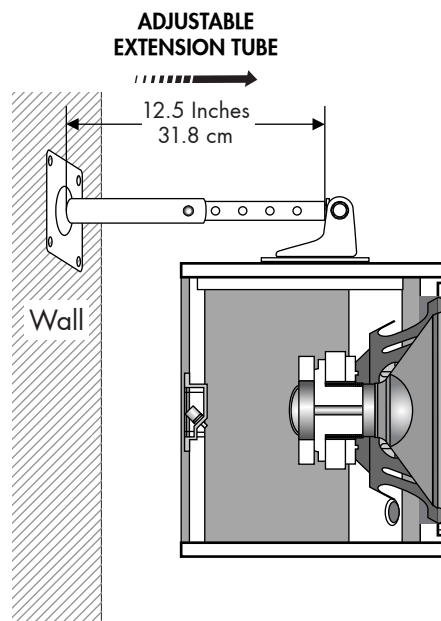
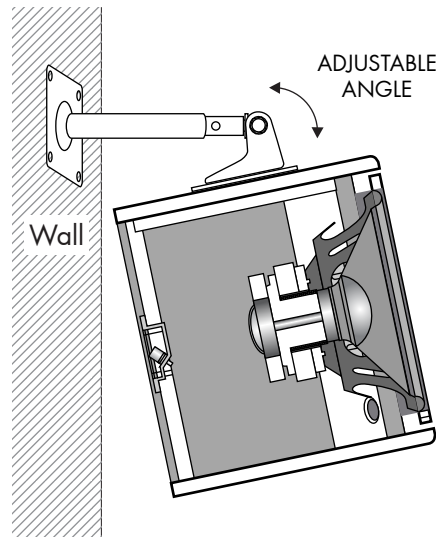

3. PLACING THE SPEAKER ON THE FLOOR TO MONITOR SINGING

This speaker can be placed on the floor to perform the vocal monitoring function for live singing experience. It can also be used for business conference, coffee shop and church, etc.

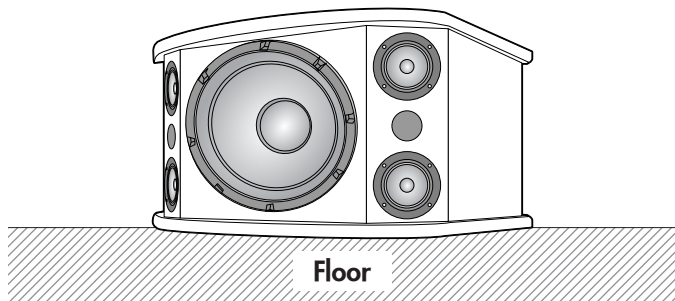

4. PLACING THE SPEAKERS ON THE PORTABLE STAND

The speakers can be mounted on to the optional portable stand (see figure below). Make sure that the mounting system (hardware, stand, etc.) is capable of supporting four times the weight (approximately 25 lbs per speaker) of the speakers.

Part Number: AMS001B (Optional).

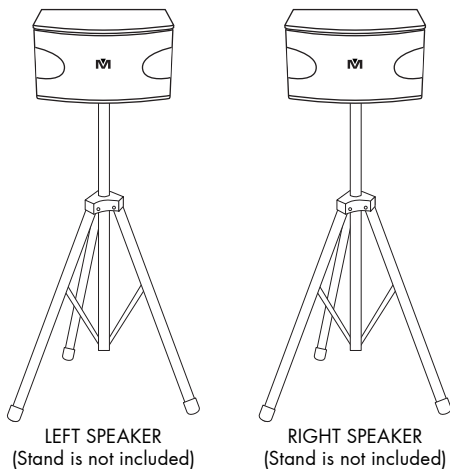

NOTE Please do not stack two-pieces of speakers onto the adjustable speaker stand. If you need two more speakers to increase the output volume, we recommend you to use a high power speaker instead of stacking two-pieces of speaker on the adjustable speaker stand for safety purpose. You may also contact us at www.bettermusicbuilder.com for professional advice.

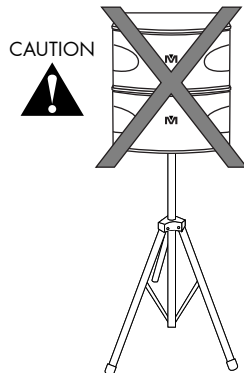

Speaker Stand External Adapter Mount

Dimensions:

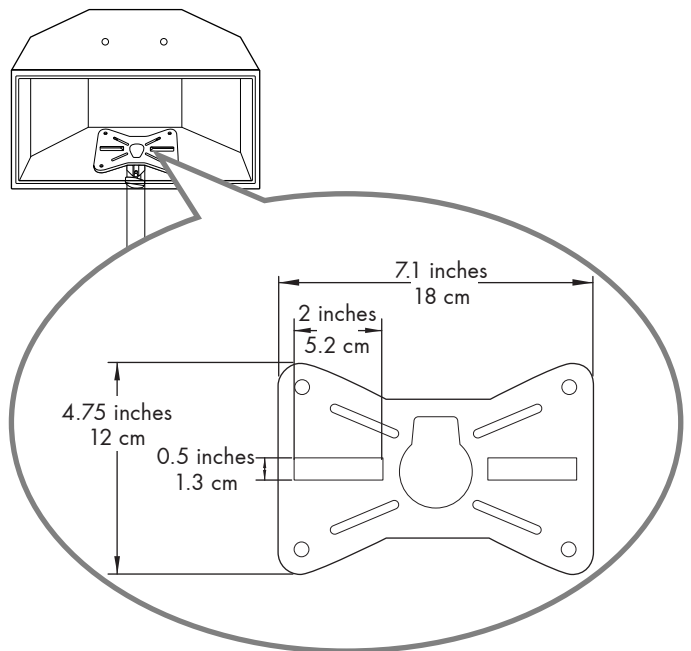

Installing Speaker Stand External Adapter Mount

When installing the speaker to the external adapter mount, please use the screws already on the speaker. If the head of the screw is too small for the rectangular gap on the external adapter mount, place a flat washer in between the screw and the gap.

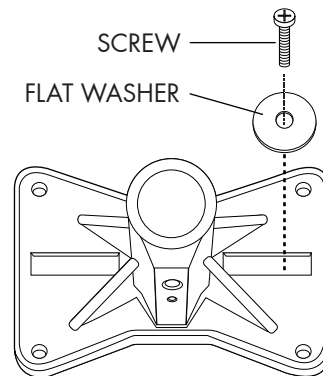

To stabilize the hold on external adapter mount to the pole, apply the tightening knob to the external adapter mount.

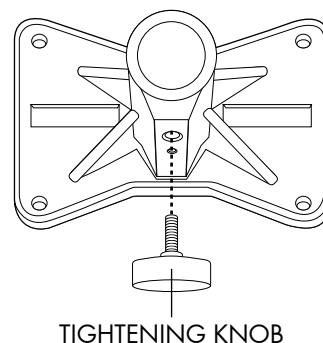

RECOMMENDED TOOLS

The recommended tools in this page are not included in the package. You may purchase the recommended tools and other accessories from a hardware store.

We at Better Music Builder always provide our customers with useful information on audio equipment installation to make your installation safe and easy.

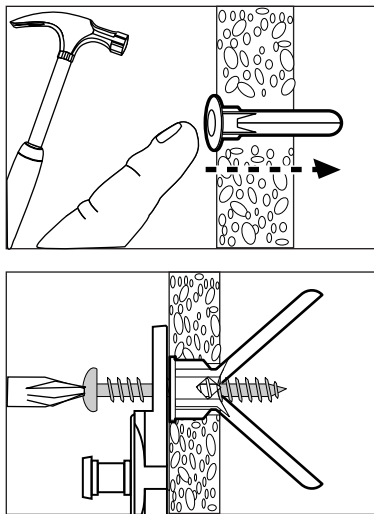

Pencil

NOTE Before installation, please use a template to mark the location for drilling.

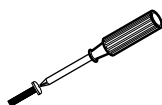

Phillips Head Screw Driver



Electric Drill

NOTE Please adjust the speed of the electric drill, or it may damage the screw. We recommend using a screw gun or a variable speed drill.

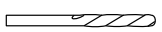

Drill Bits: 1/8" drill bit for drywall

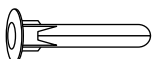

Plastic Anchor



8-32x1/2" Phillips pan head machine screw

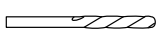

3/32" Drill Bit

NUTS AND SCREWS

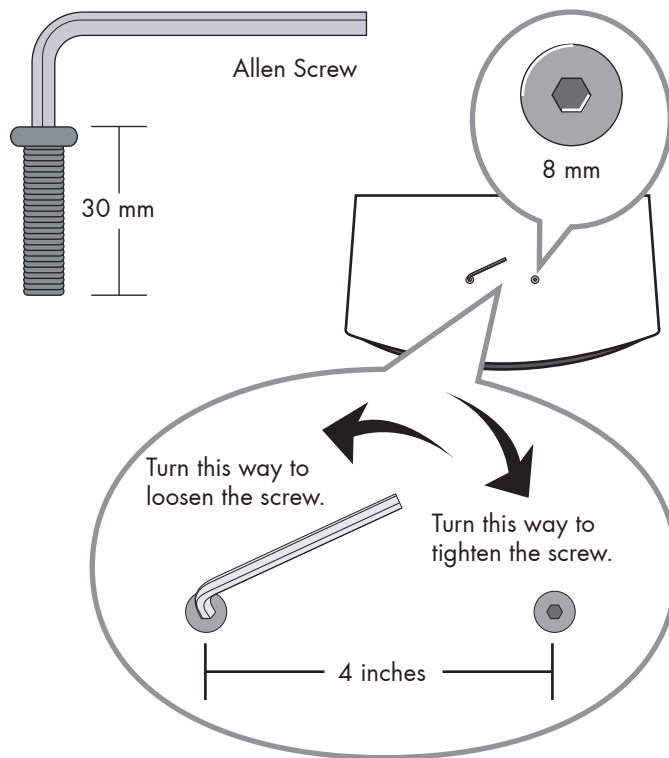

LOGO ROTATION

To install the speaker on a stand, you may rotate the speaker front grill 180 degrees, so that the logo is upright.

NOTE Please wear gloves when rotating grill as it has sharp edges!

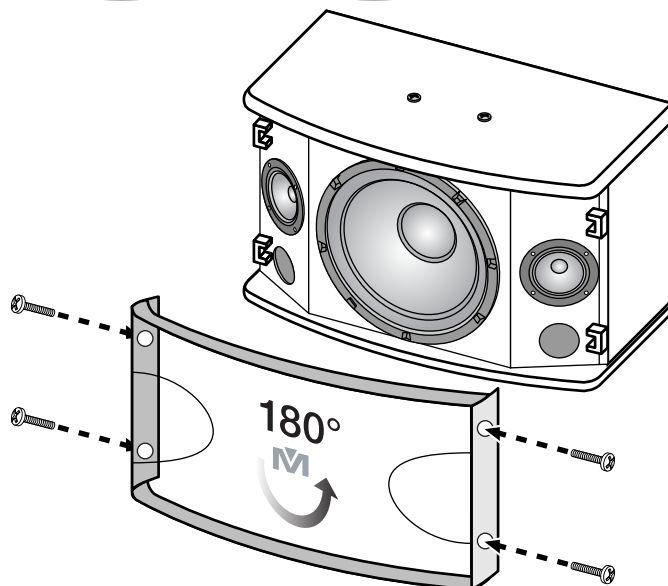
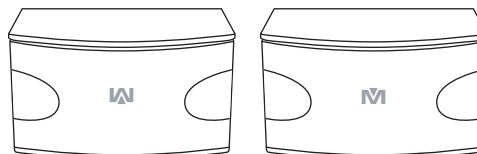

CS-600 G3 (10-inch Woofer)

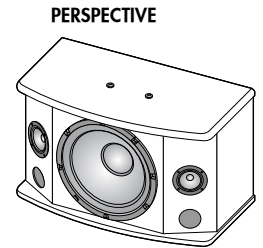
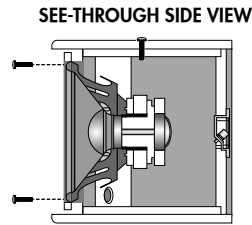
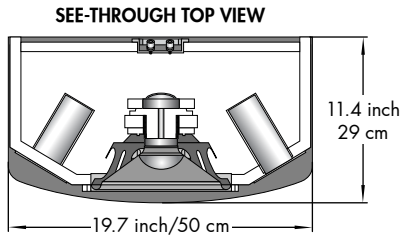
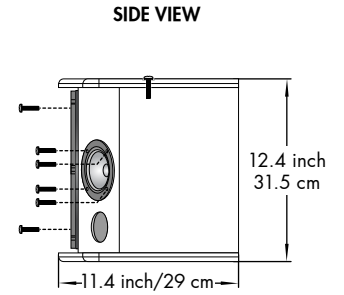
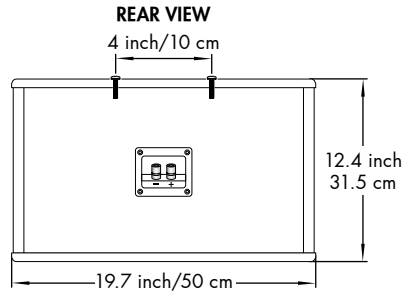
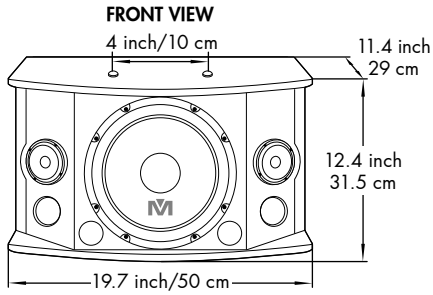

CS-612 G3 (12-inch Woofer)

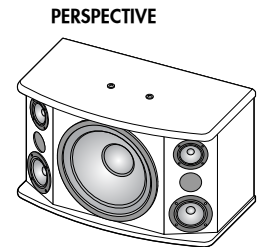
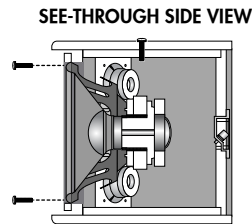
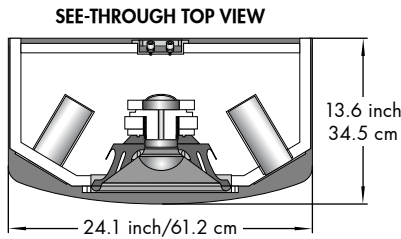
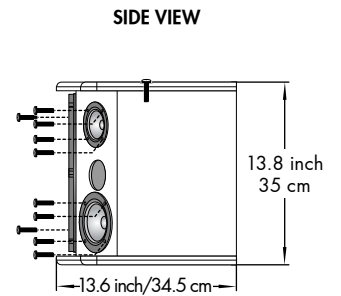
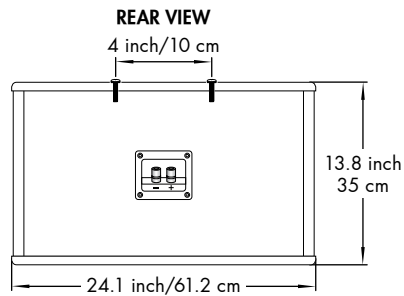
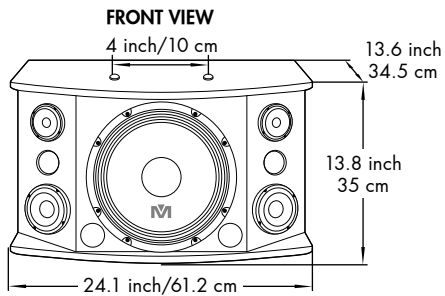

CS-812 G3 (12-inch Woofer)

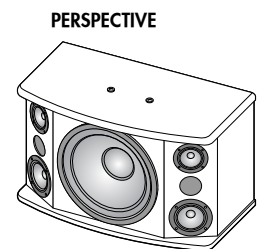
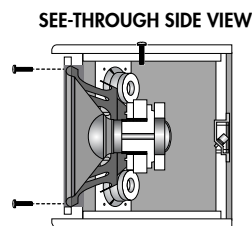
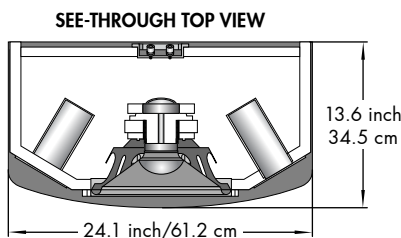
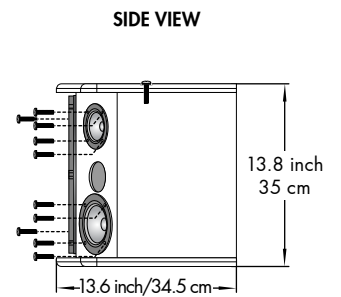
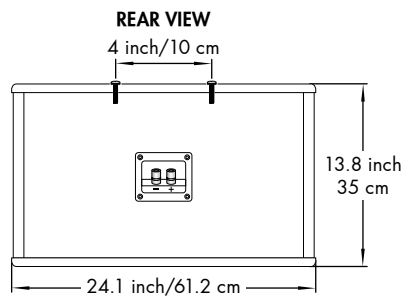
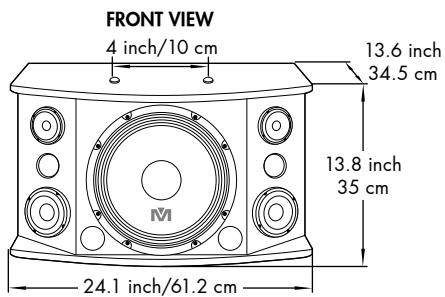



PHYSICAL DIMENSIONS

	3-WAY FULL RANGE LOUDSPEAKER		
MODEL	CS-600 G3	CS-612 G3	CS-812 G3
NET WEIGHT	23.8 lbs / 10.8 kg (each)	36 lbs / 16.3 kg (each)	38 lbs / 17.2 kg (each)
SHIPPING WEIGHT	54 lbs / 24.5 kg (pair)	50 lbs / 22.7 kg (each)	50 lbs / 22.7 kg (each)
DIMENSIONS (WXHXD)	19.7 x 12.4 x 11.4 in 50 x 31.5 x 29 cm (each)	24.1 x 13.8 x 13.6 in 61.2 x 35 x 34.5 cm (each)	24.1 x 13.8 x 13.6 in 61.2 x 35 x 34.5 cm (each)
PACKING DIMENSIONS (WXHXD)	27 x 24 x 15.7 in 68.5 x 61 x 40 cm (pair)	17.7 x 28.7 x 16.9 in 45 x 73 x 43 cm (each)	15.4 x 27.2 x 16.1 in 39 x 69.1 x 40.8 cm (each)

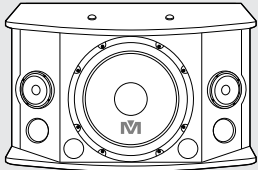
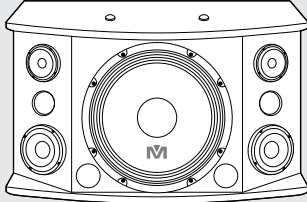
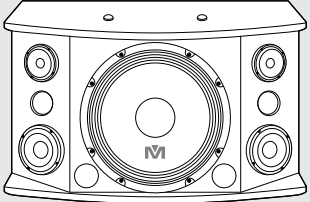

SPECIFICATIONS

	3-WAY FULL RANGE LOUDSPEAKER		
MODEL	 CS-600 G3	 CS-612 G3	 CS-812 G3
TYPE	Front	Front	Front
MAX. POWER HANDLING	450 Watts	600 Watts	600 Watts
CABINET TYPE	Piano Wood	PVC, Plywood	Piano Wood
SUPPORTED FIXTURE	Ceiling, Wall Mount, Floor Stand	Ceiling, Wall Mount, Floor Stand	Ceiling, Wall Mount, Floor Stand
WOOFER [Low Frequency]	10" (1 unit)	12" (1 unit)	12" (1 unit)
TWEETER [Middle Frequency]	3" (1 units)	4" (2 units)	4" (2 units)
TWEETER [High Frequency]	3" (1 units)	3" (2 units)	3" (2 units)
RATED IMPEDANCE	8 ohms	8 ohms	8 ohms
FREQUENCY RESPONSE	40Hz ~ 18kHz (± 3 dB)	25Hz ~ 18kHz (± 3 dB)	25Hz ~ 18kHz (± 3 dB)
SENSITIVITY	91 dB/1W/1M	93 dB/1W/1M	93 dB/1W/1M
CROSSOVER FREQUENCY	LF: 300Hz HF: 6.3kHz	LF: 300Hz HF: 6.3kHz	LF: 300Hz HF: 6.3kHz
HIGHLIGHTED FEATURES	3-Ch Karaoke / Piano Wood	3-Ch & 5-Ch Karaoke	3-Ch & 5-Ch Karaoke / Piano Wood



TROUBLESHOOTING

1. SYMPTOM: NO SOUNDS COMING OUT FROM THE SPEAKERS

Probable causes:

1. The A/C power of the speaker is turned off.
2. Wrong A/C power selection (i.e. 110V~ 220V).

Remedy:

- A. Turn on the A/C power of the speaker.
- B. Make sure the receiver or amplifier is on and the source is playing.
- C. Check all wires and connections between receivers, amplifiers and speakers. Make sure all wires are connected, none of the speaker wires are frayed, cut or punctured, and that no wires are touching each other.
- D. Review proper operation of your receiver or amplifier.
- E. Choose the right A/C power.

2. SYMPTOM: NO SOUNDS COMING OUT FROM ONLY ONE SPEAKER

Probable cause:

The A/C power of the speaker is turned off.

Remedy:

- A. Check the "Balance" control on your receiver or amplifier.
- B. Check all wires and connections between receiver, amplifier and speaker. Make sure all wires are connected, none of the speaker wires are frayed, cut or punctured, and that no wires are touching each other.
- C. In Dolby® Digital or DTS® mode, make sure that the receiver or processor is configured so that the speaker in question is enabled.
- D. Turn off all electronics and switch the speaker in question with another speaker that is working correctly. Turn everything back on, and determine whether the problem is in the same place: i.e., the speaker that was working previously now has no sound and the speaker that was not working now sounds fine. If the problem is in the same place, the source of the problem is most likely with your receiver or amplifier, and you should consult the owner's manual for further information. If the problem is with the speaker, consult your dealer for further assistance, or visit our web site for technical support.

3. SYMPTOM: NOISES FROM THE SPEAKER.

Probable cause:

The A/C power cord of the speaker is not grounded.

Remedy:

Change a new magnet cord of the A/C power cord.

4. SYMPTOM: MICROPHONE VOLUME IS TOO LOW.

Probable causes:

- A. The microphone is poorly connected to the speaker.
- B. The volume on the speaker is too low.

Remedy:

- A. Check the connection between the microphone and the speaker. Make sure that they are connected properly. Condense microphone doesn't work with the speaker. You may need to change to a dynamic vocal microphone.
- B. Turn the volume to an appropriate level. If the volume is still not high enough, you may need to upgrade your existing audio system to a system with much higher output.

5. SYMPTOM: CRACKING NOISES FROM THE SPEAKER.

Probable cause:

The tweeter may be burned out.

Remedy:

Replace with a new tweeter.

Note: we recommend hiring a professional to change a tweeter in order to do it properly.

6. SYMPTOM: SOUNDS LIKE DAZZ, DAZZ, DAZZ COMING FROM THE SPEAKER.

Probable cause:

The speaker cable (with small gauges) is over 100 feet.

Remedy:

Change to a higher quality cable preferably 12 and 14 gauges.



FINAL WORDS TO USER

7. SYMPTOM: TOO MUCH MICROPHONE FEEDBACK FROM THE SPEAKER.

Probable cause:

Incorrect tremble and bass adjustments on the speaker.

Remedy:

Adjust the tremble and bass to an appropriate level to avoid microphone feedback.

8. SYMPTOM: NO SOUND FROM THE MAIN SPEAKERS

Probable cause:

Speaker connectors are not connected properly.

Remedy:

Please make sure that the speaker connectors are locked tight. Please also note that there are two groups of speaker connectors (i.e. Group 1 +1, -1, Group 2 +2, -2). Make sure that your speakers have the multifunction that enables the connection to Group 2 for different signal inputs. The basic connection is on Group 1 (+1, -1).

9. SYMPTOM: SOMETIMES THE SPEAKERS HAVE NO SOUND.

Probable cause:

When the master volume reaches the maximum level, the speaker automatically shuts down because this speaker has a built-in auto circuit to protect itself when the master volume becomes too high.

Remedy:

Change to a higher power amplifier to work with the speakers. Please make sure the output power of the amplifier can match that of the speakers. Another option is to add more speakers or subwoofers for higher output as below.

1. Add one more loudspeaker.
2. Add one more powered subwoofer.

We highly recommend hiring an audio professional for advise on the right engineering for the amplifier and speakers.

The engineering team of Better Music Builder has many years of experience in audio equipment design. The team constantly develops new audio technologies, designs innovative audio and karaoke equipment to suit your specific needs and provides you great ideas for home entertainment.

Our engineering team also designs audio equipments for commercial use by restaurants, coffee shops, churches, and school auditoriums, etc. If the commercial area for audio equipment installation exceeds 2,000 square feet, we highly recommend hiring audio professionals to handle the installation to avoid damaging the equipment with improper installation and safety protection purposes.

We also provide educational and technical information on audio equipments and technologies. For example, we provide free installation diagrams to make it easier to connect the system. In addition, to get best connections for the sharpest image and sound quality, we provide hot tip for choosing high quality A/V cables. Free information on audio equipments and technologies is available for download on our website, www.BetterMusicBuilder.com.

Please do not remove the "Yellow Label" in the rear of the machine; otherwise, the warranty will be void automatically. We design it to protect your own safety. If repair and maintenance service is needed, please contact us directly or hire a professional technician. To learn more about the technical aspects, visit our website www.BetterMusicBuilder.com and download relevant information for review.



Before hooking up the system, turn off the AC powers on all machines including audio/video equipment and TV. Otherwise, it may damage the equipment, especially on the HDTV in which a spot might appeared on the TV screen. After hooking up the system, double check the audio/video connections to ensure that they are connected correctly.

NOTE Sometimes, loose or poor cable quality would affect the microphone effects, picture quality, or even cause the machine to shut down suddenly.

Again, we must thank you for choosing a Better Music Builder product. We hope you can make the best use of the machine and enjoy it for years to come. If you have any questions regarding our product, please feel free to contact us at www.BetterMusicBuilder.com.



WARRANTY

ONE-YEAR LIMITED WARRANTY FOR HOME USE EQUIPMENT

Our one-year warranty covers both parts and labors. The warranty becomes effective from the date of your purchase for one year.

Our warranty only covers defects due to product defectiveness with free of defects in materials or workmanship. However, our warranty does not cover defects due to normal wears, damage in transit, improper use, abuse or failure to follow the proper instructions for maintenance. This warranty is void in the event of unauthorized repairs, alternations, modifications and removing of the product label.

Please also note that our warranty does not cover any shipping cost for the return of defective products to us for inspection, repair and maintenance. Our warranty for Better Music Builder products can only be executed in North America.

90-DAY LIMITED WARRANTY FOR PUBLIC AND COMMERCIAL USE EQUIPMENT

Our 90-day warranty applies to speakers, amplifiers, mixers and microphones for both public and commercial use such as restaurant, coffee shop, KTV nightclub, church and school, etc. It covers both parts and labors. The warranty becomes effective from the date of your purchase for 90 days.

Our warranty only covers defects due to product defectiveness with free of defects in materials or workmanship. However, our warranty does not cover defects due to normal wears, damage in transit, improper use, abuse or failure to follow the proper instructions for maintenance. This warranty is void in the event of unauthorized repairs, alternations, modifications and removing of the product label.

Please also note that our warranty does not cover any shipping cost for the return of defective products to us for inspection, repair and maintenance. Our warranty for Better Music Builder products can only be executed in North America.

ADDITIONAL NOTES:

1. Limited warranty for home use equipment is only valid in North America.
2. Limited warranty is valid only if you purchase our products from our authorized dealers (including both regular retailers and online retailers) in North America. If you choose to purchase our products from an authorized dealer, we will not provide any limited product warranty for you. To protect your limited product warranty, please purchase our products from one of our authorized dealers in North America near you.
3. Limited warranty is automatically void if the yellow label stating "No Warranty After Opening" is removed from the product.

TO REGISTER YOUR WARRANTY

Please fill out the warranty card that came with your unit, download or submit online warranty form. However, we need the invoice for your purchase in order to process this warranty. You may also register your warranty online. Please visit our website at www.bettermusicbuilder.com.



AGENCY REGULATORY NOTICES

Federal Communications Commission Notice

These limits are designed to provide reasonable protection against harmful interference in a residential installation. This equipment generates, uses, and can radiate radio frequency energy and, if not installed and used in accordance with the instructions, may cause harmful interference to radio communications. However, there is no guarantee that interference will not occur in a particular installation. If this equipment does cause harmful interference to radio or television reception, which can be determined by turning the equipment off and on, the user is encouraged to try to correct the interference by one or more of the following measures:

- Reorient or relocate the receiving antenna.
- Increase the separation between the equipment and the receiver.
- Connect the equipment into an outlet on a circuit different from that to which the receiver is connected.
- Consult the dealer or an experienced radio or television technician for help.

Modifications

The FCC requires the user to be notified that any changes or modifications made to this device that are not approved may void the user's authority to operate the equipment.

Cables

Connections to this device must be made with shielded cables with metallic RFI/EMI connector hoods to maintain compliance with FCC rules and regulations.

Materials Disposal

Disposal of this material can be regulated because of environmental considerations. For disposal or recycling information, contact your local authorities or the Electronic Industries Alliance (EIA) (<http://www.eiae.org>).

Disposal Of Waste Equipment By Users In Private Households In The European Union

This symbol on the product or on its packaging indicates that this product must not be disposed of with your other household waste. Instead, it is your responsibility to dispose of your waste equipment by handing it over to a designated collection point for the recycling of waste electrical and electronic equipment. The separate collection and recycling of

your waste equipment at the time of disposal will help to conserve natural resources and ensure that it is recycled in a manner that protects human health and the environment. For more information about where you can drop off your waste equipment for recycling, please contact your local city office, your household waste disposal service or the shop where you purchased the product.

Japanese Notice

この装置は、情報処理装置等電波障害自主規制協議会（VCCI）の基準に基づくクラスB情報技術装置です。この装置は、家庭環境で使用することを目的としていますが、この装置がラジオやテレビジョン受信機に近接して使用されると、受信障害を引き起こすことがあります。
取扱説明書に従って正しい取り扱いをして下さい。

Japanese Power Cord Notice

製品には、同梱された電源コードをお使い下さい。
同梱された電源コードは、他の製品では使用出来ません。

Japanese Material Content Declaration

A Japanese regulatory requirement, defined by Specification JIS-C-0950, 2005, mandates that manufacturers provide Material Content Declarations for certain categories of electronic products offered for sale after July 1, 2006.

Korean Notice

B급 기기 (가정용 방송통신기기)	이 기기는 가정용(B급)으로 전자파적합등록을 한 기기로서 주로 가정에서 사용하는 것을 목적으로 하며, 모든 지역에서 사용할 수 있습니다.
-----------------------	--

Recycling Program

The terms and availability of these programs vary by geography because of differences in regulatory requirements and local customer demand.

因为在当地的监管要求和客户的需求，这些条件和程序的情况不同。



NEW PRODUCTS (MUSIC SOURCE)

WHAT IS A HARD DRIVE?

Today, we have all these data for music and karaoke but they are in different formats like CD-G, VCD, DVD, Youtube videos, Blu-ray, etc. While there is no simple way to build a machine that can play all these formats, why not just take all the information and load the audios, videos, and pictures inside the machine. That's where our new VOD product line comes in.

With the advances of current hard drives, our VOD product

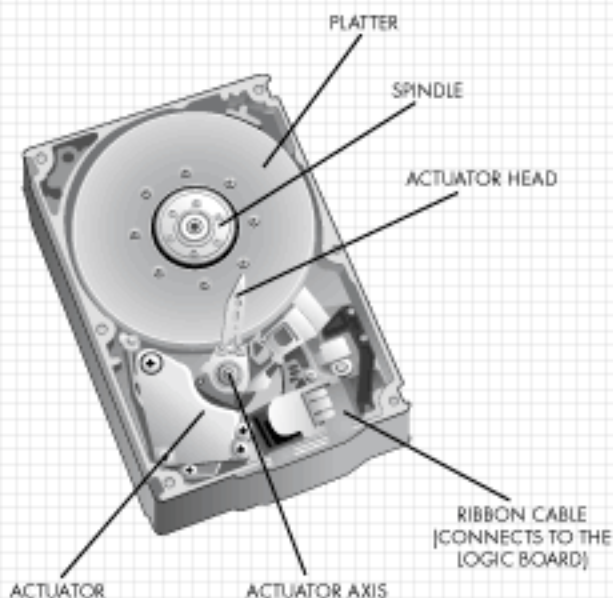

comes with up to 3 TB of hard drive. What that means is you can store all your pictures, movies, music into our VOD system and still have room to spare.

The major benefit is storing everything in one place. No longer do you need to keep wondering where you put those old vacation photos or that song you used to like. In the

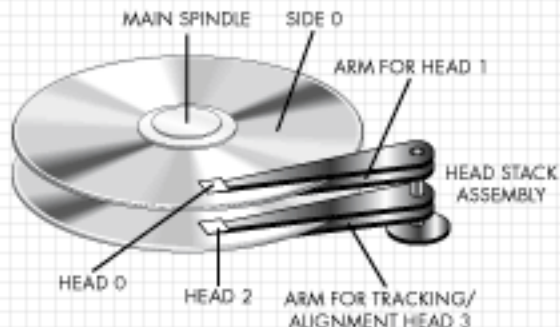

following pages we will show you how to put everything in your hard drive so you can have the convenience of finding everything in one place.

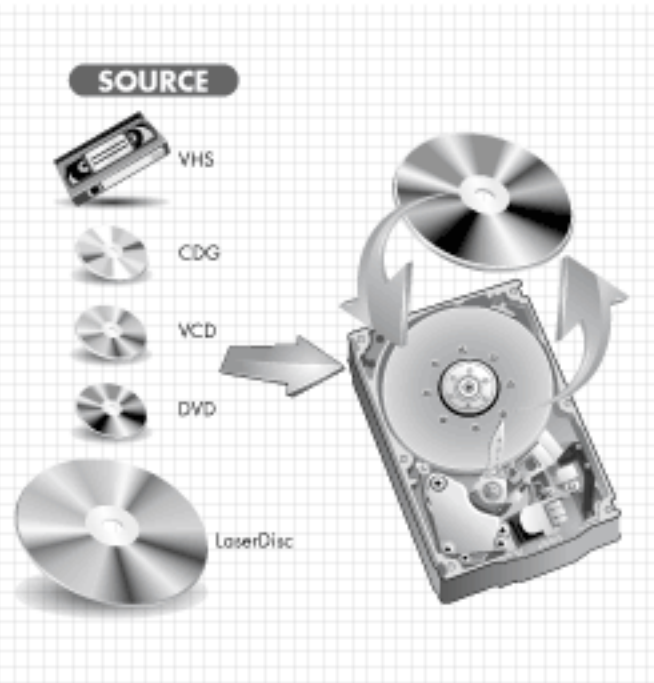

WHAT DOES 3 TB MEAN?

The new products VOD-600, VOD-900, and Hitbox PC all comes with up to 3 TB of hard drive space with expandable ports. But how much is 3 TB actually?

It means 4,000 CDs



or 600 DVDs



or 120 Blu-ray discs

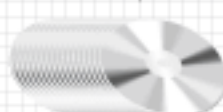

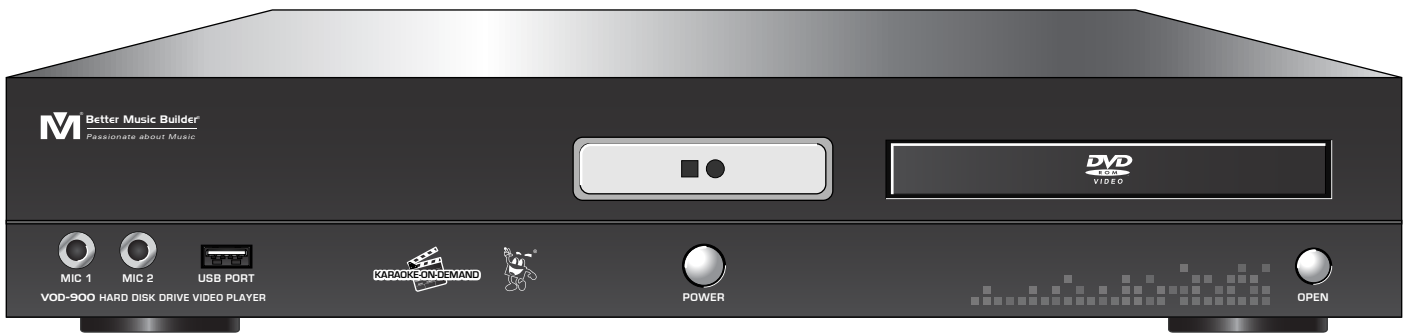

HARD DISK DRIVE VIDEO PLAYER VOD-900

The VOD-900 will be the first multimedia player produced by Better Music Builder. This player comes with high definition capabilities and has two hard drive ports for your data. It comes with pre-installed software to manage your all your audio and video. Please understand copyright laws in your region regarding the music data that are being used.

DUAL HARD-DRIVE

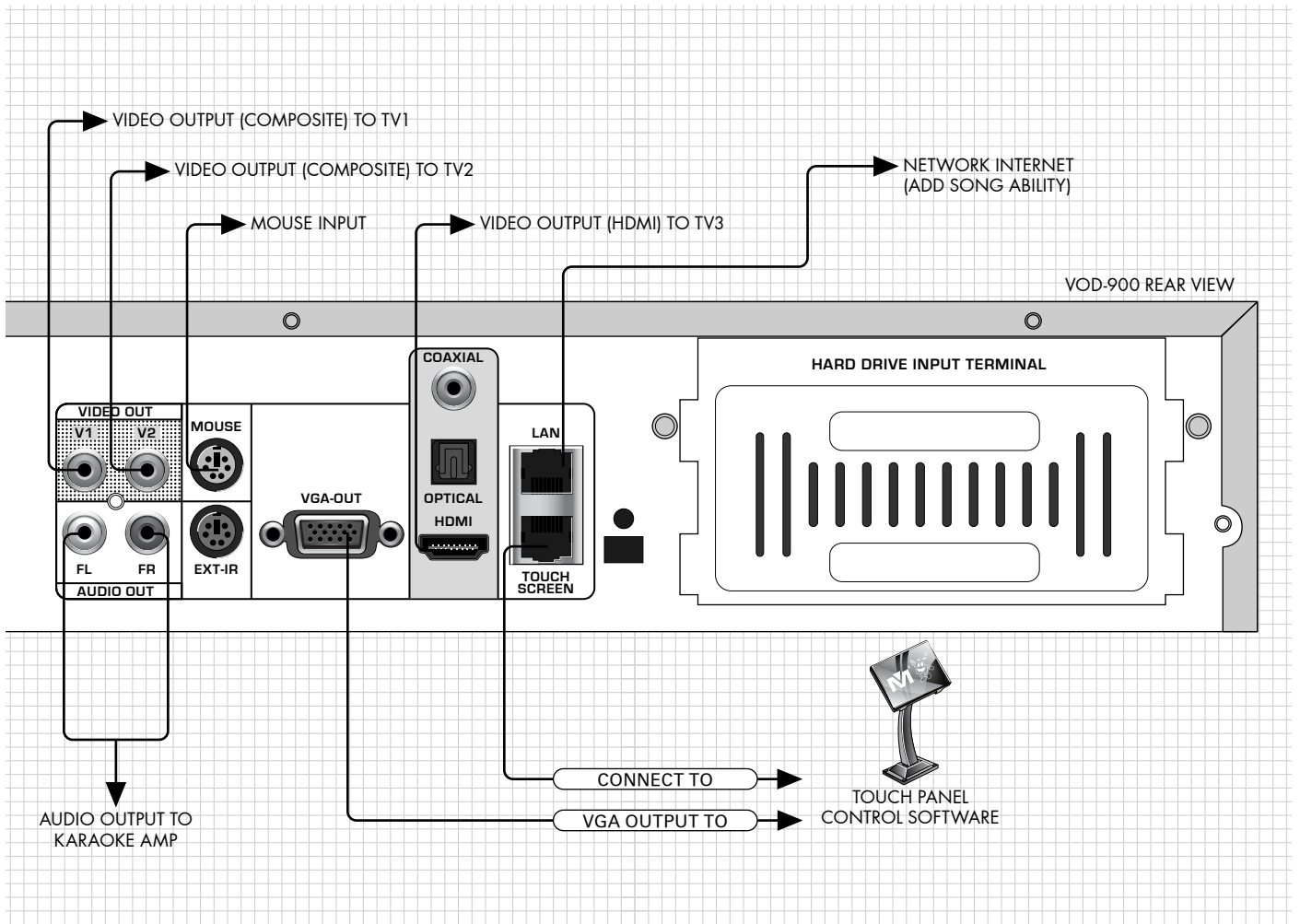
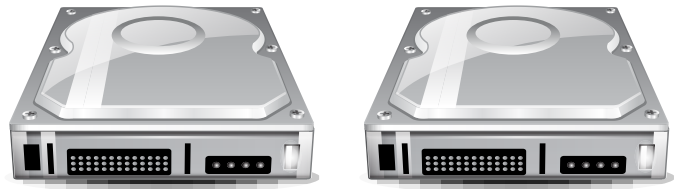



CONTACT INFORMATION

MAILING ADDRESS



BETTER MUSIC BUILDER
29300 Kohoutek Way #150
Union City, CA 94587
U.S.A.

TELEPHONE NUMBERS



USA Region
USA Toll Free: 1-800-318-2218
Sales & Marketing: 510-477-9955
Customer Service: 510-477-9955

FAX NUMBERS



USA Region
Sales & Marketing: 510-477-9922
Customer Service: 510-477-9922

WORLD WIDE WEB



E-mail: sales@bettermusicbuilder.com
Website: www.bettermusicbuilder.com

MAINTENANCE

With proper maintenance and regular service, it would maintain the machine quality and prolong its life. We recommend you to print the following information clearly for future reference on maintenance and warranty.

MODEL# _____ DATE PURCHASED (MM/DD/YYYY) _____

DEALER NAME _____ CITY _____ ST./PROV. _____ ZIP/P.C. _____

DEALER WEBSITE <http://www.> _____ INVOICE # _____

DEALER PHONE # _____ DEALER E-MAIL _____

Better Music Builder®.com



Passionate about Music

Thank you for purchasing this unit. To make full and effective use of this unit, please read this Owner's Manual carefully before operating it. Please retain this manual for future reference.

